



FPL®

Electric Service Standards

for Overhead, Underground and
Residential Subdivision Areas

Sept 2011 Online Edition

Distribution Construction Processes

SECTION

Foreword

Summary of 2009 Revisions

Table of Contents

- I. Definitions**
- II. General**
- III. Service Provisions**
- IV. Service and Meter Connections**
- V. Requirements for Transformers Situated on Customer Property**
- VI. Metering Equipment**
- VII. Approved Metering Equipment Enclosure List**
- VIII. Grounding**
- IX. Motors, Controllers and Air Conditioners**
- X. Electrical Disturbances**
- XI. Radio, Television and Miscellaneous Antennas**
- XII. Street and Outdoor Security Lighting**
- XIII. Safety**

JUST A REMINDER!

FLORIDA STATUTE 812.14 STATES "IT IS UNLAWFUL TO WILLFULLY ALTER, TAMPER WITH, INJURE, OR KNOWINGLY SUFFER TO BE INJURED ANY METER, METER SEAL, PIPE CONDUIT, WIRE, LINE, CABLE, TRANSFORMER... OR TO ALTER THE INDEX OR BREAK THE SEAL OF ANY METER..."

PLEASE KEEP SAFETY FIRST -- CALL YOUR LOCAL FPL CONSTRUCTION OFFICE FOR AN APPOINTMENT TO DISCONNECT THE SERVICE AND REMOVE THE SEAL/METER. REFER TO SECTION III-I OF THESE ELECTRIC SERVICE STANDARDS REGARDING THE EXCEPTION ALLOWED BY FPL.

FOREWORD

FPL, in cooperation with customers and their agents, wishes to provide adequate electric service in an expeditious manner.

This publication, FPL's Electric Service Standards (ESS), is intended to furnish information often required by customers and their agents (builders, architects, engineers, electricians, etc.) to receive FPL's electric service. The ESS is subject to and subordinate in all respects to FPL's Tariff, as amended from time to time and approved by the Florida Public Service Commission, the Florida Administrative Code as it pertains to publicly held utilities, and to the provisions of the current edition of the National Electrical Safety Code.

This document is not intended to be all inclusive and is not a substitute for direct communication between the Customer and FPL. This direct communication is essential to mutually understanding service needs and requirements, and the ability of FPL to provide prompt and adequate electric service.

The personal pronouns "he", "him", "his", etc., when used in the text, are generic and not intended to specify a particular sex.

FPL's ESS is revised periodically due to ongoing changes in engineering and construction practices. Consequently, some of the provisions contained herein may be obsolete. **It is essential that the Customer or his agent contact FPL's representative to ensure he has the latest issue of FPL's Electric Service Standards, in addition to any new or other pertinent information that may not be published. The latest version and other information can be found by visiting us on the web at www.FPL.com/builder**

CHANGE OF MAILING ADDRESS

To all those builders, developers, architects, engineers, electrical contractors, electrical inspectors, etc. on FPL's current mailing list, FPL will distribute this publication as it becomes revised in the future. Should you desire a copy of either this or future issues, or wish to notify FPL regarding a change of mailing address, please mail your request to:

FPL
ESS Administrator (DCP/GO)
P.O. Box 029100
Miami, FL 33102-9100

And, please provide the following information:

EXISTING ADDRESS INFORMATION

(If already on list)

Name:
Attention: (if applicable):
Street Address or P.O. Box:
City, State, and Zip:
Phone Number:

NEW/REVISED ADDRESS INFORMATION

Name:
Attention: (if applicable):
Street Address or P.O. Box:
City, State, and Zip:
Phone Number:



Electric Service Standards

DATE
02-02-12

PREPARED BY

SUBJECT

SECTION: PAGE

**Delivery Assurance –
Design Support**

SUMMARY OF 2009 EDITION REVISIONS

REV: 1 of 1

FPL's Electric Service Standards have been revised for hardcopy and for online publication in May 2009. Should you have any questions, please contact your local FPL Construction office.

Section	Title	Revision	Date
IV.A.1	Service Equipment – General	Revised , Added requirement to identify (tag) customer service at source	May 2009
Fig IV-14	Identification of Customer Service	New , Details for tagging customer owned services	
VII	Approved Enclosure List	Revised , Updated Approved Enclosure List	
XIII	Safety	Revised , Notification of FPL Facilities	Jun 2009
II	General	Revised , Contact telephone numbers for Treasure Coast Area	Oct 2009
VI	Metering Equipment	Revised , Limited self-contained 480V, 2 wire service to 320 amps	Oct 2009
II	General	Revised , Changed reference for obsolete FPL form 1745	Nov 2009
III.L	2 wire, 480V service	Revised , Clarified to indicate that it applies to metered service	Jan 2010
VI.B	Metering Equipment	Revised , Clarified 480V, 2 wire service to indicate that it applies to metered service	Jan 2010
III.A	Standard Service	Revised , Added 240/480V, 3 wire service	Mar 2010
III.G	Temporary Service	Revised , Clarified that approved meter enclosures are required	Mar 2010
Fig IV-1 and IV-2	Temporary Service	Revised , Clarified that approved meter enclosures are required	Mar 2010
Fig IV-8	Self-contained overhead service	Revised , Added 240/480V, 3 wire to wiring diagram	Mar 2010
IV.B.5	Installation of service entrance	Revised , Prohibited condulets and junction boxes	Apr 2010
Fig VI-9	Flood Elevation	Revised , Elevation is inspecting authority requirement, not FPL.	Apr 2010
IV.A.1	Service Equipment – General	Revised , Changed “should” to “shall” regarding accessibility of service equipment	Sep 2010
XII.C	Disconnect Devices for Customer-Owned Street/Outdoor Security Lighting	Revised , Customer required to supply relays for all group controlled street lights, OH or UG	Dec 2010
V.A	Transformer requirements	Revised , Corrected max wire size, added max # of 4” ducts for 1 phase regular style transformers	Jan 2011
Fig. VI-6a	Padmounted CT for Renewable Generation	New , Added specifications for primary metered installations for Renewable Generation interconnects	Mar 2011
IX.A	Motors, Controllers And Air Conditioners	Revised , Clarified maximum motor size by type of service	Apr 2011
IV, VI	Service Equip, Metering Equip	Revised , Changed manual bypass to lever bypass	Jun 2011
I, III.F	Definitions, Service Provisions	Revised , Clarified that Miami network is existing and no new networks are being constructed	Jul 2011
Fig IV-10	Service Equipment	New , Specifications for installing IBT	Jul 2011
VII	Approved Enclosure List	Revised , Updated Approved Enclosure List	Jul 2011
II	General	Revised , Updated service center contact info, updated Measuring Electric Consumption to match FAC 25-6.049 wording	Jul 2011
XIII	Safety	Revised , Replaced “Notification of Facilities” with updated version showing new OSHA clearances, updated “Safety 6” with new OSHA clearances	Jul 2011
XII	Street and Outdoor Lighting	Revised , Removed limit of one pole installed for the outdoor light	Sept 2011
VI-B	Metering Equipment	Revised , Restriction on use of multiple conductor lugs	Oct 2011
XIII	Safety	Revised , Replaced “Notification of Facilities” with updated version	Jan 2012
VIII	Grounding	Revised , To reflect clarifications to 2011 NEC Article 250.52	Jan 2012
IX	Motors, Controllers, and Air Conditioners	Revised , Added recommendation for “AURORA” protection	Feb 2012



FPL

Electric Service Standards

DATE

02-04-05

PREPARED BY

Distribution Construction Processes

SUBJECT

TABLE OF CONTENTS

SECTION: PAGE

TOC: 1 of 3

- I. **DEFINITIONS** 1
- II. **GENERAL** 1
 - A. Early Notification and Coordination 1
 - B. Application for Electric Service 1
 - C. Availability of Desired Type of Electric Service 2
 - D. Contributions by Customer 2
 - E. Rights of Way and Easements 2
 - F. Measuring (Metering) Electric Consumption 3
 - G. Conjunctive Billing or Totalized Metering as disallowed in FAC 25-6.102 4
 - H. Electrical Inspections and Connection of Service 4
 - I. Customer Responsibility for Safety and Adequacy of Wiring 4
 - J. Access to FPL Facilities 5
 - K. Load Balance 5
 - L. Customer Owned Generators 5
 - 1. Standby Generator 5
 - 2. Parallel Generation and Cogeneration 5
 - Caution** 6
 - M. Unauthorized Attachments 6
 - N. Continuity of Service 6
 - O. Conservation Programs 6
 - P. Contacting FPL 6
- III. **SERVICE PROVISIONS** 1
 - A. Standard Service 1
 - B. Point of Delivery 2
 - C. Extension of FPL's Electric Facilities 2
 - 1. General 2
 - 2. Overhead Extensions 2
 - 3. Underground Extensions 2
 - D. Residential Service (under 600v) 3
 - 1. Underground Service for New Residential Subdivisions (Less than 5 units per building) 3
 - 2. Underground Service from an Overhead System to New Residential Buildings (Less than 5 units per building) 4
 - 3. Replacement of Existing Overhead and Underground Residential Service Laterals 4
 - 4. Mobile Home and Recreational Vehicle (RV) Parks 4
 - 5. Multiple Occupancy Buildings (5 Units or more per building) 5
 - 6. High-Rise Residential Buildings 6
 - E. Commercial Service (under 600v) 6
 - Commercial Underground Service 6
 - a. Underground Service to Small Commercial Loads 7
 - b. Underground Service to Moderate Commercial Loads 7
 - c. Underground Service to Large Commercial Loads 7
 - d. Automatic Throwover Facilities to Large Commercial Loads 8
 - e. Loop Service to Large Commercial Loads 8
 - F. Underground Service Connections in the City of Miami Network Area 8
 - G. Temporary/Construction Service 9
 - 1. General 9
 - 2. Reduced Cost Alternatives 9
 - a. TOP 9
 - b. TUG 10
 - H. Unauthorized Connections & Disconnections 10
 - I. Change in Service Requirements (Service Changes) 10
 - J. Service to Special Equipment 11
 - K. Service to Boat Facilities 11



Electric Service Standards

DATE
02-04-05

PREPARED BY

SUBJECT

SECTION: PAGE

**Distribution Construction
Processes**

TABLE OF CONTENTS

TOC: 2 of 3

IV. SERVICE and METER CONNECTIONS	1
A. Service Equipment	1
1. General	1
2. Ampere Rating	1
a. Residential	1
b. Commercial	2
c. Service Equipment Rated Below 600 Volts	2
d. Service Equipment Rated Over 600 Volts	3
B. Overhead Service	3
1. Vertical Clearance to Ground	3
2. Clearance from Building Openings	3
3. Clearance from Swimming Pools	3
4. Anchorage for Overhead Service Drop Cable or Wires	3
5. Installation of Service Entrance	4
C. Illustrations	4
Temporary/Construction Service - from Overhead System (typical)	5
Temporary/Construction Service - from Underground System (typical)	6
FPL Electric Service and Meter Socket Requirements Form	7
Guide for Locating Point of Delivery on Outside of Building	8
Overhead Service - Minimum Vertical Clearances	9
Attachment of Service Drop at Buildings - to the Pipe Mast	10
Attachment of Service Drop at Buildings - to the Structure	11
Attachment of Service Drop at Buildings - to the Wood Eave	12
Outdoor Meter Installation - 1ph 120/240v 3 wire Overhead Service	13
Self Contained Meter Installation - Overhead Service	14
Lug-Type Meter Socket Installations	15
Configurations for Installing (2) Mains with FPL Underground Service	15
URD System Layout – Typical	16
FPL Buried Service Lateral – Meter Socket & Down Pipe Requirements	17
Residential Multiple Occupancy Buildings - Multiple Meter Center	18
Remote Meter Location, Typically used for Service to a Mobile Home	19
Pedestal Service - Customer Provided Meter Pedestal (typical)	20
Mobile Home Service - "Grouped" Service to Mobile Homes	21
V. REQUIREMENTS FOR TRANSFORMERS SITUATED ON CUSTOMER PROPERTY	1
A. Padmounted Transformer Requirements	1
B. Vault Requirements	3
C. "Stacked Vault" Requirements	5
VI. METERING EQUIPMENT	1
A. Equipment Furnished and Installed by FPL	1
B. Equipment Furnished, Installed, and Owned by the Customer	1
C. Metering Configurations & Approved Equipment	1
D. Location of Metering Equipment	2
1. Sequence in Service Entrance	2
2. Located Outdoors	2
3. Located Indoors	2
4. Flood Elevation Standards	2
E. Identification of Meters	3
F. Relocation or Upgrade of Metering Equipment	3
G. Load Profile Metering Requirements	3
H. Illustrations	3
Metering Configurations - Descriptions and Notes	4
CT Metering Configuration 6 - CTs in Padmounted Transformer or Vault	5
CT Metering Configuration 7, 8, 9 - CT Cabinet Mounted on Wall	6
CT Cabinet and IT Rated Meter Socket - Installation and Bonding	7
CT Metering Configuration 10 - CTs in Weatherhead Cabinet	8
CT Metering Configuration 11 - CTs in Padmounted Primary Metering Cabinet	9
CT Metering Configuration 12 - Load Profile Metering	10
Identification of Multiple Meter Sockets	11
Meter Enclosure Installations in Flood Zones	12



FPL

Electric Service Standards

DATE

02-04-05

PREPARED BY

Distribution Construction Processes

SUBJECT

TABLE OF CONTENTS

SECTION: PAGE

TOC: 3 of 3

- VII. APPROVED METERING EQUIPMENT ENCLOSURE LIST** 1
 - Notes: 1
 - Self Contained Units 2
 - Instrument Transformer Rated Units 10
 - Instrument Transformer Rated Meter Sockets 10
 - Wall Mounted Transformer Cabinets 11
 - Weatherhead Mounted Transformer Cabinets 12
 - Primary Padmounted Transformer Cabinets 12
 - Metering Equipment Cabinets 13
- VIII. GROUNDING** 1
 - A. General 1
 - B. Notes on Grounding Customer's Service Entrance 1
- IX. MOTORS, CONTROLLERS and AIR CONDITIONERS** 1
 - A. General 1
 - B. FPL Approval of Starting Means for Large Motors 1
 - C. Motor Protection and Power Factor 3
 - D. Air Conditioners that Require Excessive Starting Currents 4
- X. ELECTRICAL DISTURBANCES** 1
- XI. RADIO, TELEVISION AND MISCELLANEOUS ANTENNAS** 1
- XII. STREET & OUTDOOR SECURITY LIGHTING** 1
 - A. Street Lighting 1
 - B. Outdoor Security Lighting 2
 - C. Disconnect Devices for Customer-Owned Street/Outdoor Security Lighting 3
- XIII. SAFETY** 1
 - A. Six Safety Rules 1
 - 1. Rule 1: Work a Safe Distance 1
 - 2. Rule 2: Stay Calm – Stay Away 1
 - 3. Rule 3: Ladders and Power Lines Don't Mix 2
 - 4. Rule 4: Call Before You Dig 2
 - 5. Rule 5: Look Up and Live 3
 - 6. Rule 6: Downed Lines can be Deadly 3
 - B. Notification of FPL Facilities (Form 360) 4
 - C. Underground Utility Locating 5
 - 1. Information Needed 5
 - 2. Dig Site Location 5
 - 3. Other 5
 - 4. Color Codes 5



Electric Service Standards

DATE
07-07-11

PREPARED BY

SUBJECT

SECTION: PAGE

Distribution Construction Processes

I. DEFINITIONS

I: 1 of 2

I. DEFINITIONS

Base Rate Revenue - For use in these Standards, the non-fuel energy (kwh) and demand charge (kwd), if any, revenue resulting from the Customer's electricity use under the applicable rate schedule. Base Rate Revenue excludes, without limitation, customer charges, taxes, franchise fees; fuel, conservation, capacity payment, environmental charges; and any other charges or credits (such as TR rider, transformer rental, or load management or curtailment credits).

CIAC (Contribution in Aid of Construction) - A nonrefundable charge for electric service where (a) the extension is not justified by projected revenues and/or (b) the cost of providing underground electric facilities exceeds the cost of equivalent overhead facilities ("differential" cost), and/or (c) non-standard service, as determined by FPL, is being requested for the load being served.

Commercial Service - For purposes of these Electric Service Standards, any electric service used for non-residential purposes (excluding those applications found in FPL's "lighting" tariffs).

Customer - Any present or prospective user of FPL's electric service, or any person or entity representing him, such as the architect, engineer, electrical contractor, land developer, builder, etc.

Expected Incremental Base Revenue - The estimated Base Rate Revenue, as defined above and determined by FPL, generated on the facilities being installed or upgraded to serve the Customer.

ESS (Electric Service Standards) - The acronym referring to this publication.

FAC (Florida Administrative Code) - The official compilation of the Rules and Regulations of Florida Regulatory Agencies filed with the Dept. of State under the Provisions of Chapter 120, Fla. Statutes.

FPL - Florida Power and Light Company or an employee properly qualified to represent Florida Power and Light Company.

Ground - A conducting connection between an electrical circuit or piece of equipment and the earth, or to a conducting body that serves in place of the earth.

Meter Socket - A meter socket is a device which provides support and means of electrical connection to a watt-hour meter. It has a wiring chamber, with provisions for conduit entrances and exits, and a means of sealing the meter in place. The word "socket" in these Standards refers to meter socket.

Mobile Home - A mobile home is a factory assembled structure designed to be used as a living unit, and readily movable on its own running gear. It has no permanent foundation.

Multiple Occupancy Building - A unified structure containing five or more individual dwelling units.

Point of Delivery - The location where FPL-owned conductors are connected to customer-owned conductors. Typical points of delivery include weatherheads, meter sockets, service junction boxes, handholes, padmounted transformers, and vaults. The point of delivery shall be determined by FPL. The point of delivery for an FPL owned and maintained underground residential service lateral is the line side of the meter socket, for an FPL owned and maintained overhead service drop the point of delivery is the attachment to the customer's weatherhead.

Recreational Vehicle (RV) - A vehicle designated for temporary living quarters for camping, traveling, or recreational use. It may have its own motive power, or be mounted on or pulled by another vehicle.

Residential Service - Electric service supplied exclusively for domestic purposes in individually metered dwelling units, where permanent residency is established, including the separately metered non-commercial-use facilities of a residential customer (e.g. garages, water pumps, etc.).

Recreational Vehicle Park or Campground - An accommodation for recreational vehicles or other camping outfits where an individual site is rented, and the intent of the park or campground is not to establish permanent residencies.



FPL

Electric Service Standards

DATE

07-07-11

PREPARED BY

Distribution Construction Processes

SUBJECT

I. DEFINITIONS

SECTION: PAGE

I: 2 of 2

Secondary Network Service - A type of electric service generally available only in certain parts of downtown Miami from an existing grid of interconnected secondary conductors. This grid is fed from two or more three-phase transformers connected to different primary feeders. Service voltage from the grid is 120/208 volt, four wire wye. Spot network service (single locations or small confined areas) may be 277/480 volt, four wire wye. The network service is only available in specific locations and new secondary networks are not being constructed.

Service - The conductors and equipment that deliver energy from FPL's system to the wiring system of the premise being served. It also means maintenance of voltage and frequency (within acceptable tolerances) by FPL at the point of delivery.

Service Drop - The overhead conductors from FPL's last pole or other aerial support to and including the splices, if any, connecting the Customer's service entrance conductors at the building or other structure.

Service Entrance - The Customer's installation from the service drop or service lateral connection to and including the service equipment.

Service Entrance Conductors - The Customer's conductors from point of connection at the service drop or service lateral to the service equipment.

Service Equipment - The Customer's equipment which controls the electric service and contains the switching and overcurrent protective devices, usually located near the entry point of the service entrance conductors into the building.

Service Lateral - The underground service conductors connecting FPL's distribution system to the Customer's service entrance conductors.

Standard Service - The minimum level of service, as determined by FPL, for the load to which electric service is being requested by the Customer. Typically, this service is overhead (with wood poles), at the standard voltages specified in ESS [Section III.A](#), to the FPL designated point of delivery. Generally, any service requested of FPL that exceeds FPL's minimum level of service is paid for as a CIAC. All service is alternating current (AC) at 60 hertz (cycles per second).

Tariff - Schedule of FPL rates, charges, and General Rules and Regulations for providing electric service. FPL's Electric Tariff is available for inspection at any FPL business office, and is on file with Florida's Public Service Commission (FPSC). The word "Tariff" in these Standards refers to FPL's Electric Tariff.

Temporary/Construction Service - Limited term electric service to operations such as: Exhibitions, Construction Projects, Fairs, Holiday Lighting, Dredging Jobs, etc.

Transformer Vault - An isolated enclosure, with fire resistant walls, ceilings and floor, in which transformers and related equipment are installed and not continuously attended during operation.

Underground Distribution - A distribution system where the conductors are buried with or without enclosing ducts. Newer systems are in conduit. Transformers, switches and other equipment are normally above ground, or enclosed in vaults or other enclosures.

URD - (Underground Residential Distribution) - An underground distribution system, primarily supplying single phase, three wire service laterals to residential dwelling units. Most conductors are buried and new systems are in conduit. Transformers and primary switches are contained in above ground padmounted enclosures.



FPL

Electric Service Standards

DATE
07-12-11

PREPARED BY

SUBJECT

SECTION: PAGE

Distribution Construction Processes

II. GENERAL

II: 1 of 12

II. GENERAL

A. Early Notification and Coordination

FPL - As used in these Standards, the word "FPL" represents FPL Company or any employee properly qualified to represent FPL Company.

Customer - For the purpose of these Standards, the word "Customer" represents any present or prospective user of FPL's electric service, or any person or entity representing him, such as the architect, engineer, electrical contractor, land developer, or builder, etc.

Contacting FPL - FPL maintains offices throughout its service area. New extensions of electric facilities to serve customers, or modifications to existing electric facilities, are generally handled by FPL's Construction Department. Information concerning a specific installation should be requested by the Customer from FPL's nearest Construction office. Locations are listed at the end of this section. **Early Contact** with FPL is **necessary** to ensure provision of electric service in as timely a fashion as possible.

Close coordination is necessary throughout the planning and construction stages by FPL and the Customer, or those representing him. Particular attention shall be given to the scheduling of the construction of paved areas and the various sub grade installations of the several utilities.

FPL strives to supply its Customers' needs for electric service as efficiently, reliably and economically as possible. Although this publication provides many of the guidelines concerning FPL's character of service and policies, it is not possible to document all the detailed information the Customer may require. **This publication is not intended to replace direct communication with FPL.** Contact with FPL during the **early** stages of the Customer's design is **strongly** encouraged to avoid misunderstanding, delays, and unnecessary expense.

A Notification of New Construction form is available upon request for use by the Customer to facilitate the exchange of information between FPL and the design professionals on large projects.

B. Application for Electric Service

Application for electric service shall be well in advance of the date service will be required. All matters pertaining to the use of electric service should be discussed with FPL at that time. Depending on the service requested, a standard written agreement between the Customer and FPL may be required. Depending on the type of premise or load being served, any or all of the following Information may be required of the Customer:

1. Exact location of premise to be served (i.e., site plan, recorded plat, street address, lot, block number and legal description of property)
2. Size of air conditioning, heating, water heating, cooking, etc; type and voltage of other motor load, number of phases, horsepower; street lighting, traffic signals, etc.
3. Mechanical plans, electrical plans, elevations, etc.
4. Utility (water, sewer, gas, etc.) plans and paving & drainage plans
5. Any special or unusual requirements

Every reasonable effort will be made by FPL to reach a prompt and mutually satisfactory arrangement with the Customer regarding the characteristics of the service to be furnished and the designated point of delivery.



Electric Service Standards

DATE
07-12-11

PREPARED BY
Distribution Construction Processes

SUBJECT
II. GENERAL

SECTION: PAGE
II: 2 of 12

C. Availability of Desired Type of Electric Service

Contact with FPL **early** in the Customer's planning stage is **strongly** encouraged to determine availability of service at any location, FPL's standard type of service for the load to be served, and the designated point of delivery. If the standard type of service does not meet the Customer's requirements, FPL will consider supplying the requested type of service, subject to availability, providing the manner of use does not jeopardize the quality of service to others. It may be necessary for the Customer to compensate FPL for any incremental costs of supplying such service. If special FPL equipment is needed, adequate time shall be allowed to obtain it.

Written information concerning availability and character of service for any desired location will be supplied by FPL. FPL will not be responsible for mistakes resulting from information given orally.

Contact with FPL **early** in the Customer's design stage is essential so that engineering, material procurement, and job scheduling may be performed in a manner conducive to providing timely service to the customer. Any change in plans that is likely to affect the electric service should be communicated to FPL at once. Failure to do so may result in unnecessary delays and/or expense.

D. Contributions by Customer

Throughout these standards, references are made to customer Contributions In Aid of Construction (CIAC), whereby the customer pays for a portion of the requested service. In all cases, ownership of the requested facility remains with FPL, and payments are required **well in advance** of FPL's construction, allowing for proper scheduling. Contact your FPL representative concerning the "timing" of the payment. Withholding payment until the latter stages of a project's development may cause unnecessary delays and added expense to the Customer.

In the event trenching and conduit are involved, the customer may provide the trench and/or install the FPL provided PVC conduit, where mutually agreed upon by the customer and FPL. The Customer will receive a credit, as determined by FPL, for such work. Typically, the credit will be granted after the work has been inspected by FPL and, in the case of customer installed conduit, after FPL pulls the cable.

E. Rights of Way and Easements

The customer shall furnish and record satisfactory rights of way and easements, including legal descriptions of such easements and all survey work associated with producing legal descriptions of such easements, as required by and at no cost to FPL before FPL commences construction. Only the unaltered FPL standard form 3722 will be accepted for easements. Before FPL starts construction, these rights of way and easements shall be cleared by the customer of trees, tree stumps and other obstructions that conflict with construction, staked to show property corners and survey control points, graded to within six inches of final grade, with soil stabilized. In addition, the customer shall provide stakes showing final grade along the easement. Such clearing and grading shall be maintained by the customer during construction by FPL.

Where plats are concerned, FPL requests the plat be presented before recording so provisions for easements can be included on the plat. This will minimize, if not eliminate, future costs associated with producing, securing, and recording the easement(s).

When building additions to existing structures, care shall be taken not to encroach upon FPL's easements. Violation of FPL's granted easements may result in legal consequences to the building owner. FPL should be contacted early in the design and planning stage in order to determine if changes to FPL's existing easement are required.



F. Measuring (Metering) Electric Consumption

1. FPL's individual electric metering requirements are set forth in Florida Administrative Code 25-6.049, which states in sections (5) through nine (9):

(5) Individual electric metering by the utility shall be required for each separate occupancy unit of new commercial establishments, residential buildings, condominiums, cooperatives, marinas, and trailer, mobile home and recreational vehicle parks. However, individual metering shall not be required for any such occupancy unit for which a construction permit was issued before, and which has received master-metered service continuously since January 1, 1981. In addition, individual electric meters shall not be required:

(a) In those portions of a commercial establishment where the floor space dimensions or physical configuration of the units are subject to alteration, as evidenced by non-structural element partition walls, unless the utility determines that adequate provisions can be made to modify the metering to accurately reflect such alterations;

(b) For electricity used in central heating, ventilating and air conditioning systems, or electric back up service to storage heating and cooling systems;

(c) For electricity used in specialized-use housing accommodations such as hospitals, nursing homes, living facilities located on the same premises as, and operated in conjunction with, a nursing home or other health care facility providing at least the same level and types of services as a nursing home, convalescent homes, facilities certificated under Chapter 651, F.S., college dormitories, convents, sorority houses, fraternity houses, and similar facilities;

(d) For lodging establishments such as hotels, motels, and similar facilities which are rented, leased, or otherwise provided to guests by an operator providing overnight occupancy as defined in paragraph (8)(b);

(e) For separate, specially-designated areas for overnight occupancy, as defined in paragraph (8)(b), at trailer, mobile home and recreational vehicle parks and marinas where permanent residency is not established;

(f) For new and existing time-share plans, provided that all of the occupancy units which are served by the master meter or meters are committed to a time-share plan as defined in Chapter 721, F.S., and none of the occupancy units are used for permanent occupancy.

(g) For condominiums that meet the following criteria:

1. The declaration of condominium requires that at least 95 percent of the units are used solely for overnight occupancy as defined in paragraph (8)(b) of this rule;

2. A registration desk, lobby and central telephone switchboard are maintained; and

3. A record is kept for each unit showing each check-in and check-out date for the unit, and the name(s) of the individual(s) registered to occupy the unit between each check-in and check-out date.

(6) Master-metered condominiums.

(a) Initial Qualifications – In addition to the criteria in paragraph (5)(g), in order to initially qualify for master-metered service, the owner or developer of the condominium, the condominium association, or the customer must attest to the utility that the criteria in paragraph (5)(g) and in this subsection have been met, and that any cost of future conversion to individual metering will be the responsibility of the customer, consistent with subsection (7) of this rule. Upon request and reasonable notice by the utility, the utility shall be allowed to inspect the condominium to collect evidence needed to determine whether the condominium is in compliance with this rule. If the criteria in paragraph (5)(g) and in this subsection are not met, then the utility shall not provide master-metered service to the condominium.

(b) Ongoing Compliance – The customer shall attest annually, in writing, to the utility that the condominium meets the criteria for master metering in paragraph (5)(g). The utility shall establish the date that annual compliance materials are due based on its determination of the date that the criteria in paragraphs



Electric Service Standards

DATE
07-12-11

PREPARED BY
Distribution Construction Processes

SUBJECT
II. GENERAL

SECTION: PAGE
II: 4 of 12

(5)(g) and (6)(a) were initially satisfied, and shall inform the customer of that date before the first annual notice is due. The customer shall notify the utility within 10 days if, at any time, the condominium ceases to meet the requirements in paragraph (5)(g).

(c) Upon request and reasonable notice by the utility, the utility shall be allowed to inspect the condominium to collect evidence needed to determine whether the condominium is in compliance with this rule.

(d) Failure to Comply – If a condominium is master metered under the exemption in this rule and subsequently fails to meet the criteria contained in paragraph (5)(g), or the customer fails to make the annual attestation required by paragraph (6)(b), then the utility shall promptly notify the customer that the condominium is no longer eligible for master-metered service. If the customer does not respond with clear evidence to the contrary within 30 days of receiving the notice, the customer shall individually meter the condominium units within six months following the date on the notice. During this six month period, the utility shall not discontinue service based on failure to comply with this rule. Thereafter, the provisions of Rule 25-6.105, F.A.C., apply.

(7) When a structure or building is converted from individual metering to master metering, or from master metering to individual metering, the customer shall be responsible for the costs incurred by the utility for the conversion. These costs shall include, but not be limited to, any remaining undepreciated cost of any existing distribution equipment which is removed or transferred to the ownership of the customer, plus the cost of removal or relocation of any distribution equipment, less the salvage value of any removed equipment.

(8) For purposes of this rule:

(a) "Occupancy unit" means that portion of any commercial establishment, single and multi-unit residential building, or trailer, mobile home or recreational vehicle park, or marina which is set apart from the rest of such facility by clearly determinable boundaries as described in the rental, lease, or ownership agreement for such unit.

(b) "Overnight Occupancy" means use of an occupancy unit for a short term such as per day or per week where permanent residency is not established.

(9)(a) Where individual metering is not required under subsection (5) and master metering is used in lieu thereof, reasonable apportionment methods, including sub-metering may be used by the customer of record or the owner of such facility solely for the purpose of allocating the cost of the electricity billed by the utility. The term "cost" as used herein means only those charges specifically authorized by the electric utility's tariff, including but not limited to the customer, energy, demand, fuel, conservation, capacity and environmental charges made by the electric utility plus applicable taxes and fees to the customer of record responsible for the master meter payments. The term does not include late payment charges, returned check charges, the cost of the customer-owned distribution system behind the master meter, the customer of record's cost of billing the individual units, and other such costs.

(b) Any fees or charges collected by a customer of record for electricity billed to the customer's account by the utility, whether based on the use of sub-metering or any other allocation method, shall be determined in a manner which reimburses the customer of record for no more than the customer's actual cost of electricity.

(c) Each utility shall develop a standard policy governing the provisions of sub-metering as provided for herein. Such policy shall be filed by each utility as part of its tariffs. The policy shall have uniform application and shall be nondiscriminatory.



G. Conjunctive Billing or Totalized Metering as disallowed in FAC 25-6.102

- (1) Conjunctive billing means totalizing metering, additive billing, plural meter billing, conjunctive metering, and all like or similar billing practices which seek to combine, for billing purposes, the separate consumptions and registered demands of two or more points of delivery serving a single customer.
- (2) A single point of delivery of electric service to a user of such service is defined as the single geographical point where a single class of electric service, as defined in a published rate tariff, is delivered from the facilities of the utility to the facilities of the customer.
- (3) **Conjunctive billing shall not be permitted.** Bills for two or more points of delivery to the same customer shall be calculated separately for each such point of delivery.
- (4) A customer operating a single integrated business* under one name in two or more buildings and/or energy consuming locations may request a single point of delivery and such request shall be complied with by the utility providing that:
 - (a) Such buildings or locations are situated on a single unit of property; or
 - (b) Such buildings or locations are situated on two or more units of property which are immediately adjoining, adjacent or contiguous; or
 - (c) Such buildings or locations are situated on two or more units of property, which are immediately adjoining, adjacent or contiguous except for intervening streets, alleys or highways.

In all cases arising in sub-paragraph (a), (b), or (c), it shall be the customer's responsibility to provide the electrical facilities necessary for distributing the energy beyond the single delivery point [or pay to FPL a monthly rental fee for FPL-owned facilities beyond the meter].

*The word "business" as used in this section shall be construed as including residences and educational, religious, governmental, commercial, and industrial operations.

H. Electrical Inspections and Connection of Service

When a Customer's electrical installation has been completed, it shall be inspected by the local electrical inspector to ensure compliance with the National Electrical Code and such local rules that may apply. FPL cannot energize new service installations until such inspection has been made, and until formal notice from the inspecting authority has been received by FPL.

I. Customer Responsibility for Safety and Adequacy of Wiring

Electric service is rendered to the Customer with the understanding that he will not use any appliance or device which is not properly constructed, controlled and protected, or that may adversely affect service rendered to him or other Customers. FPL shall reserve the right to discontinue or refuse service to any apparatus or device, which in its opinion, may adversely affect the service to any other Customer or utility or that may be of an improper or unsafe type (FAC 25-6.105), even if the inspection, as mentioned in paragraph "H" above, has been received by FPL. However, FPL assumes no responsibility whatsoever for any portion of the Customer's wiring installation, FPL depends upon the local inspecting authority to ensure the adequacy of the wiring on the customers premise.

Compliance with the National Electrical Code, National Electrical Safety Code and local codes ensures that the installation conforms to recognized minimum safe practices. It is the responsibility of the Customer to comply with all Code requirements.



Electric Service Standards

DATE
07-12-11

PREPARED BY
Distribution Construction Processes

SUBJECT
II. GENERAL

SECTION: PAGE
II: 6 of 12

The Customer shall decide whether additional capacity should be provided for future load growth. In general, FPL recommends that an adequate margin for load growth be provided.

J. Access to FPL Facilities

Access to the Customer's premise shall be provided for the purpose of reading meters, installing, maintaining, inspecting or removing FPL's property, and other purposes incident to performance under or termination of FPL's agreement with the Customer, and in such performance, FPL or its representatives shall not be liable for trespass.

All employees of FPL who may have business on the Customer's property are required to identify themselves as FPL employees upon request. If anyone representing himself as an employee of FPL cannot produce identification, FPL is to be notified at once.

K. Load Balance

To prevent overloading the service conductors and transformer coils, the Customer's electrical load shall be properly balanced on the service entrance conductors and service equipment.

On 120/240 volt, four wire delta services, the conductor identified as high voltage to ground, commonly known as the "high leg" or "power leg", would be used only to feed into a three phase load circuit and not as a phase to ground.

L. Customer Owned Generators

1. Standby Generator

In some cases, the Customer may wish to provide an emergency 60 hertz generator to supply a portion, or all, of his electric service in the event of failure of FPL's service.

A device which meets the National Electrical Code and is listed and labeled by a Nationally Recognized Test Lab (NRTL), such as U.L., to a standard equal to U.L. 1008 Transfer Switch Equipment, or listed and labeled to one of the following;

- U.L. 67 Panel boards
- U.L. 98 Enclosed switches
- U.L. 891 Switchboards

AND, the device is also labeled as "Suitable for use as transfer equipment in accordance with article 702 of the NEC" or similar verbiage indicating that it can be used as transfer equipment. Note: the second label, referring to the using the device as transfer equipment, will not have a U.L. mark on the label, but still meets U.L. by the existence of the first label.

This switch shall be provided by the customer and shall disconnect the Customer's service equipment from FPL's lines before connecting it to the emergency generator.

2. Parallel Generation and Cogeneration

FPL approval is required where the Customer is considering the use of Cogeneration (the simultaneous production in one facility of electricity and other useful forms of energy such as steam or heat) or small power producer generation (i.e., those using renewable resource fuel sources) if it is to connect to FPL's system. Consult with FPL for further details.

Customers considering the installation of generating equipment intended to supply a portion or all of their electric service, shall consult with FPL regarding the design, installation and the



FPL

Electric Service Standards

DATE
07-12-11

PREPARED BY

SUBJECT

SECTION: PAGE

Distribution Construction Processes

II. GENERAL

II: 7 of 12

operation of this generating equipment. Momentary parallel generation is limited to 100ms maximum. Generation other than cogeneration and small power producers shall not operate in parallel with FPL's systems without proper protective equipment for the interconnection as outlined by FPL. The Customer's system design shall be submitted for review and approval by FPL before any connection is made. The Customer is responsible for the full cost of any modifications to FPL's facilities necessary to accommodate the Customer's system.

Caution: FPL shall be consulted before any type of generating or communications equipment is installed and connected to any circuit which is or could be fed from FPL's distribution system.

M. Unauthorized Attachments

FPL prohibits any attachments to its poles or other equipment unless specifically authorized by agreement. Such attachments include, but are not limited to fences, banners, signs, clotheslines, basketball backboards, antennas, placards, political posters or any advertising matter. FPL will remove unauthorized attachments without notice. Meter sockets and Customer's electric service risers are not to be attached to FPL poles, except where permitted by FPL.

Customer owned secondary capacitors or lightning surge arresters may not be installed inside or outside the meter socket or connected to FPL's conductors. It is suggested these devices be installed in, or adjacent to, the customer's disconnect panel(s) on the load side of the main line switch. Also, external grounding bars and other devices are not allowed to be attached to the outside of the meter enclosure.

FPL forbids any work on or access to any of its facilities without authorization.

N. Continuity of Service

FPL strives to furnish reliable, dependable service at a reasonable cost. It cannot guarantee service continuity, however, and provides service in accordance with standards set forth in its Electric Tariff. Some Customers may have equipment which cannot tolerate an occasional interruption. They may wish to invest in a standby system which will supply uninterrupted power upon failure of FPL's service, or when transient interruptions occur.

Some computer based systems are sensitive to short voltage spikes or dips on the normal 60 hertz voltage wave. Very short interruptions caused by a fast opening and closing of an FPL circuit breaker may also affect these systems. These transients are unavoidable on a distribution system serving many and varied customer loads and subject to the natural elements. The Customer should consider these conditions as part of his electric service environment. He should choose equipment which can operate satisfactorily in this environment or purchase suitable power conditioning equipment such as an uninterruptible power supply.

O. Conservation Programs

FPL offers conservation incentive programs to help customers reduce energy costs. While helping customers manage electricity more efficiently, FPL reduces the purchase of expensive fuel oil and delays power plant construction, thus reducing costs. Customers can obtain conservation incentive information by calling the phone number listed on their electric bill.

P. Contacting FPL

FPL Customer Service may be contacted 24 hours a day by calling the number on the bottom of your bill or the number in your local phone book. Contact regarding new construction and changes in service requirements (service changes) should be directed to your local FPL Construction Service Planning Office which is open during normal business hours. The following pages list FPL's Construction Service Planning Offices and the approximate areas they serve.



Electric Service Standards

DATE
07-12-11

PREPARED BY
Distribution Construction Processes

SUBJECT
II. GENERAL

SECTION: PAGE
II: 8 of 12

SOUTH COAST (BROWARD AND DADE COUNTIES)

North Broward Construction Services
Pompano Service Center
330 S.W. 12th Avenue
Pompano Beach, FL 33069
(954) 956-2014 fax (954) 956-2020

North of Commercial Blvd to the Palm Beach County Line

Central Broward Construction Services
Wingate Service Center
3020 N.W. 19th Street
Fort Lauderdale, FL 33111
(954) 717-2072 fax (954) 717-2118
(954) 717-2093 – Disco/Reco Only

East of the Turnpike: south of Commercial Blvd & north of Griffin Road; **East of I-95:** to Intercoastal Waterway between Dania Cutoff Canal to Griffin Rd; **West of the Turnpike:** south of Commercial Blvd & north of I-595

South Broward Construction Services
Gulfstream Service Center
4000 Davie Road Extension
Hollywood, FL 33024
(954) 442-6352 fax (954) 442-6340
(954) 442-6351 – Disco/Reco Only

East of Turnpike: south of Griffin Rd to the Dade County Line less section between I-95 and Intercoastal, Dania Cut-Off Canal to Griffin Rd; West of Turnpike: south of I-595 to the Dade County Line

Northeast Construction Services
18455 N.E. 2 Avenue
North Miami Beach, FL 33179
(305) 770-7900 fax (305) 770-7996

Northern Dade County east of Florida's Turnpike including Carol City, Golden Beach, North Miami, North Miami Beach, and Opa Locka, Bal Harbor, Indian Creek Village, Miami Shores, North Bay Village, El Portal, Surfside, Bay Harbor Islands, Biscayne Park

West Dade Construction Services
6195 N.W. 82 Avenue
Miami, FL 33166
(305) 599-4000 fax (305) 599-4014

The area bounded by SW 24 Street (Coral Way) from the west to SW 57 Avenue, north to the Airport Perimeter Road continue along City of Miami west boundary then north to NW 62 Street, west to NW 42 Avenue (East 8 Avenue) north to Gratigny Road west to NW 57 Avenue, north to West 84 Street, west to I-75 and north to the Miami-Dade County – Broward County line

Central Construction Services
122 S.W. 3 Street
Miami, FL 33130
(305) 377-6001 fax (305) 377-6010

Coconut Grove, Coral Gables, Indian Creek Village, Key Biscayne, Miami, Miami Beach, North Bay Village

South Dade & Richmond Construction Services
14250 S.W. 112 Street
Miami, FL 33186
(305) 387-6650 fax (305) 387-6651

All of Dade County south and west of a line beginning at Biscayne Bay and SW 88 Street, west to SW 57 Avenue, north to SW 8 Street and west to the Dade County Line



FPL

Electric Service Standards

DATE

07-12-11

PREPARED BY

Distribution Construction Processes

SUBJECT

II. GENERAL

SECTION: PAGE

II: 9 of 12

**WEST COAST
(WEST OF LAKE OKEECHOBEE FROM MANATEE COUNTY SOUTH)**

Whitfield Construction Services
1253 12th Ave E
Palmetto, FL 34221
(941) 723-4420 fax (941) 723-4444

Covers Manatee County

Clark Construction Services
5657 South McIntosh Road
Sarasota, FL 34233
(941) 927-4251 or 4252 fax (941) 927-4266

Covers Sarasota County, south to Alligator Creek in Venice

Toledo Blade Construction Services
2245 Murphy Court
North Port, FL 34286
1-800-375-8805 or 1-800-375-8490
fax 1-800-375-7680 or (941) 423-4839

South of Alligator Creek in Venice, Boca Grande, Englewood, Gulf Cove, Placida, and Rotonda, El Jobean, North Port, Port Charlotte, Warm Mineral Springs, Arcadia, Deep Creek, Harbor Heights and Punta Gorda

Lee County, North of Colonial Blvd, east to I-75 then south to Daniels Rd along East side of I-75. North side of Daniels Rd through a portion of Lehigh Acres and Buckingham. SR 80 from the Lee County line to Oxbow at Port Labelle and SR 29 from SR 78 to Keri Road, plus in Glades County, CR 731 to CR 720 to Muse and then along CR 720 to the Charlotte County line and SR 29 to SR 78 and then along SR 78 to Old Moorehaven Road.

Gladiolus Construction Services
15834 Winkler Road
Fort Myers, FL 33908
(239) 415-1302
fax (239) 415-1350

Lee County, south of Colonial Blvd, east to I-75 then South to Daniels Rd, then the south side of Daniels Rd east to Green Meadows Rd.

Golden Gate Construction Services
4105 S.W. 15 Avenue
Naples, FL 34116
(239) 353-6010, 6090 or 6091
fax (239) 353-6082

Lee and Collier Counties from south of Corkscrew Road and the Estero River to north of the Marco Island Bridge, and east to Desoto Boulevard and East Hamilton Rd on US 41 East. Northeast boundary is 41 Ave NE North of Immokalee Rd.



Electric Service Standards

DATE
07-12-11

PREPARED BY
**Distribution Construction
Processes**

SUBJECT
II. GENERAL

SECTION: PAGE
II: 10 of 12

NORTHEAST COAST (NORTH OF BROWARD/PALM BCH COUNTY LINE)

Nassau Construction Services
S.R. A1A & Griffin Road
P.O. Box 2019
Callahan, FL 32011
1-800-462-0561 fax 1-800-631-2996

Callahan, Fernandina Beach, Hilliard and Yulee;
Nassau County

Lake City Construction Services
2618 NE Bascom Norris Dr
Lake City, FL 32055
1-800-462-0561 fax 1-800-631-2996

Houston, Lake City, Live Oak, Olustee, and
Wellborn;
Columbia and Suwannee County

Starke Construction Services
351 Colley Road
Starke, FL 32091
1-800-462-0561 fax 1-800-631-2996

Bryceville, Hampton, Kingsley Lake, Lake Butler,
Lawtey, Macclenny, Penney Farms, Raiford,
Sanderson, Starke, and Waldo;
Baker, Bradford, Clay and Union Counties

St. Augustine Construction Services
303 Hastings Road
St. Augustine, FL 32086
1-800-345-2503 or (904) 824-7615
fax (904) 824-7620

St. Johns County south of CR 210, south of
Guana State Park on A1A, plus small portions of
Northern Flagler County

Palatka Construction Services
2900 Catherine Street
Palatka, FL 32177
1-800-345-2503 or (904) 824-7615
fax (904) 824-7620

Town of Hawthorne, Putnam County, a portion
of St. Johns County and a small portion of
Flagler County

Flagler Construction Services
5910 East Highway 100
Palm Coast, FL 32164
1-866-487-0428 fax (386) 586-6404

Flagler County and Volusia County north of SR
40

Port Orange Construction Services
3000 Spruce Creek Road
Port Orange, FL 32119
(386) 322-3420 or 3428 fax (386) 322-3444

Daytona Bch, Daytona Bch Shores, Edgewater,
Holly Hill, Oak Hill, Ormond Beach south of SR
40, Port Orange, S. Daytona, Volusia County
area around New Smyrna Beach

Sanford Construction Services
2626 West S.R. 46
P.O. Box 2149
Sanford, FL 32772
1-800-741-1424
fax (407) 328-1910

Chuluota, Geneva, Sanford Area and small
portions of Deltona, Heathrow, Lake Mary and
Oviedo

Brevard Construction Services
9001 Ellis Road
Melbourne, FL 32904-1056
(321) 726-4801 or 4802; or, 1-800-577-1156
fax (321) 726-4880

Brevard County



FPL

Electric Service Standards

DATE

07-12-11

PREPARED BY

Distribution Construction Processes

SUBJECT

II. GENERAL

SECTION: PAGE

II: 11 of 12

**NORTHEAST COAST (Cont.)
(NORTH OF BROWARD/PALM BCH COUNTY LINE)**

Treasure Coast Construction Services
Walton Service Center
1050 S.E. Brandon Circle
Port St. Lucie, FL 34952
(772) 337-7049
1-800-343-7941 fax (772) 337-7099

Midway road (St. Lucie County) south to Roosevelt bridge in Stuart, includes Port St. Lucie, Jensen Beach and Hutchinson Island from Jensen Causeway to St. Lucie Power Plant

Treasure Coast Construction Services
Okeechobee Service Center
825 N.E. 34 Avenue
Okeechobee, FL 34972
(863) 467-3708 or 1-800-666-5718
fax (863) 467-3716

Okeechobee, Indiantown west of Martin Power Plant, Port Mayaca west of the bridge, Whispering Pines, Fort Drum, Brighton Reservation, Buckhead Ridge, portions of Glades and Highlands counties

Treasure Coast Construction Services
St. Lucie Service Center
3301 Orange Avenue
Fort Pierce, FL 34947
(772) 489-6254 or 1-800-757-5487
fax (772) 489-6224

Indian County Line south to Midway Road, Fort Pierce (St. Lucie County), includes Sebastian, Fellsmere, Wabasso, Vero Beach, and Fort Pierce

Treasure Coast Construction Services
Stuart Service Center
4406 SW Cargo Way
Palm City, FL 34990
(772) 223-4208 or 1-800-666-5718
fax (772) 223-4225

South of Roosevelt Bridge in Stuart to Jonathon Dickinson State Park in Hobe Sound, Palm City, Jupiter Island, Indiantown east of Martin Power Plant, Port Mayaca east of the bridge, and Hutchinson Island south of Jensen Causeway

Jupiter Construction Services
100 Delaware Avenue
Jupiter, FL 33458
(561) 575-6340 fax (561) 575-6333

North of Blue Heron Blvd and north of Beeline Hwy to the Martin County Line

West Palm Beach Construction Services
810 Charlotte Avenue
West Palm Beach, FL 33401
(561) 616-1601 or 1602 fax (561) 616-1625

Lake Worth Road north to Blue Heron Blvd, east of Florida's Turnpike in West Palm Beach

Royal Palm Beach Construction Services
500 Business Park Way
Royal Palm Beach, FL 33411
(561) 790-5046 fax (561) 790-5075

South of Beeline Hwy, west of Florida's Turnpike, north of Lake Worth and Lantana Roads and east of the L-8 and L-40 Canals

Boynton Construction Services
9329 South Military Trail
Boynton Beach, FL 33436
(561) 742-2000 fax (561) 742-2016

Lake Worth Road south to the north side of Atlantic Avenue



Electric Service Standards

DATE

07-12-11

PREPARED BY

SUBJECT

SECTION: PAGE

Distribution Construction Processes

II. GENERAL

II: 12 of 12

NORTHEAST COAST (Cont.) (NORTH OF BROWARD/PALM BCH COUNTY LINE)

Boca Raton Area Construction Services
21400 Powerline Rd
Boca Raton, FL 33433
(561) 479-4553 fax (561) 479-4588

Atlantic Avenue south to the Broward County Line

Belle Glade Construction Services
1318 W. Avenue A
Belle Glade, FL 33430
(561) 992-5907 fax (561) 992-5915

From the Martin county line south to the Broward county line and from the Industrial canal (just east of Clewiston) west to the 20 mile bend on State Road 80



Electric Service Standards

DATE
07-07-11

PREPARED BY

SUBJECT

SECTION: PAGE

Distribution Construction Processes

III. SERVICE PROVISIONS

III: 1 of 11

III. SERVICE PROVISIONS

A. Standard Service

FPL's standard service is that supplied by overhead lines, with wood poles, to FPL's designated point of delivery, at the standard voltages specified below. All service is alternating current at 60 hertz (60 cycles per second). All voltages and frequencies mentioned are nominal values.

Single phase, three wire 120/240 volt service is furnished for ordinary lighting loads, household equipment, small appliances and motors. This voltage is standard throughout FPL's service area for residences and for commercial and industrial applications where three phase service is not required, in the opinion of FPL, or available. Three phase service will be provided where available, or where in the opinion of FPL, the use of single phase is impractical. This, as is all service, is subject to the line extension provisions of [section III.C](#). Devices to convert single phase to three phase can be obtained for a wide range of three phase motors, therefore availability of three phase service for smaller motors should be discussed in advance with FPL.

Voltages Under 600V - In most locations, FPL's overhead secondary distribution system provides service at the following standard voltages:

- Single phase, 120 volt, two wire
- Single phase, 480 volt, two wire (street lighting)
- Single phase, 120/240 volt, three wire
- Single phase, 240/480 volt, three wire
- Three phase, 120/240 volt, four-wire delta

In some locations, FPL's system is able to provide service at the following voltages:

- Three phase, 120/208 volt, four wire wye
- Single phase, 120/208 volt, three wire (from a three phase, four wire wye system)
- Three phase, 277/480 volt, four wire wye

120/240 volt, four-wire delta is determined by FPL to be the standard 3 phase voltage for loads in which individual motor sizes are greater than or equal to 7.5 hp (but not exceeding 20 hp), or, the 3 phase "demand" load does not exceed 75 KVA, or, the "total" demand load does not exceed 150 KVA, **and** the use of single phase, in the opinion of FPL, is impractical. When the Customer desires three phase, 120/208 or 277/480 volt will be considered the standard voltage only where, in the opinion of FPL, three phase service is required, **and** 120/240 volt delta service is not, in the opinion of FPL, the standard voltage for the load being served, unless otherwise mutually advantageous to both FPL and the Customer.

Voltages Over 600V - Service requirements for installations requiring higher distribution voltages (primary voltages) are subject to special negotiation between the Customer and FPL. Customers accepting primary voltage will provide, through ownership or rental, all distribution facilities required beyond the metered point, and, all facilities required for reducing or increasing the FPL supplied voltage to any other voltage which he may require.

If the customer plans to lease higher voltage transformers from FPL, the voltages for transformers available through FPL are:

- Single phase, 2400/4160 volt*
- Single phase, 7620/13,200 volt**
- Single phase, 13,200/22,860 volt***
- Three phase, 2400/4160 volt grounded wye
- Three phase, 7620/13,200 volt grounded wye
- Three phase, 13,200/22,860 volt grounded wye

(For connection phase to neutral to a grounded wye system rated: *2400/4160 volts; **7,620/13,200 volts; ***13,200/22,860 volts)

Typically, where the customer requests service considered by FPL to be non-standard for the load being served, the Customer will bear the additional expense as a CIAC.



Electric Service Standards

DATE
07-07-11

PREPARED BY
Distribution Construction
Processes

SUBJECT
III. SERVICE PROVISIONS

SECTION: PAGE
III: 2 of 11

B. Point of Delivery

The point of delivery is defined as that location where FPL's electric facilities connect to those of the Customer's. FPL will give considerable weight to the Customer's preference, but shall reserve the right to designate this location. Should the Customer request a location other than that designated by FPL, and FPL approves, the Customer shall be responsible for all additional costs to extend beyond FPL's designated point.

C. Extension of FPL's Electric Facilities

1. **General** - Amounts due as Contributions In Aid of Construction (CIAC) from customers who require extensions or "upgrades" of distribution facilities are calculated in accordance with Florida Administrative Code (FAC) Section 25-6.064 and FPL's Tariff (General Rules and Regulations paragraph 2.2).
2. **Overhead Extensions** - FPL extends or upgrades its overhead facilities at no charge if:
 - a. the facilities being built are for standard service for the load being served, **and**
 - b. FPL's expenditure is supported by the Estimated Annual base rate Revenue (EAR)

Other factors that may affect the approval of the extension include:

- The potential of other customers to be served from the same extension or addition within a five year period
- The permanency of the installation being served
- The expected completion date of the project
- The need to improve facilities at or near the area to be served such that the line extension can be installed
- Issuance of a construction permit
- Examination of architectural plans

A nonrefundable Contribution in Aid of Construction (CIAC) will be required for any overhead extension where the total estimated job cost for the extension or upgrade (excluding service drops and meters) required to provide **standard service**, as determined by FPL, exceeds four (4) times the estimated annual base rate revenue (EAR). This CIAC amount is equal to the difference between that estimated total job cost (excluding service drops and meters) and four (4) times the EAR. For upgrade of facilities, the customer is also charged for the Net Book Value of the existing facilities and receives a credit for salvageable items. If the customer requests facilities that are not typically required, in the opinion of FPL, to serve the load, a CIAC in addition to the above difference will also be required. This **additional** amount is equal to the difference (including service drops and meters) between FPL's estimated cost to provide the standard service and the estimated cost of the non-standard service requested by the Customer.

3. **Underground Extensions** - Where, in FPL's opinion, overhead distribution facilities are typically provided to serve the load for which service is requested, but underground is provided instead (due to Customer request or the requirement of a governmental agency), a CIAC is required which is equal to the difference between the total estimated cost to provide the overhead **standard** service and the total estimated cost of the underground. This differential cost includes all service drops and meters.

Furthermore, if the cost of the overhead system for standard service could not have been supported by estimated base rate revenue, the Customer would pay an **additional** CIAC amount equal to the difference between that total estimated job cost (excluding service drops and meters) and four (4) times the EAR.



Electric Service Standards

DATE
07-07-11

PREPARED BY

SUBJECT

SECTION: PAGE

Distribution Construction Processes

III. SERVICE PROVISIONS

III: 3 of 11

D. Residential Service (under 600v)

A single, one phase, 120/240 volt, three wire overhead service drop per lot is the standard service offered by FPL to residential customers. Excluding any extension charges that might apply (**section III.C.2**) this service is offered at no charge to FPL's designated point of delivery. Three phase service may be available but only under special circumstances and CIAC charges might apply.

FPL will provide residential underground electric service upon request when the Customer or developer pays the difference between the estimated cost of underground and the estimated cost of overhead facilities, as defined in FPL's General Rules and Regulations for Electric Service and Underground Residential Tariff. The charges quoted in the Tariff are based on conditions which permit employment of rapid construction techniques. This Tariff applies to all residential customers, including those where underground is required by local ordinance.

Underground residential service is offered under the provisions of the Residential Tariff for:

- New subdivisions, known as URD (Underground Residential Distribution) Subdivisions
- New underground service laterals from overhead systems
- Replacement of existing overhead and underground service laterals
- New multiple occupancy residential buildings

1. Underground Service for New Residential Subdivisions (Less than 5 units per building)

When requested, FPL will provide underground distribution facilities in accordance with its standard practices, in (a) recognized new residential subdivisions of five or more building lots and (b) tracts of land upon where five or more separate dwelling units are to be located.

Developers of new URD subdivisions are to contact FPL before the platting process so easements can be included in the plat. Survey work associated with producing legal descriptions of such easements for FPL facilities is to be completed by the developer's surveyor where needed. Early notice also enables FPL to design an efficient URD system and consider preferences the developer may have concerning the location of FPL facilities.

FPL will normally provide the trench and backfill for all its underground distribution facilities, including service laterals. The Customer will provide and install the service entrance conduit (downpipe), the meter socket, and the wiring from the meter socket to the service entrance equipment (**Fig. IV-11a,b**). If the Customer wants to trench, backfill, and install the FPL provided conduit, and FPL agrees, a credit will be applied towards the contribution amount.

The charges for underground service are based upon arrangements that will permit serving the subdivision's underground distribution system from overhead feeder mains. If feeder mains are deemed necessary by FPL to provide and/or maintain adequate service and are required to be installed underground by the Applicant or a governmental agency, the Applicant shall pay FPL the difference between the cost of such underground feeder mains and the cost of equivalent overhead feeder mains.

Tariff charges for underground service to new residential subdivisions are based on timely and reasonably full use of the land being developed. Where FPL is required to construct underground facilities through a section or sections of the development where full use of facilities, as determined by FPL, may not be realized for at least two years, FPL may require a deposit before construction commences. This deposit, to guarantee performance, will be based on the estimated **total** cost of such facilities. The amount of the deposit, without interest, in excess of any differential charges for underground service will be returned to the applicant on a pro rata basis at quarterly intervals on the basis of utilization. Any portion remaining unrefunded after five years from the date FPL is first ready to render service from the extension will be retained by FPL.



Electric Service Standards

DATE
07-07-11

PREPARED BY
Distribution Construction Processes

SUBJECT
III. SERVICE PROVISIONS

SECTION: PAGE
III: 4 of 11

2. Underground Service from an Overhead System to New Residential Buildings (Less than 5 units per building)

FPL will normally provide the trench and backfill, and provide and install the PVC conduit and service lateral conductors. The Customer will provide and install the service entrance conduit (downpipe), provide and install the meter socket and the wiring from the meter socket to the service entrance equipment (**Fig. IV-11a,b**). If the Customer requests to trench and backfill, and install the FPL provided conduit, and FPL agrees, a credit will be applied towards the CIAC amount.

If the customer prefers to install, own, and maintain the underground service lateral, FPL will install a handhole at the base of the pole, at the charge specified in the tariff. Customer risers are not permitted to be attached to FPL or telephone company poles.

3. Replacement of Existing Overhead and Underground Residential Service Laterals

If a residential customer wishes to replace an existing FPL overhead service drop with an underground service lateral, or to relocate an existing FPL underground service lateral, or to replace a customer owned underground service lateral, FPL will provide the underground service lateral according to the terms, provisions, and charges specified in the tariff.

The Customer shall provide the trench and backfill, install the FPL provided PVC, and provide all restoration. The trench shall be deep enough to provide 24" of cover (36" maximum) over FPL's service lateral. The customer shall also provide and install the downpipe from the meter socket, replace the meter socket if necessary, and perform all rework necessary to accommodate the new service lateral (**Fig. IV-11a,b**). If requested by the Customer, and FPL approves, FPL may provide the trench and backfill and install the conduit, but the Customer shall pay for this work based on a specific cost estimate. In either case, FPL will provide, install, and connect the service lateral cable from the secondary source to the meter socket.

4. Mobile Home and Recreational Vehicle (RV) Parks

Individual electric metering by the utility is required for each separate occupancy unit (where the intent is to establish permanent residency) in trailer, mobile home and recreational vehicle (RV) parks for which construction was commenced after January 1, 1981.

FPL will supply service to these individual units provided the service entrances are properly wired and grounded in accordance with the National Electrical Code and local building codes, and the wiring is approved by the local inspector.

Overhead service typically requires no CIAC provided the estimated revenue supports the estimated cost of any extension that might be required (**section III.C**). Underground service requires CIAC in accordance with FPL's Tariff.

FPL's overhead service drop or buried service lateral may not terminate directly on a mobile home or recreational vehicle, but shall run to a pole or pedestal mounted service entrance provided by the Customer. The customer's service equipment is to be mounted on the load side of the meter socket. The wiring from the pole or pedestal to the Mobile Home or RV is also provided and installed by the customer.

For overhead service, a treated pole or equivalent shall be furnished to provide adequate support and elevation for FPL's service drop. Overhead service drops shall have 16 feet of clearance crossing over areas subject to mobile home or recreational vehicle movement. Other clearances are specified in **section IV.B** and **Fig. IV-5**.



Electric Service Standards

DATE
07-07-11

PREPARED BY

SUBJECT

SECTION: PAGE

Distribution Construction Processes

III. SERVICE PROVISIONS

III: 5 of 11

If service is underground, an approved pedestal shall be furnished to support and protect FPL's cable and meter (**Fig. IV-13a,b,c**). If the Customer wishes to furnish and use a pedestal which combines the service equipment and the meter socket, he may do so only if he uses equipment on FPL's approved list. It shall be the Customer's responsibility to obtain authorization from FPL before any commitments are made to use this equipment at a particular location. There will be no charge to FPL.

Where individual electric metering is required, it is often advantageous for the Customer to group multiple meter sockets and service equipment on a single pole or pedestal (**Fig. IV-13c**). Where overhead service is provided, this is aesthetically advantageous in that the number of aerial service drops is minimized. Where underground service is provided, this reduces the CIAC amount required by FPL.

In those parks or areas of parks designated for overnight occupancy (where the intended use is not for purposes of permanent residency), individual electric metering is not required, nor provided by FPL. In these cases, electric consumption is considered commercial use, and FPL will provide a single point of service (or multiple points if deemed necessary or appropriate by FPL) with each point individually metered. Electric wiring from these points to the individual units is the responsibility of the Customer.

5. Multiple Occupancy Buildings (5 Units or more per building)

For new residential multiple occupancy buildings (five or more dwelling units), the Customer may request underground service. FPL will provide underground facilities at or near the building at no cost to the Customer provided FPL is allowed to build its distribution facilities in the most economic and efficient manner. If FPL determines a padmounted transformer is necessary, the transformer will be the point of delivery, to which point the Customer will install (and FPL will connect) his cables. The customer will furnish the transformer pad location per FPL pad specifications (**section V.A**). The location will typically lie between FPL's source of power and the portion of the building closest to the available source.

Should a point of delivery not preferred by FPL be desired by the Customer, a CIAC will be required to cover any additional cost that might be incurred. Should the Customer provide the suitable location but FPL elects to place its transformer equipment elsewhere, FPL may elect to install its buried secondary conductors to an FPL owned handhole. In this case, the handhole would be the point of delivery.

The Customer shall extend his building service to FPL's designated point of delivery regardless of the distance from Customer's switchgear.

When feeder mains on tracts of land upon which multiple occupancy buildings will be constructed are deemed necessary by FPL to provide and/or maintain adequate service, and underground installation is requested by the Customer or required by a governmental agency, the Customer shall contribute the difference between the cost of underground and the cost of overhead feeder mains. There will typically be no contribution required from the Customer with respect to construction of underground distribution facilities to multiple occupancy dwellings other than feeder mains as long as FPL is free to construct such extensions in the most economic manner, and reasonable full use is made of the tract of land upon which the multiple-occupancy residential buildings will be constructed. Other conditions may require special considerations or arrangements.



Electric Service Standards

DATE
07-07-11

PREPARED BY
Distribution Construction
Processes

SUBJECT
III. SERVICE PROVISIONS

SECTION: PAGE
III: 6 of 11

6. High-Rise Residential Buildings

General - Standard service to high rise residential buildings is from a single main vault provided by the Customer, at ground level. The Customer may request that primary service be extended vertically to transformer vaults located at intervals in the building. This "stacked" vault option is available only if certain criteria are met, FPL agrees, and local codes and inspecting authorities allow this type of construction.

Economic considerations to FPL and the Customer are key factors in deciding whether to use stacked vaults. If stacked vaults are requested, and FPL approves, the Customer will be required to contribute the differential cost. That cost is the difference between the estimated cost of a single main vault and the estimated cost of the multiple vaults.

Criteria for Vaults:

- The load must exceed the following capability or CIAC will apply:
 - 1000 KVA for 120/208V loop or radial type padmounted transformers

Criteria for Stacked Vaults:

- The residential units shall be individually metered
- Service to the residential units is 120/240 volt, 3 wire
- All three phase load shall be served from a main ground floor vault
- At least 3 stacked vaults shall be required, as determined by FPL, to serve the load
- The Customer shall adhere strictly to FPL's specifications concerning vault and duct construction ([section V.C](#))

The Main Vault - The same specifications that apply to any other grade level vault apply also to the main vault of a high-rise, stacked vault distribution system ([section V.B](#)). FPL will furnish separate specifications for the main vault.

Agreement to Proceed - The Customer shall secure agreement from FPL on the use of stacked vaults in the early design stages. When this agreement has been reached, the vaults should be physically located near the center of the load they will serve.

The Customer shall obtain engineering information from FPL as to how much space will be needed for FPL's electrical equipment. The Customer should obtain FPL's detailed vault specifications before completion of the design stage.

E. Commercial Service (under 600v)

For commercial Customers whose load is such that, if located in an overhead area it could be served by one (or bank of) single phase aerial transformer(s) rated 100 kVA or less (as determined by FPL), standard service is considered by FPL to be overhead (with wood poles), at the standard voltages specified in [section III.A](#), to the FPL designated point of delivery.

Commercial Underground Service

For loads where overhead service is considered standard by FPL, and underground service is either requested by the customer or required by local governmental agency, a CIAC equal to the difference between the estimated cost of underground and the estimated cost of overhead will be required. These differential charges are specified in FPL's Underground Commercial Distribution Tariff, **providing the service requested is at the standard voltage, in the opinion of FPL, for the load being served.** Special situations or requests for non-standard voltage may require specific cost estimates. Where EAR does not support the estimated cost of an FPL line extension, additional CIAC will be required ([section III.C](#)).



Electric Service Standards

DATE
07-07-11

PREPARED BY

SUBJECT

SECTION: PAGE

Distribution Construction Processes

III. SERVICE PROVISIONS

III: 7 of 11

a. Underground Service to Small Commercial Loads

In overhead areas where the meter socket is located at least 5 feet but not more than 100 feet from the utility pole, and where the Customer's main line switch is no more than 60 Amps for a two-wire 120 volt or 125 Amps for a three-wire 120/240 volt service, FPL will install the underground service to the meter socket if the Customer prefers (typically, this is the only situation FPL will install underground service conductor to a commercial Customer's meter socket, unless otherwise mutually advantageous to both the Customer and FPL). A CIAC is required. The Customer provides the trench and backfill (24" minimum cover); the 2" PVC conduit from the meter socket (see Fig. IV-11a,b) to the base of the pole (24" radius 90° 2" PVC bend at base of pole); all restoration, easements and permits.

Otherwise, the customer can install his underground service conductors to an FPL handhole at the base of the pole (where FPL will connect its conductors to the Customer's), where CIAC also applies; or, the customer can elect to receive overhead service. **Customer owned risers for commercial electric service are not permitted on FPL or Telephone Co. poles.**

Where FPL's secondary source is "underground" (i.e. vault, padmounted transformer, or handhole), the customer provides and installs the service conductors, and FPL connects those conductors at that secondary source. If that underground secondary source was existing before the request for service, no CIAC would typically be required.

b. Underground Service to Moderate Commercial Loads

In overhead areas where, in the opinion of FPL, the load is such that secondary voltage can be provided at an overhead source, FPL will provide secondary conductors to a handhole at the base of the pole where FPL will connect to the Customer's underground conductors. If a transformer (or transformers) must be hung to make this secondary voltage available, FPL will consider installing underground primary cable to a padmounted transformer, where FPL will connect to the Customer's underground conductors. In either case, CIAC applies.

If either of these options are not desirable, the customer can elect to receive overhead service. **Customer owned risers for commercial electric service are not permitted on FPL or Telephone Co. poles.**

Where FPL's secondary source is "underground" (i.e. vault, padmounted transformer, or handhole), the customer provides and installs the service conductors, and FPL connects those conductors at the secondary source. If that underground secondary source was existing before the request for service, no CIAC would typically be required.

c. Underground Service to Large Commercial Loads

If the load is such that, if located in an overhead area it could **not** be served by one (or bank of) single phase aerial transformer(s) rated 100 kVA or less, in the opinion of FPL, FPL's standard service then would consist of underground primary cables (from an overhead source determined by FPL) to a radial padmounted transformer. CIAC would typically not be required if the cost of an equivalent overhead line extension is justified (**section III.C**), but would be required for cases including, but not limited to; radials that cannot originate from an overhead source where, for instance, a pad mounted switch cabinet must be installed; "loop" systems; underground primary conductors that do not originate at an overhead source at FPL's preferred location; points of delivery requested beyond those designated by FPL; etc.

For larger loads exceeding 2500 KVA and other special circumstances, FPL's standard service consists of underground primary cables from an overhead source (determined by FPL) to a radial vault. The CIAC provisions stated in the preceding paragraph apply to vaults, as well. For padmounted transformer and vault specifications, refer to **section V**.



Electric Service Standards

DATE
07-07-11

PREPARED BY
Distribution Construction Processes

SUBJECT
III. SERVICE PROVISIONS

SECTION: PAGE
III: 8 of 11

d. Automatic Throwover Facilities to Large Commercial Loads

Throwover facilities enable a customer's primary electrical feed to be switched from a preferred source to an emergency source, using automatic FPL switching equipment. Throwover facilities are provided at no charge only in FPL designated underground areas where for physical, operating, or economic reasons, an underground throwover system is in the collective best interest of FPL and its customers.

In non-designated underground areas, throwover facilities *may* be provided, although CIAC would apply. If a throwover system is feasible, the CIAC would include, but not be limited to, the estimated cost of all additional equipment required for operation of the throwover system and the estimated cost of the additional emergency feeder to the customer's location. New installations with a demand load of at least 500 KVA will be granted a credit, not to exceed the amount of CIAC required, equal to their first year's annual base rate revenue. Existing customers increasing their demand load at least 500 KVA will be granted a credit, not to exceed the amount of CIAC required, equal to their first year's annual base rate revenue.

The type of throwover system equipment to be installed (ATS Powell-Esco vs. Vac-Pac) is the decision of FPL. If the customer specifically requests a more expensive option than required for the load being served, the additional cost is borne as CIAC.

For additional information concerning throwover service, contact you local construction representative.

e. Loop service to Large Commercial Loads

Loop service can be provided in lieu of throwover based on the criteria stated in section (d) above. Loop service may be more economical when there is only one feeder (source) available.

Examples of Loop:

Some typical examples of loop service include but are not limited to, strip shopping centers, building supply chains, grocery stores, large hotels, outdoor malls, etc.

For additional information concerning loop service, contact you local construction representative.

F. Underground Service Connections in the City of Miami Network Area

Service voltage in the City of Miami Downtown Network Grid is four wire, three phase wye, 120/208 volts. When other voltages are desired, the Customer is requested to contact FPL to determine their availability. Network service is only available from the existing network grid, new secondary networks are not being constructed.

Service may be available from the underground street secondary mains, or from a vault, depending on the magnitude of the load involved.

For service from the secondary mains, the Customer will provide and install, at the Customer's expense, the conduit and cables from the Customer's main switch or FPL's metering devices to the point of delivery. The point of delivery will be FPL's manhole, pullbox or vault located at or near the property line, as designated by FPL. FPL will connect the Customer's secondary cable to FPL's facilities.

FPL may, where it is mutually advantageous, elect to extend primary circuits into the Customer's property and serve the immediate and adjoining premises from a standard (non-networked) transformer vault located on the Customer's property. See [Section V](#).



Electric Service Standards

DATE
07-07-11

PREPARED BY

SUBJECT

SECTION: PAGE

Distribution Construction Processes

III. SERVICE PROVISIONS

III: 9 of 11

G. Temporary/Construction Service

1. General

Temporary/construction service is usually a limited term service to installations such as fairs, exhibitions, construction projects, displays and similar projects. Contact FPL regarding availability and applicable installation and removal charges before installing the temporary facility. These nonrefundable charges are paid **in advance** of FPL's construction.

Where the Customer's service entrance cable does not exceed 200 ampere capacity, the nonrefundable flat charge is specified in FPL's Tariff (Sheet No. 4.030). Larger services may require additional charges. For overhead service, the charge covers installation and removal of an overhead service and meter, at an existing secondary source. For an underground service, the charge covers connecting and disconnecting the Customer's service cable to FPL's existing underground facilities, including installation and removal of the meter. Contact FPL to determine current charges and availability of temporary/construction service.

Service may be single phase or three phase, 60 hertz, at the available standard secondary distribution voltage. This service is available only when FPL has existing capacity in lines, transformers and other equipment at the requested point of delivery.

For overhead temporary service, the Customer shall provide a sturdy and adequate service drop support, complete with service entrance and FPL approved meter enclosure, to accommodate FPL's service drop and meter (**Fig. IV-1**). In an underground area, a pedestal with FPL approved meter socket shall be provided to accommodate the meter, and the Customer's service cable shall be installed up to FPL's facilities (**Fig. IV-2**). An adequate amount of service cable shall be left available for FPL crews to pull into the handhole or transformer for connection. **Note: In underground residential distribution (URD) areas, handholes will not be installed by FPL for the sole purpose of providing temporary service.**

If specific electrical service other than that stated above is required, FPL, at the Customer's request, will determine its feasibility and may provide such service based on the estimated cost of installing and removing such additional electrical equipment. This estimated cost is payable in advance to FPL and will be subject to adjustment or refund based on the actual costs. The additional service may be overhead or underground, depending on circumstances at the particular location, as determined by FPL.

All temporary/construction services shall be subject to all of the applicable Rules, Regulations and Tariff charges of FPL, including service charges. The energy used by the temporary service will be billed monthly under the appropriate rate schedule applicable to commercial and industrial type installations.

The Customer's installation shall satisfy all the requirements of the National Electrical Code and other authorities having jurisdiction.

2. Reduced Cost Alternatives

a. TOP

The TOP (temporary overhead permanent) alternative is available for residential and small commercial customers where the permanent FPL approved meter socket, meter, and weatherhead are configured such that they can be used for temporary service. Upon receipt of the temporary inspection, FPL installs the permanent service to the meter socket, and this service is used for construction purposes until the Certificate of Occupancy is obtained. Since no additional work is required by FPL for this type service, no additional construction charges are



Electric Service Standards

DATE
07-07-11

PREPARED BY
Distribution Construction Processes

SUBJECT
III. SERVICE PROVISIONS

SECTION: PAGE
III: 10 of 11

required, provided that all of the FPL construction work can be performed in a single field visit. However, **check with your local authorities first**. Not all inspectors allow this alternative.

b. TUG

The TUG (temporary underground) alternative is available for underground residential services where the permanent FPL approved meter socket, meter, and downpipe are configured such that they can be used for temporary service. Upon receipt of the temporary inspection, FPL installs the permanent service to the meter socket, and this service is used for construction purposes until the Certificate of Occupancy is obtained. Since no additional work is required by FPL for this type service, no additional construction charges (other than the cost of the permanent underground service itself) are required, provided that all of the FPL construction work can be performed in a single field visit. However, **check with your local authorities first**. Not all inspectors allow this alternative.

One variation of the TUG involves building a portion of the permanent wall and mounting the permanent meter socket, down pipe and customer switch panel on it. The main line switch and breakers for a 120V duplex GFCI receptacle and a 50A 230V receptacle are mounted in the panel with the receptacles mounted below the panel. A minimum 6 mil clear plastic sheet is mounted over the panel to protect it from the weather and a sticker warning of live electrical is placed on the panel. Upon receipt of the Customer's contribution for the permanent underground service, the application for service and the inspection, FPL will install the permanent underground service and meter, and the receptacles mentioned above are used for construction power.

H. Unauthorized Connections & Disconnections

All connections of the Customer's wiring to that of FPL, all disconnects of service entrance conductors, all meter removals and installations and all breaking of FPL meter equipment seals shall be made only by FPL, except as allowed in **Section III.I** of these standards.

Any other connection or disconnection of FPL's service by the Customer or his agent is prohibited. If done with the intent to injure or defraud, it is punishable by law. Violators will be prosecuted.

I. Change in Service Requirements (Service Changes)

The Customer will normally own all the service facilities on his side of the point of delivery; i.e., the point where FPL's wires carrying the voltage of supply are to join the Customer's wires, except for the meters which will be owned by FPL.

The Customer shall notify FPL, in advance, when a change in service (service change) is being considered to accommodate provisions that service and metering facilities remain adequate.

When a service change requires disconnection of FPL's service, the customer shall request a disconnect/reconnect from FPL. The Customer shall establish an advance appointment to ensure proper coordination between his electrical contractor and FPL crews who will disconnect the service and later reconnect after an inspection (when required by local authorities) is received.

Exception:

FPL normally performs both the disconnect and reconnect. In certain cases however, the Customer's **licensed and qualified electrical contractor** is allowed, **at his option, but only when approved by FPL**, to perform the **disconnect** on **overhead services only**, when the following criteria are met:



Electric Service Standards

DATE
07-07-11

PREPARED BY

SUBJECT

SECTION: PAGE

Distribution Construction Processes

III. SERVICE PROVISIONS

III: 11 of 11

- The Customer **shall** be a residential or small commercial facility with a main line switch rating of 300 Amps or less, served by an FPL single phase overhead service. **No three phase service shall be disconnected by an electrical contractor.** FPL must disconnect all three phase services to ensure that proper phase rotation is maintained.
- FPL service attachment point at the building or structure **shall** remain intact. No service shall be removed from the attachment point or the attachment point altered in any way.
- The meter socket(s) **must not** have an FPL locking device installed.
- If multiple meters are involved, the electrician **shall** "mark" each meter **and** socket.
- **Only a licensed and qualified electrical contractor** may perform the disconnect function and he **shall** schedule a reconnect date (appointment) with FPL **before** disconnecting the service. If the appointment is not made before the disconnect, FPL will not be responsible for a same day reconnect.
- The service **shall** be cut on the **load side** of FPL's connection to the customer's service conductors. **No FPL conductors are to be cut.**
- The service **shall** be disconnected before removing the meter(s). **No meter is to be removed from an energized meter socket.**
- FPL personnel only are to perform the reconnect and only after an inspection (if required by the local authority) is received. **Electrical contractors are not allowed to reconnect the service.**
- The decision to perform this type of disconnect is entirely voluntary for the electrical contractor and allows work to commence without having to wait for FPL to disconnect the service. However, the electrical contractor still has the option of FPL performing the disconnect if he prefers.

J. Service to Special Equipment

The operation of electric furnaces, electric dredges and draglines, large motors and other heavy utilization equipment, if served from FPL's distribution system, might interfere with service to other Customers. Contact FPL concerning the requirements for furnishing this type of service. Refer to [Section IX](#).

K. Service to Boat Facilities

FPL electric service to marinas and private docks will be to a designated point of delivery on shore. The Customer shall bring his service conductors to the point of delivery (such as a handhole, pedestal, junction box, or padmounted transformer). FPL will not extend its conductors onto marinas or docks.

The Customer should install his FPL-approved meter sockets so as not to be a hazard to people on the dock and they shall be accessible for meter maintenance and monthly readings. The socket shall be mounted such that the meter will face the dock and not the open water and not represent a protrusion hazard.

L. 2 wire, 480V Metered Service

On all self-contained, metered installations (320 amperes or less) where the service voltage is 480V to ground (2 wire), a non-automatic disconnect device shall be provided and installed by the Customer on the **line side** of each individual meter. For meter centers, there shall be one disconnect device on the **line side** of each meter. The disconnect device shall be lockable or sealable by FPL and adjacent to each meter. The Customer-owned non-automatic (no over current protection) disconnect device ampacity must meet all NEC Guidelines. A bypass equipped meter enclosure is required and shall be selected from the Approved Meter Equipment Enclosure List.



Electric Service Standards

DATE
07-13-11

PREPARED BY

SUBJECT

SECTION: PAGE

Distribution Construction Processes

IV. SERVICE and METER CONNECTIONS

IV: 1 of 24

IV. SERVICE and METER CONNECTIONS

A. Service Equipment

1. General

The Customer should consult FPL at an early stage to verify availability of service ([section II.C](#)) and to determine the FPL designated point of delivery ([section III.B](#)). Contact with FPL should be made before the purchase of equipment and its installation. This FPL approval is not a substitute for inspection and approval by the local electrical inspection authority. FPL assumes no responsibility for the Customer's wiring installation. Upon request, FPL will inform the Customer of available short circuit currents.

The Customer shall provide, install, own, and maintain all service entrance conductors, service equipment, and metering equipment cabinets ([section VI](#)). The service equipment usually consists of a circuit breaker or switch and fuses, and their accessories, located near the point of entrance of the supply conductors to the buildings or otherwise defined area. It is intended to be the main control and means of cutoff of the supply.

FPL will provide, install, own and maintain adequate meters to measure the electrical quantities required to apply its rate schedules and contracts.

The Customer may choose the type of service equipment he prefers, consistent with local building codes and the National Electrical Code (NEC). It shall be able to successfully interrupt the maximum fault current available at its location. Where load growth is possible, FPL recommends that the capacity of service entrance conductors and service equipment be greater than the minimum requirements of the NEC or other local codes. FPL encourages residential Customers to install a service entrance with a capacity of at least 150 amperes for average homes and more in the case of larger homes.

Service entrance equipment shall be in a location which is accessible and not likely to become obstructed.

Meters shall not be located in the median of divided roads or highways.

The customer's service conductors shall be continuous from the point of delivery to the metering equipment. If splice boxes, pull boxes, troughs, or other such items are located in the service run, they shall provide a means of sealing by FPL with standard company meter seals.

The customer's service conductors shall be marked (tagged) at the source with the location served. See [Fig. IV-14](#) for tagging details.

No fuses should be installed at any point in the grounded neutral conductor of the service entrance.

No resistor or reactor or other similar fault current limiting device shall be installed in the neutral or the phase conductors of the service entrance without the approval of FPL.

Where customer owned stepdown transformers are required they will be installed on the load side of the meters.

Where permitted by applicable codes, the service equipment will be on the load side of the meters except that if the service is fed from the City of Miami Downtown Network Grid, the service equipment will precede the meter.

A main disconnecting switch may be ahead of the meters when more than six meters are grouped ([Fig. IV-12b](#)). This is because the NEC requires a main disconnect switch where it would otherwise be necessary to operate more than six switches to completely disconnect the building service.



Electric Service Standards

DATE
07-13-11

PREPARED BY

SUBJECT

SECTION: PAGE

Distribution Construction Processes

IV. SERVICE and METER CONNECTIONS

IV: 2 of 24

When installed ahead of the meters, the door of the main switch shall be sealable in both the "on" and "off" positions. The handle shall be sealable in the "off" position.

A minimum *horizontal* separation of 3' shall be maintained between natural gas service equipment (*vented regulators*) and electric metering or termination equipment. Transformers shall have a minimum separation of 5' from natural gas service equipment. A minimum separation of 5' shall be maintained between electric metering or termination equipment and liquid petroleum facilities on site but not filled on site. If the liquid petroleum facilities are filled on site the minimum separation is 10'.

All commercial installations and all residential three phase installations must contain lever bypass, jaw tension/release socket blocks with the exception of small (120V or 120/240V, with 100 amp meter enclosure), **non-critical** loads such as:

- Lighted signs and billboards
- Temporary construction poles and service to construction trailers
- Irrigation pumps
- Residential detached garages
- Gate openers
- Barns
- Apartment / Condo house meters
- Bus stops
- Street lighting

The use of a Metallic fishtape to pull service conductors into FPL owned equipment is not allowed.

2. Ampere Rating

a. Residential

The rating of the service entrance equipment shall satisfy the general requirements stated above, the NEC and local building codes. Section 230 of the NEC states that the minimum rating for a one family dwelling with six or more two-wire branch circuits, or an initial computed load of 10 kVA or more is 100 ampere, three-wire. For dwelling units with less load, as computed in accordance with NEC guidelines, the minimum may be 60 ampere, three wire if approved by the inspecting authority. In very special cases where the load is only one or two two-wire branch circuits, the service disconnecting means may have a rating of no less than 15 amperes or 30 amperes, respectively, if approved by the inspecting authority.

As stated previously, FPL recommends that the service entrance have more capacity than the minimum required by the NEC. Local inspecting authorities shall be consulted, since some locations may have requirements that exceed the minimums.

b. Commercial

The rating of the service equipment for commercial or industrial occupancies will depend on the connected load, and in most cases, will be specified by the Customer's engineer.



Electric Service Standards

DATE
07-13-11

PREPARED BY

SUBJECT

SECTION: PAGE

Distribution Construction Processes

IV. SERVICE and METER CONNECTIONS

IV: 3 of 24

It is important that the requirements be reviewed with FPL at an early date so that a satisfactory solution as to service voltage and service entrance location can be determined. At this time, details as to the nature and size load to be served may be given to FPL, if this has not already been done.

The service equipment should be chosen to satisfy all the requirements of the Customer for the control of his load and should be consistent with the NEC, local building codes and the rules of the inspecting authority.

One requirement is that the service equipment shall be able to safely interrupt the maximum fault current available at its location. Upon request, FPL will supply information which will permit the maximum available fault current to be determined.

FPL emphasizes that changes in the Customer's load and other loads in the area may require changes in FPL's system. These changes may increase the available fault current. Allowance should be made for this possible increase.

c. Service Equipment Rated Below 600 Volts

In those cases where the Customer's ampere demand at these voltages exceeds 600 amperes, or the Customer's service entrance wire size exceeds 1-800 KCMIL or 2-500 KCMIL conductors, per phase, FPL will normally require the Customer to furnish a current transformer cabinet and an instrument transformer rated meter socket, installed ahead of his service equipment. The Customer will also furnish and install a 1 1/2 inch conduit from the cabinet to the meter socket (refer to the specifications found in [section VI](#)). FPL will provide and perform the current transformer installation, install the secondary wiring from the current transformer to the meter socket, and install the meter.

On all self-contained installations (600 amperes or less) where the service voltage is 480V to ground (2 wire), a non-automatic disconnect device shall be provided and installed by the Customer on the line side of each individual meter. The disconnect device shall be lockable or sealable by FPL and adjacent to each meter. The Customer-owned non-automatic (no over current protection) disconnect device ampacity must meet all NEC Guidelines. A lever bypass equipped meter enclosure is required and shall be selected from the Approved Meter Equipment Enclosure List.

For service disconnecting means rated 1,000 amperes or more used on a solidly grounded 277/480 volt wye service, ground-fault protection shall be provided. This may be omitted, if approved by the inspecting authority or if the service equipment controls a continuous industrial process where a non-orderly shutdown would otherwise introduce additional or increased hazards.

Where for any reason, a main disconnecting switch is required in multi-metered service installations, it will be on the line side of the meters. The door of this switch box shall be sealable. No socket or current transformer cabinet will be required ahead of this switch.

d. Service Equipment Rated Over 600 Volts

When the Customer takes service at primary voltage, he shall provide service equipment rated for the voltage supplied. The service equipment will normally be on the load side of FPL's instrument transformer metering installation.



Electric Service Standards

DATE
07-13-11

PREPARED BY

SUBJECT

SECTION: PAGE

Distribution Construction Processes

IV. SERVICE and METER CONNECTIONS

IV: 4 of 24

The service equipment shall satisfy all the requirements of the NEC, the building code, and the inspecting authority.

FPL shall be consulted so that the Customer's primary service equipment may be coordinated with FPL's feeder protection circuit breakers and fuses.

For padmounted primary metering, the customer will either provide a metering cabinet listed on FPL's approved enclosure list, or FPL will provide the metering cabinet and bill the customer the cost. For primary metering in vaults, FPL will provide, own, and maintain the metering cabinet located inside the vault.

B. Overhead Service

For residential overhead service, the attachment will normally be within ten feet of the corner, on the side of the building nearest FPL's secondary facilities (**Fig. IV-4**). The Customer's service entrance should be installed in such fashion that service drop wires will not cross over buildings, swimming pools, or adjacent property not owned by the Customer. FPL may provide the Customer with two copies of an "Electric Service and Meter Location" sketch (FPL form 1453) confirming the service location (**Fig. IV-3**).

1. Vertical Clearance to Ground

The point of attachment for service drops not exceeding 150 volts from any conductor to ground shall allow ten feet of ground clearance to lowest point of sag in the service drop.

Service drops exceeding 150 volts but less than 300 volts from any conductor to ground shall allow ten & one-half feet of ground clearance to lowest point of sag.

Where the service drop must pass over immediately adjacent driveways or parking areas subject to truck traffic or if it is within 25 feet of a swimming pool or if the voltage to ground is over 300 volts, additional clearance shall be provided. In these cases a greater attachment height shall be provided.

The required attachment height will be shown on the "Electric Service & Meter Location" sketch. It is important the Customer furnish this information to the building contractor and electrician.

2. Clearance from Building Openings

Service conductors shall have a clearance of not less than three feet from windows, doors, porches, fire escapes or similar openings.

3. Clearance from Swimming Pools

FPL prefers a minimum horizontal clearance of 10 feet from its facilities to swimming pool edges or pool enclosures. However if certain conditions are met, including minimum vertical clearances, the National Electrical Safety Code (NESC) provides for less than 10 feet of horizontal separation. Costly relocations of existing services may become necessary if the Customer builds a pool too near FPL's electric facilities. Should there be any question of conflict between the location of a new swimming pool or pool enclosure and FPL's facilities; the Customer is to contact FPL before construction of the pool facilities to ensure required NESC clearances are met.



Electric Service Standards

DATE
07-13-11

PREPARED BY

SUBJECT

SECTION: PAGE

Distribution Construction Processes

IV. SERVICE and METER CONNECTIONS

IV: 5 of 24

4. Anchorage for Overhead Service Drop Cable or Wires

The Customer shall provide a safe and adequate anchorage for FPL's overhead service drop conductors at the agreed upon location and height.

FPL will furnish, and the Customer will install, a suitable attachment for the service drop. The attachment device furnished will vary, to be compatible with the type of building construction (**Fig. IV-6a thru 6c**).

FPL WILL NOT BE RESPONSIBLE FOR DAMAGE TO THE CUSTOMER'S BUILDING OR WIRING RESULTING FROM FAILURE OF THIS ANCHORAGE.

The point of service drop attachment and its height will be shown on the "Electric Service and Meter Location" sketch. It should be sufficient to provide all the required clearances as shown in **Fig. IV-5**. The location should be accessible from the ground by a ladder.

Where the height of the building would not allow adequate clearance from service drop to ground, the Customer shall furnish and install a service mast or other approved extension (**Fig. IV-6a**). FPL will provide and install the bracket for attaching the service drop to the service mast.

5. Installation of Service Entrance

The service entrance conductors shall be provided and installed by the customer in accordance with local building codes and the latest NEC. The conductors will extend a minimum of 36 inches beyond the service weatherhead to permit connection to FPL's service drop wires. FPL limits the number of customer conductors per service to three per phase (i.e. - 3 weatherheads with one conductor per phase; or 2 weatherheads - one with parallel conductors and one with single conductors; or 1 weatherhead with three conductors per phase where allowed by code). Call your local new construction office in situations where the load exceeds the capacity of three 750 KCMIL AL or CU conductors per phase.

The service entrance weatherhead shall be above the service drop attachment. If this is impractical, the weatherhead shall not be farther than 24" from the point of attachment.

Service drop conductors and service entrance conductors will be arranged in a manner that will prevent water from getting into the service entrance raceway or cable sheath (**Fig. IV-6a**).

The neutral conductor of the service entrance shall be identified by the Customer.

Wiring of the meter socket shall be as shown in the appropriate sketch of **Fig. IV-8**.

The service entrance conduit is installed by the Customer from the service weatherhead to the meter socket or the service entrance equipment, when this precedes the meter. It may be either exposed on the exterior building wall, or concealed within the structure itself in a permanently inaccessible location. Condulets (such as LB, LL, LR) shall not be used. Where exposed to the weather, conduit shall have threaded joints and shall be arranged to drain.

In the case of the service entrance conductors for a three phase, four wire delta service, one of the ungrounded conductors will have a higher voltage to ground than the other two conductors (**Fig. IV-8**, Meter Symbol J). This conductor shall be durably and permanently marked by an outer finish that is orange in color or by other durable effective means, and landed on the right side of the meter can. This marking will ensure connection to the proper FPL conductor when the service is connected.

C. Illustrations

The following illustrations contain pertinent information regarding the installation and connection of overhead and underground services.



FIGURE IV-1

Temporary/Construction Service - from Overhead System (typical)

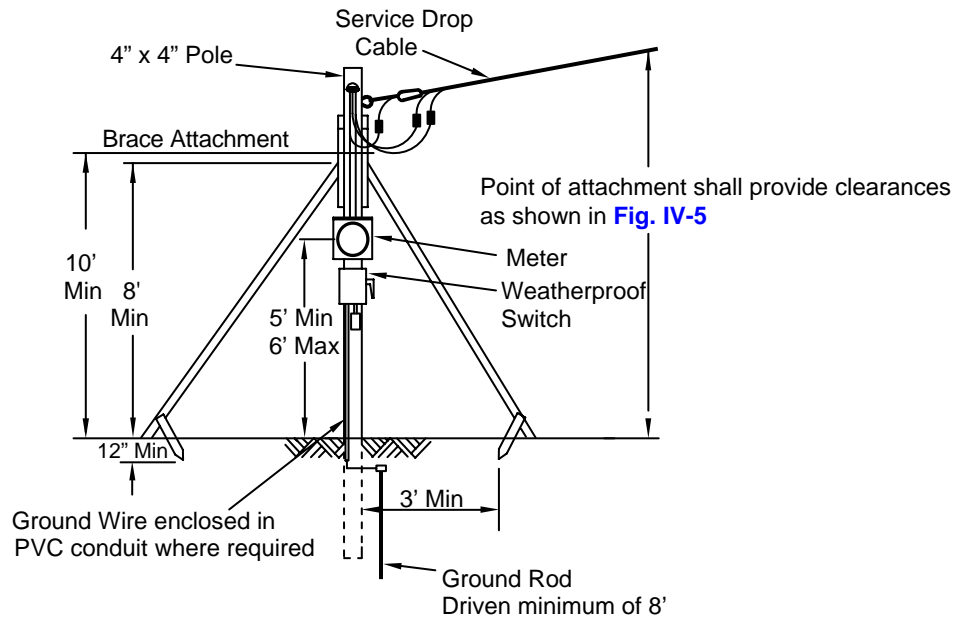
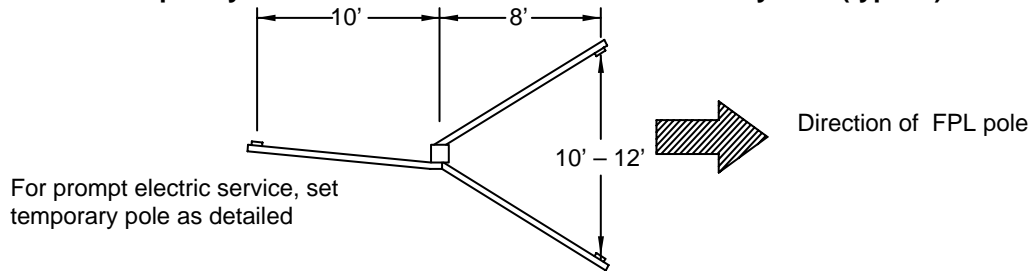

Notes:

1. Before service can be run, Company must have an electrical inspection; necessary tree trimming shall be done by the customer; and the deposit and non-refundable temporary service charge shall be paid.
2. Service pole shall not be within 25 ft. of swimming pool and must provide clearances shown in [Fig. IV-5](#).
3. Unspliced timbers are required (minimum length of 12 ft. for 2x4 braces and 16 ft. for 4x4 posts. Use ten penny nails (3" long).
4. Special arrangements shall be made with FPL if service drop exceeds 80 ft. or is larger than 200 amp capacity.
5. Minimum typical requirements are shown. If local code requirements are more stringent, they shall be adhered to.
6. The surface the meter socket is mounted on shall be plumb so the meter socket jaws are truly vertical. The meter enclosure must be on FPL's approved list.
7. Where acceptable to the inspecting authority, an 18 ft. treated pole (5" min. diameter at the top) may be substituted for the 4x4 timber and braces, provided the pole is set 5 ft. deep and well tamped. All other requirements remain the same.



FIGURE IV-2
Temporary/Construction Service - from Underground System (typical)

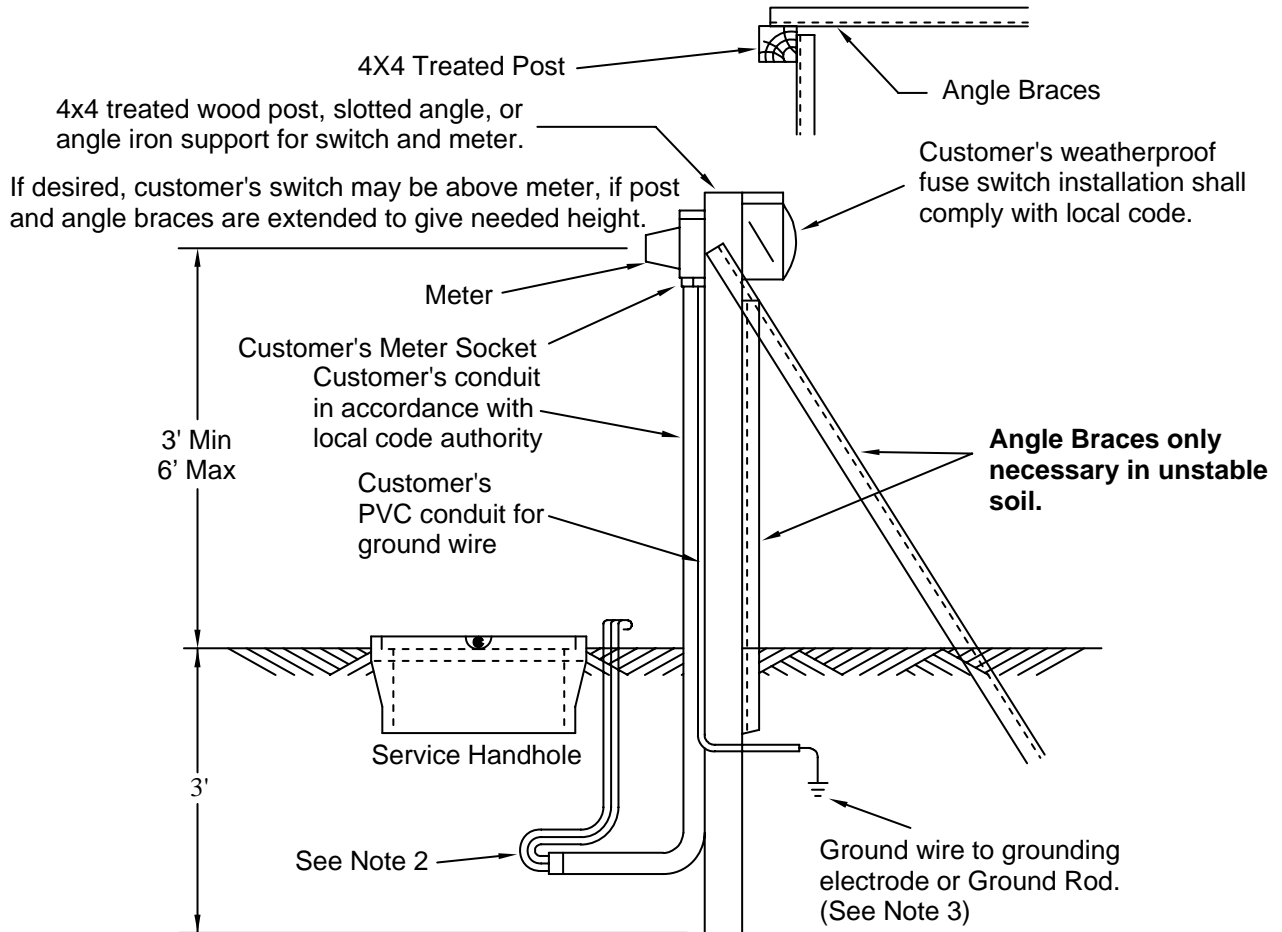

Notes:

1. Before service can be connected, the company must have the electrical inspection; necessary grading shall be done by the customer; and the deposit and non-refundable temporary service charge shall be paid. Contact the FPL representative for availability and location.
2. The customer shall leave a five foot length of service conductor above ground, outside of source, for connection to FPL secondary by FPL.
3. Temporary service should be located outside the utility easement to avoid driving the ground rod into any existing underground cables.
4. Service Conductors shall be near secondary side of the transformer.
5. The meter enclosure must be on FPL's approved list.

Padmounted Transformer

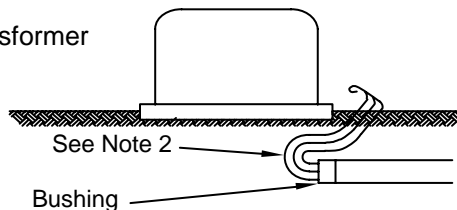



FPL

Electric Service Standards

DATE

07-13-11

PREPARED BY

SUBJECT

SECTION: PAGE

Distribution Construction Processes

IV. SERVICE and METER CONNECTIONS

IV: 8 of 24

FIGURE IV-3

FPL Electric Service and Meter Socket Requirements Form

APPLICANT _____ Current FPL Account No. _____

MAILING ADDRESS _____ CITY, ZIP CODE _____

SERVICE ADDRESS/LEGAL DESCRIPTION _____

PHONE (WEEKDAYS) _____ DATE _____

FPL is pleased to advise that electric service for your proposed _____ will be available from our Distribution facilities as shown on the sketch below. We understand you are requesting ___Overhead ___Underground, ___ volts, ___ phase service. The items checked below and receipt by our representative of the white copy of this form with your signature acknowledging your receipt, are required **before** FPL provides electric service:

Payment: _____ Construction/Temporary Service Charge:	\$ _____
(Check or _____ Security Deposit for Construction/Temporary Service:	\$ _____
Money Order) _____ Underground/Overhead Differential Charge for Permanent Service:	\$ _____
_____ Line Extension Contribution In Aid of Construction (CIAC):	\$ _____
Total:	\$ _____

_____ Tree Trimming & Clearing: _____ Feet	_____ Site Plan _____ Electrical Load Information/Plans
_____ Each Side of Proposed Line	_____ Easement for FPL Facilities/Legal Description of Property
_____ Installation of Meter Socket & Downpipe/ Weatherhead according to FPL Specifications	_____ Contact FPL _____ days before Certificate of Occupancy concerning Application/Security Deposit for permanent service.
(see checklist on reverse side of this sheet)	_____ Final City/County Electrical Inspection
_____ Install eyebolt (for FPL to attach wires to)	_____ \$ _____ Security Deposit _____ is required before _____ will be billed after permanent service provided. _____ Other:
_____ Configuration _ Meter Socket*	

*Meter socket must be approved for use in FPL service area. Current list of **approved** sockets available upon request. Socket configurations are shown on reverse side of this form.

For overhead service, minimum attachment height is to be 12 feet above grade. For underground service, minimum cover is to be 24 inches (maximum 36 inches). FPL specifications and requirements must be adhered to and are available upon request. Upon timely completion of the above required items and agreement between you and our Representative, service may be provided approximately the week of _____ or as mutually agreed upon. Changes to type service requested, failure to comply with above requirements, or delays to FPL's construction schedule may affect proposed date of service.

"SERVICE LOCATION SKETCH"

INDICATE NORTH

PLEASE SIGN ON THE LINE PROVIDED BELOW, RETAIN A COPY AND RETURN A COPY TO FPL.

RECEIPT IS HEREBY ACKNOWLEDGED:

MAKE INQUIRIES TO:

APPLICANT _____ DATE _____

TITLE (IF CORPORATION)

BY (OTHER THAN APPLICANT)



FIGURE IV-4
Guide for Locating Point of Delivery on Outside of Building

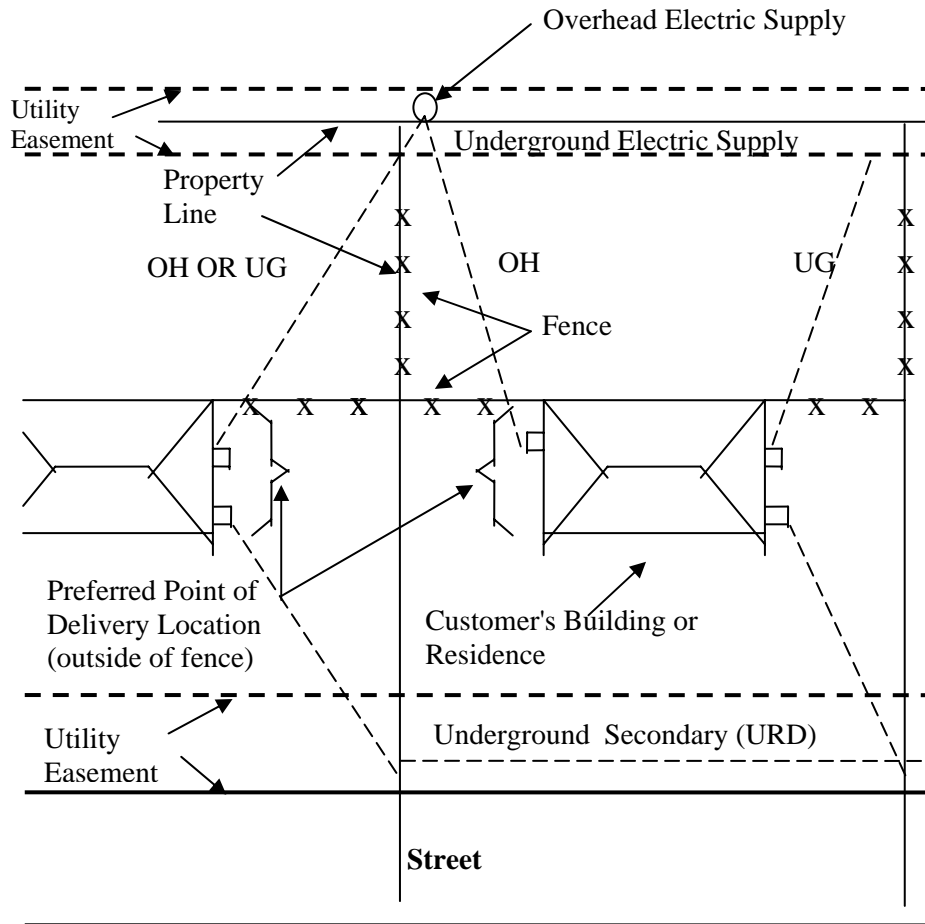

NOTES:

1. Customer arranges for approval of Point of delivery by FPL.
2. Customer provides, without cost to FPL, suitable space on his premises for the installation of FPL's metering and service facilities.
3. Customer provides easements for FPL's conductors and equipment at no cost.
4. Any FPL-approved change from originally approved Point of Delivery will be in accordance with a customer contribution based on any added cost to reach the new point of delivery.



FPL

Electric Service Standards

DATE

07-13-11

PREPARED BY

SUBJECT

SECTION: PAGE

Distribution Construction Processes

IV. SERVICE and METER CONNECTIONS

IV: 10 of 24

FIGURE IV-5 Overhead Service - Minimum Vertical Clearances

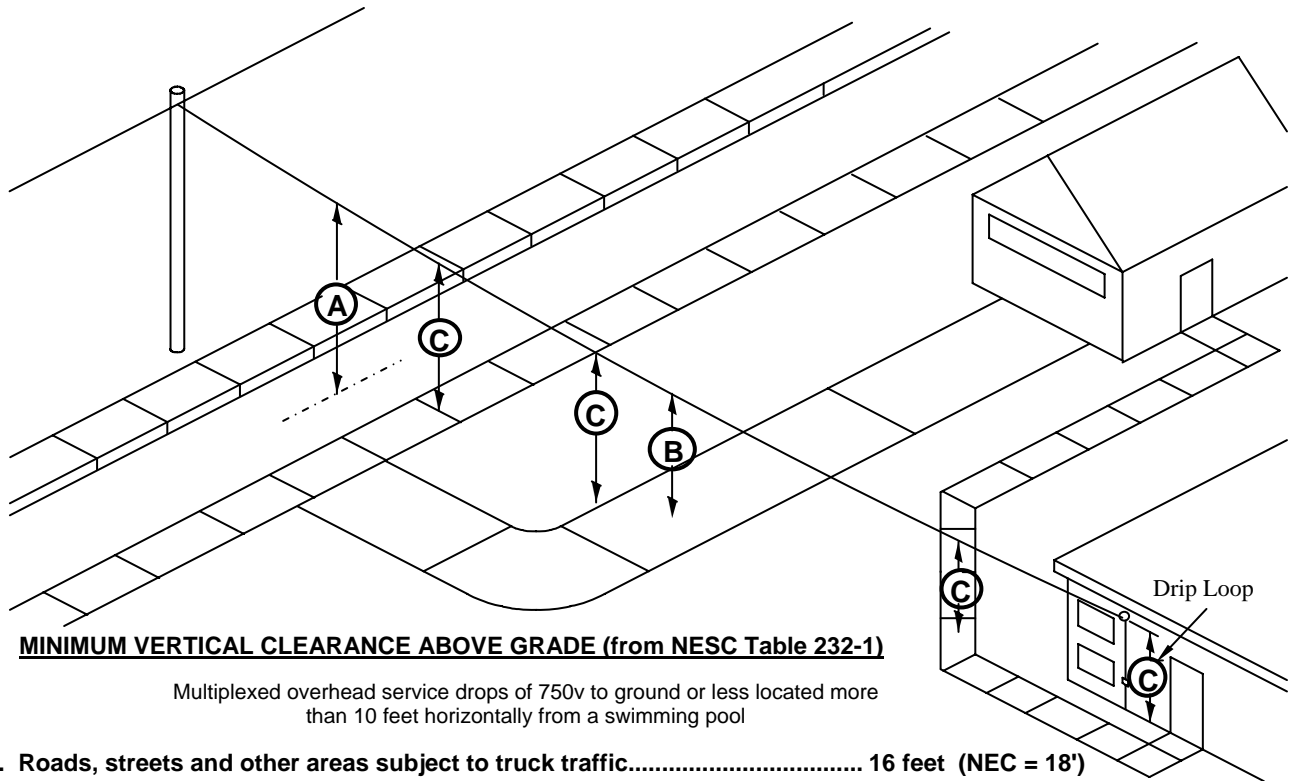

MINIMUM VERTICAL CLEARANCE ABOVE GRADE (from NESC Table 232-1)

Multiplexed overhead service drops of 750v to ground or less located more than 10 feet horizontally from a swimming pool

- A. Roads, streets and other areas subject to truck traffic..... 16 feet (NEC = 18')**
- B. Driveways, parking lots and alleys 15 feet (NEC = 18')**
 Exception - Residential driveways only where attachment height at building does not permit 15 feet of clearance:
 - Voltage limited to 300v to ground:
 - Service Drops12.5 feet (NEC = 12')
 - Drip Loops.....10.5 feet (NEC = 12')
 - Voltage limited to 150v to ground:
 - Service Drops12 feet (NEC = 12')
 - Drip Loops.....10 feet (NEC = 12')
- C. Spaces and ways subject to pedestrian or restricted traffic only..... 12 feet (NEC = 12')**
 Exception - Where attachment height at building does not permit 12 feet of clearance:
 - Voltage limited to 300v to ground:
 - Service drops and drip loops10.5 feet (NEC = 12')
 - Voltage limited to 150v to ground:
 - Service drops and drip loops10 feet (NEC = 10')
- D. Other land (such as cultivated, grazing, forest, orchard, etc.) traversed by Vehicles..... 16 feet (NEC = 18')**

NOTES: -120v single phase, 120/240v single phase, and 120/208v wye 3 phase services meet the 150v to ground criteria.
 -120/240v open or closed delta 3 phase and 277/480v wye 3 phase services meet the 300v to ground criteria.
 -240/480v delta services do not meet either the 150v or 300v to ground criteria and do not qualify for the exception to the basic clearance.

The clearances above are NESC minimum values for worst-case sag conditions. The attachment height at the building or customer's service pole must be sufficient to provide these clearances for all situations involved. Good judgment dictates that initial installation be made at higher values to ensure code compliance under worst-case sag conditions. For additional details and clarification regarding these and all clearances, refer to Section 23 of the NESC.



FIGURE IV-6a
Attachment of Service Drop at Buildings - to the Pipe Mast

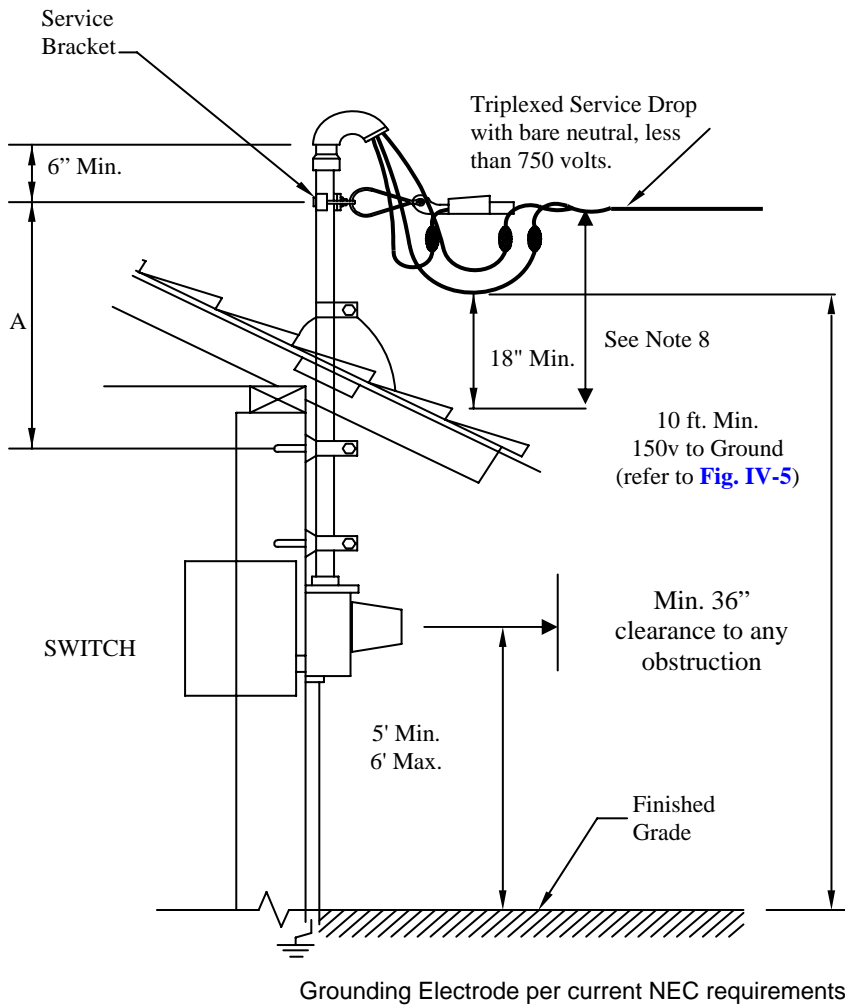

Maximum Service Bracket attachment height above last firm support (A)	
DIA. (in.)	Rigid Metallic * or IMC. (ft.)
2	2.5
2-1/2	4.75
3	7.66
3-1/2	10.66

*Rigid Metallic shall be per ANSI C-80.1 and shall be hot dipped galvanized inside and out.

Notes:

1. A service Mast may be used to get proper clearance if permitted by local code.
2. The Service Drop and Service Bracket are provided and installed by FPL.
3. Service Mast or other approved attachment post or bracket must be sufficient strength to support the Service Drop. 2' or larger rigid galvanized conduit is preferred. The point of attachment must be sufficient height to provide minimum clearances. FPL will not attach Service Drop to an aluminum, EMT, or PVC mast.
4. Customer provides and installs Service Mast in accordance with National Electrical Code and/or local codes.
5. Minimum clearance to Drip Loops is 10 feet from ground. Minimum Drip Loop to Roof clearance is 18 inches.
6. Service Drop, Service Bracket and Meter are owned and installed by FPL. Meter Socket is owned, installed and maintained by customer.
7. Service Drop clearance required at locations other than a house are shown in Fig. IV-5.
8. For triplexed or quadraplexed cable services, less than 750 volts, with bare neutral, the 18" minimum clearance is allowed only where no more than 6 feet, measured horizontally, of the service drop passes over a roof to terminate at a through-the-roof mast located not more than 4 feet, measured horizontally, from the nearest edge of the roof. Otherwise, the minimum clearance above the roof (not readily accessible) of the building to which the service is attached is 3 feet. Refer to NESC 234C3d.



FIGURE IV-6b

Attachment of Service Drop at Buildings - to the Structure

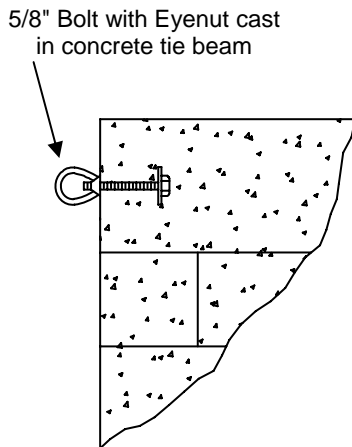

If point of service attachment can be determined before construction, an effort should be made to have eyebolt installed during construction

ALTERNATIVE #1

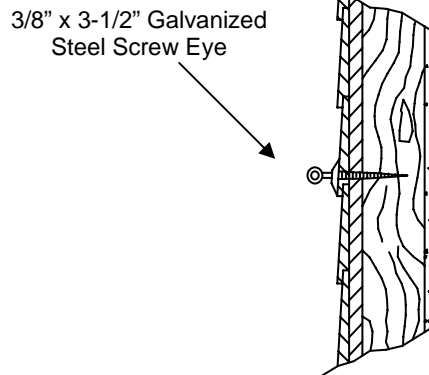

When attachment must be made to building frame use 3/8"x3-1/2" Screw Eye. Drill thru siding with 3/8" bit. Use 1/4" bit to precede screw into stud.

ALTERNATIVE #2

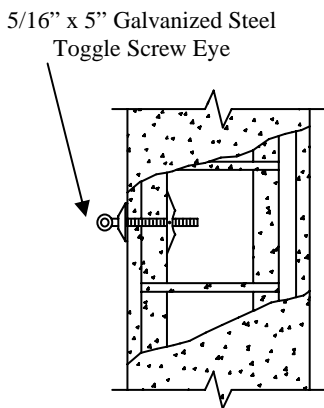

Use Toggle Screw Eye on hollow tile or concrete block walls

ALTERNATIVE #3

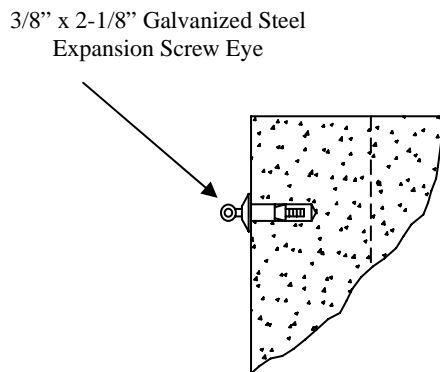

Use Expansion Screw Eye in poured concrete walls or beam

ALTERNATIVE #4

NOTE: Where local building codes are more conservative, they take precedence.



FIGURE IV-6c
Attachment of Service Drop at Buildings - to the Wood Eave
TYPICAL METHODS

To be used only when anchorage into wall will not provide proper ground clearance

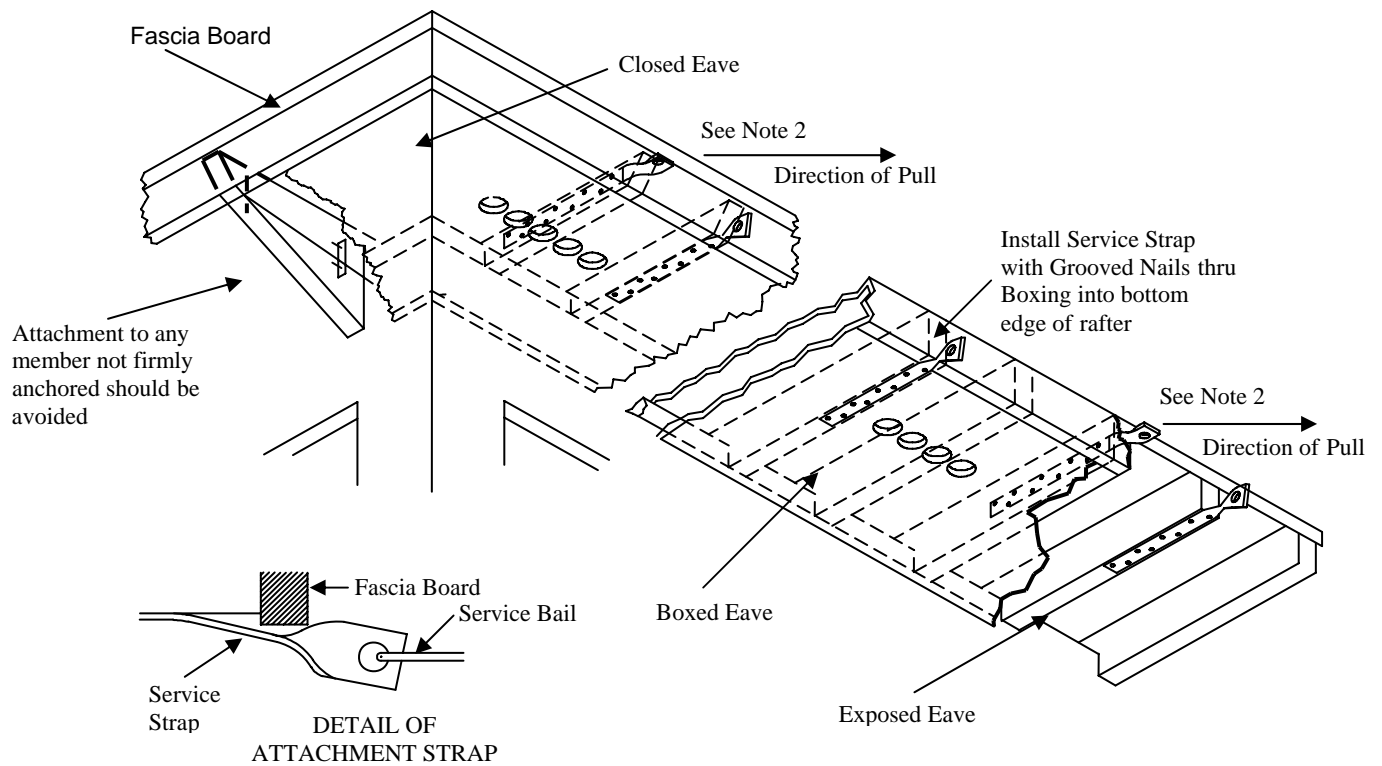

Notes:

1. Attach Service Strap with 2-1/2", No. 8 gauge "Anchor Fast" grooved nails.
2. If angle between Service Strap and Service Cable is greater than 45 degrees, the strap should be attached on side of rafter opposite direction of Service Pull.



Electric Service Standards

DATE
07-13-11

PREPARED BY

SUBJECT

SECTION: PAGE

Distribution Construction Processes

IV. SERVICE and METER CONNECTIONS

IV: 14 of 24

FIGURE IV-7 Outdoor Meter Installation - 1ph 120/240v 3 wire Overhead Service

FPL furnishes, installs, and maintains service drop and makes connection to customer's service entrance conductors

Customer must identify neutral at weatherhead

For service drop clearance, see Fig IV-5

Customer furnishes, installs and maintains service entrance conductors and conduit (per local code)

FPL furnishes anchor bolt to be installed by customer (no further than 24" from mast)

Mount meter socket securely and level in horizontal and vertical planes

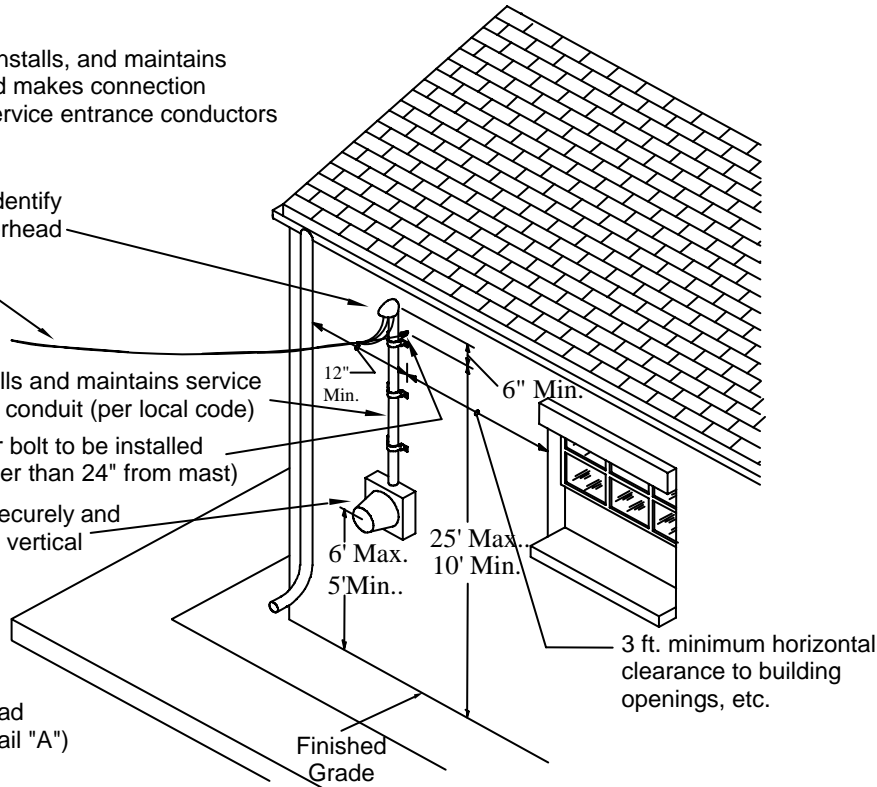

NOTE: Customer must provide adequate grounding of facilities in accordance with the NEC and local codes.

To Weatherhead (see Fig. IV-8, Detail "A")

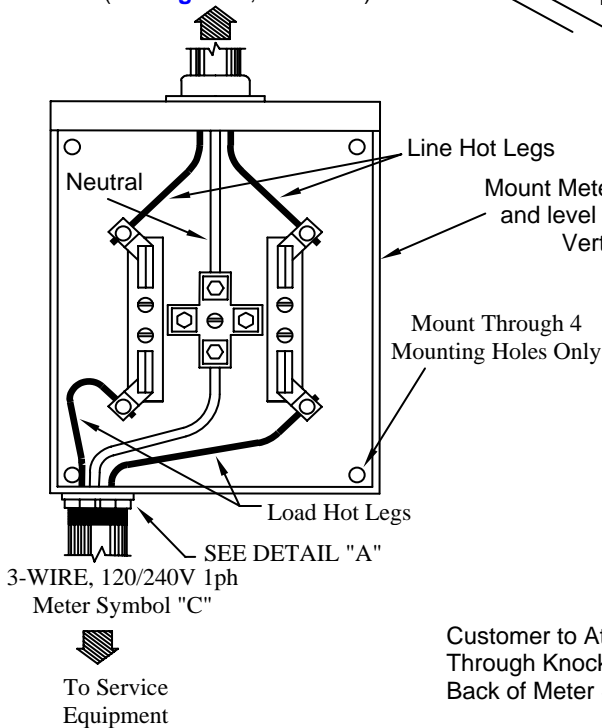

Customer to Furnish and Install Grounding Bushing & Bonding Conductor where required by National Electric Code

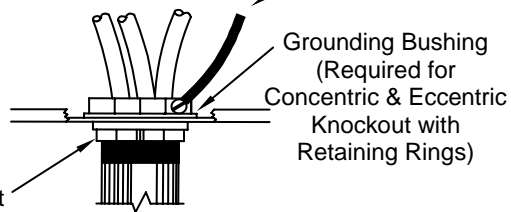

Customer to Attach Conduit Through Knockout Bottom or Back of Meter Socket

DETAIL "A" BONDING AROUND CONCENTRIC & ECCENTRIC KNOCKOUTS



FPL

Electric Service Standards

DATE

07-13-11

PREPARED BY

SUBJECT

SECTION: PAGE

Distribution Construction Processes

IV. SERVICE and METER CONNECTIONS

IV: 15 of 24

FIGURE IV-8 Self Contained Meter Installation - Overhead Service

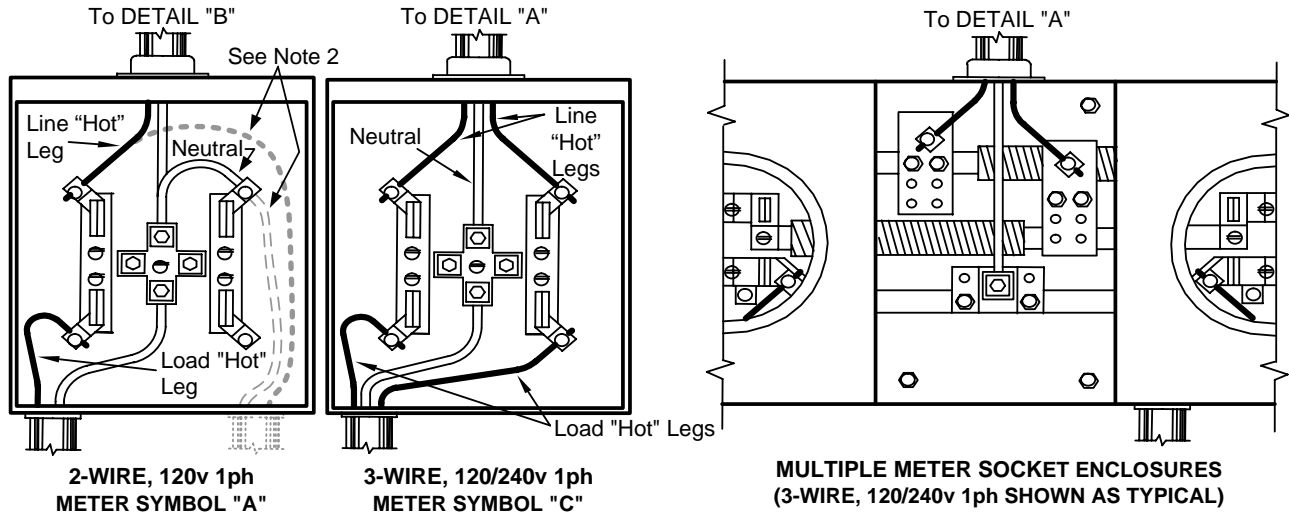

2-WIRE, 120v 1ph
METER SYMBOL "A"

3-WIRE, 120/240v 1ph
METER SYMBOL "C"

MULTIPLE METER SOCKET ENCLOSURES
(3-WIRE, 120/240v 1ph SHOWN AS TYPICAL)

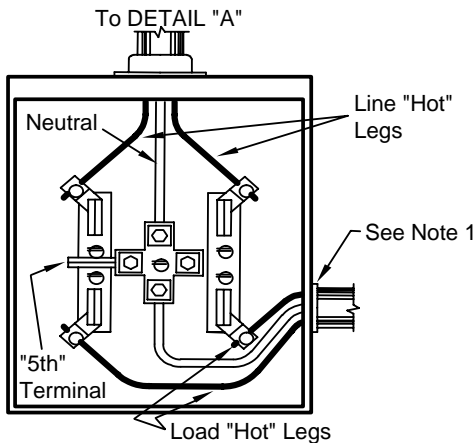

3-WIRE, 120/208Y 1ph
(2 STATOR NETWORK)
METER SYMBOL "E"
3-WIRE, 240/480v 1ph
METER SYMBOL "G"

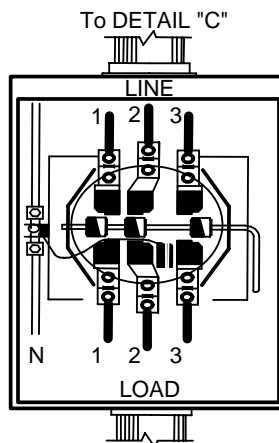

4-WIRE, 3ph
DELTA METER SYMBOL "J"
WYE METER SYMBOL "L" & "N"

Meter Cans with By-Pass Handles

Commercial Applications:

Wiring similar for wye and delta, but on delta, Hot Wire #3 (hi-leg) must be 208v to ground and must be connected to right terminal as shown (other two hot wires, lighting legs, are 120v to ground).

Underground Residential Applications:

Risers for FPL underground services must be installed on the opposite side of the meter can from the customer's service entrance conductors. Customer's conductors **MUST** be kept entirely to one side of the meter can, leaving the opposite side of the meter can unobstructed for FPL's conductor.

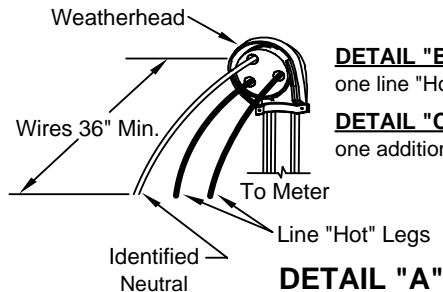

DETAIL "B" same as DETAIL "A", but only one line "Hot" Leg

DETAIL "C" same as DETAIL "A", but with one additional line "Hot" Leg

Note:

1. Customer to bond around concentric knockouts. See Fig. IV-7, Detail "A"
2. For 2-wire installations served from an underground riser, the line neutral conductor may be passed continuously through the upper right lug (shown dashed in figure).



FPL

Electric Service Standards

DATE

07-13-11

PREPARED BY

SUBJECT

SECTION: PAGE

Distribution Construction Processes

IV. SERVICE and METER CONNECTIONS

IV: 16 of 24

FIGURE IV-9 Lug-Type Meter Socket Installations

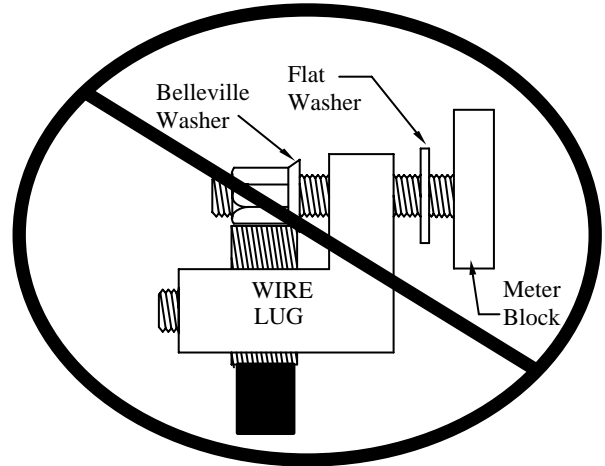
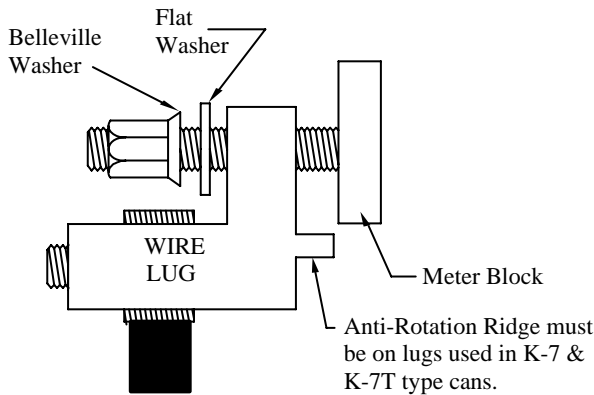

ACCEPTABLE

NOT ACCEPTABLE

PROPER INSTALLATION OF WASHERS & LUGS ON LUG-TYPE METER CANS

Be sure the flat washer is placed between the Belleville Washer and the wire lug. This installation will ensure the maximum surface contact area of the lug and the meter block.

Be sure the wire is placed properly in the lug so it will not interfere with the tightening of the Belleville Washer.

The lug used in the 400 amp (K-7) and 600 amp (K-7T) cans must have an anti-rotation ridge as shown. This ridge is not required in smaller cans.

ACCEPTABLE CONFIGURATIONS

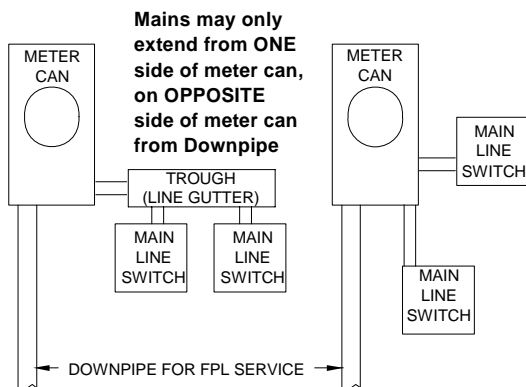

NOT ACCEPTABLE

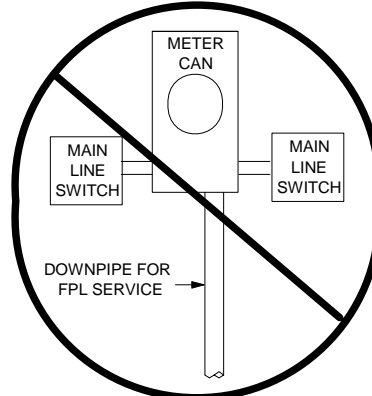

When customers conductors are parallel, customers conductors **MUST** be kept entirely to one side of the meter can, leaving the opposite side of the meter can unobstructed for FPL's conductor. When load conductors enter through the bottom rear of the meter can they must be kept entirely to one side so not to interfere with the FPL conductor.

FIGURE IV-10

Intersystem Bonding Termination

NEC Section 250.94 has been revised in the 2008 Code, thereby affecting all new installations and existing installations where alterations are made. As part of this revision, the Code has identified a new device called the **Intersystem Bonding Termination** or IBT. The 2008 NEC defines the IBT as "a device that provides a means for connecting communications system(s), grounding conductor(s) and bonding conductor(s) at the service equipment or *metering equipment enclosure** or at the disconnecting means for buildings or structures supplied by a feeder or branch circuit."

PREFERRED INSTALLATION

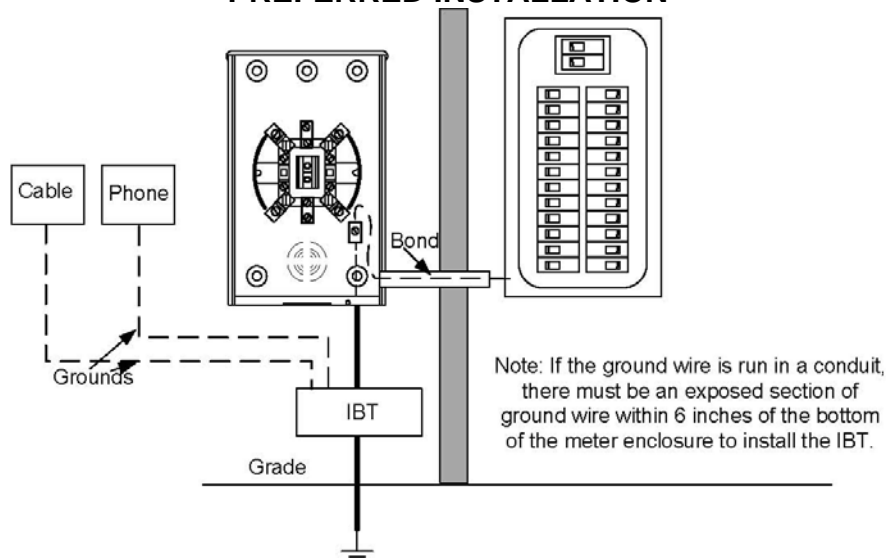

ALTERNATE INSTALLATION

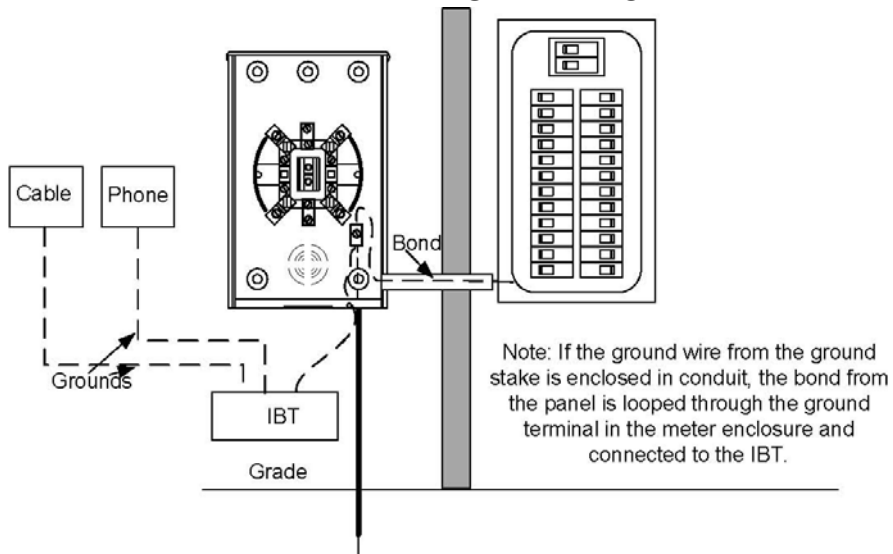
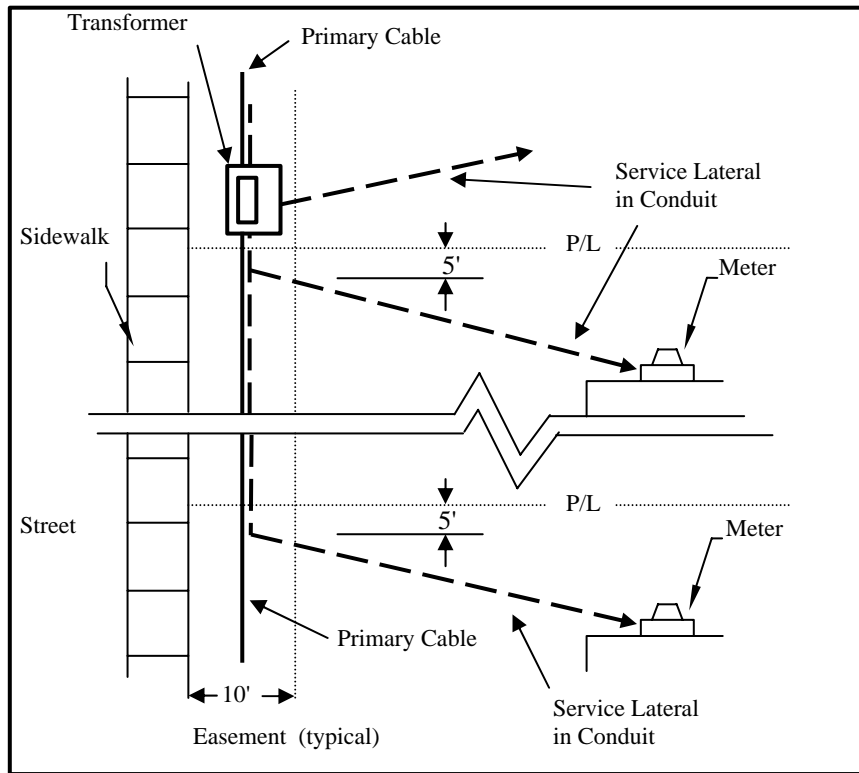



FIGURE IV-11a
URD System Layout - Typical



NOTES: (APPLICABLE TO FIGURES 11a and 11b)

1. Backfill adjacent to cable must be free of boards, debris, and rocks larger than 1" in diameter.
2. Aim service conduit towards designated source of Company's service. End of conduit must be at least 24" away from any permanent structure (patio, porch, etc.) measured at right angle from the structure. Cap or plug the end of pipe.
3. The service lateral must cross the property line within the limits of the easements and should be in a direct line to meter as nearly as practical. It must have at least 5' horizontal clearance to any swimming pool.
4. Conduit bend requirement of National Electrical Code Section 346-10 "the internal diameter of the conduit will not be effectively reduced."
5. With FPL approval, slight variances in customer's downpipe size may be accepted if suitable adapter fitting is also provided by the customer. For example, 2-1/2" downpipe may be accepted if adapter to FPL 2" PVC conduit is provided.
6. Conductor sizes shown in tables are for triplex cables.
7. If load conductors enter from the side, entrance must be opposite side of FPL conductors. When two load conduits are used, they must be kept to one side of the can, allowing space for the line conductors. See [Figure IV-9](#). Center position may not be used for the downpipe.
8. Schedule 80 PVC is acceptable to use, where an obstruction exists at the downpipe the customer must extend the service conduit a minimum of 24" past the obstruction. FPL will provide the 90 degree bend, if the customer provides the 90 degree bend it must be a 24" radius bend. **Field Bends are NOT acceptable!**



Electric Service Standards

DATE
07-13-11

PREPARED BY
Distribution Construction Processes

SUBJECT
IV. SERVICE and METER CONNECTIONS

SECTION: PAGE
IV: 19 of 24

FIGURE IV-11b
FPL Buried Service Lateral – Meter Socket & Down Pipe Requirements
(references to notes shown in [Figure IV-11a](#))

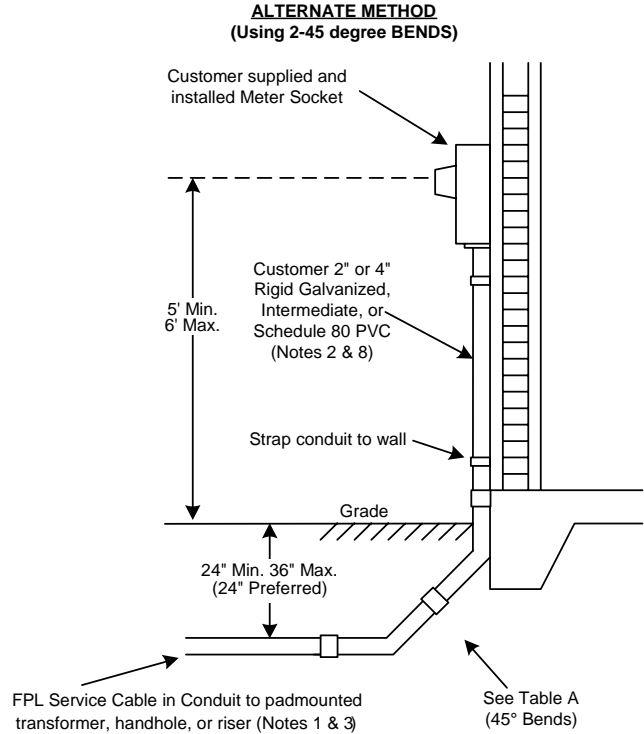
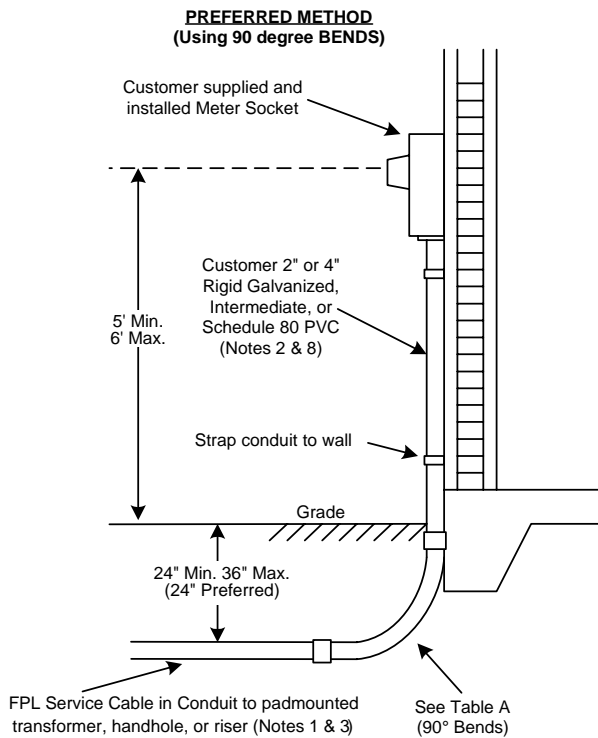

EXTENDING CONDUIT 24" BEYOND OBSTRUCTIONS

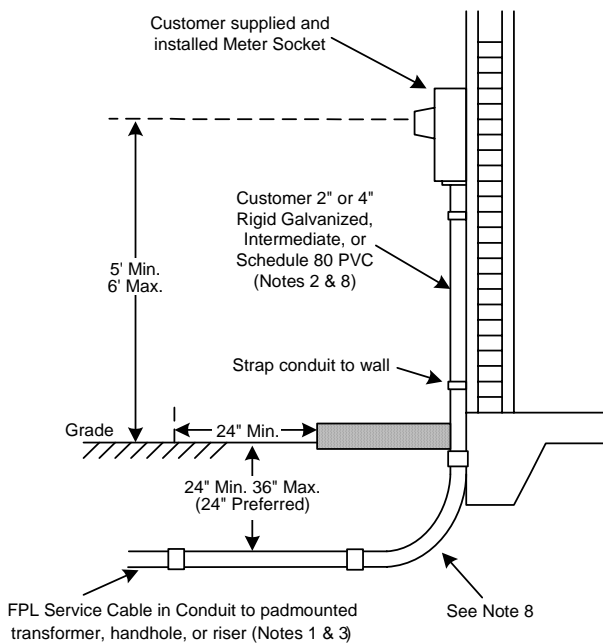

METER SOCKET FOR RESIDENTIAL

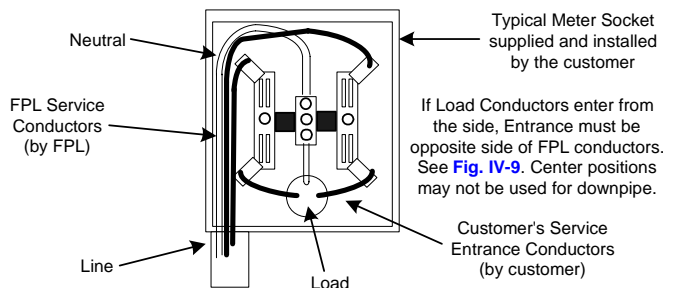

IMPORTANT - Please distinguish between Overhead and Underground (URD) Meter Sockets when purchasing. (See FPL Approved List in [Section VII](#))

Note: If FPL Service Conductors (line side) are parallel #4/0 triplex, then the customer shall provide and install connectors designed for multiple conductors in the meter socket.

Table A

Wire Size Cu or Al	Down Pipe	90° Bends		45° Bends	
		Bends	Radius	Bends	Radius
1/0 or 4/0	2"	(1) 2" - 90°	24"	(2) 2" - 45°	18"
2 - 4/0	2 - 2"	(2) 2" - 90°	24"	(4) 2" - 45°	24"
2 - 4/0	4"	(1) 4" - 90°	36"	(2) 4" - 45°	24"



FPL

Electric Service Standards

DATE

07-13-11

PREPARED BY

SUBJECT

SECTION: PAGE

Distribution Construction Processes

IV. SERVICE and METER CONNECTIONS

IV: 20 of 24

FIGURE IV-12b Residential Multiple Occupancy Buildings - Multiple Meter Center

Multiple Meter Center must appear on the Approved List
*Residential Application Shown

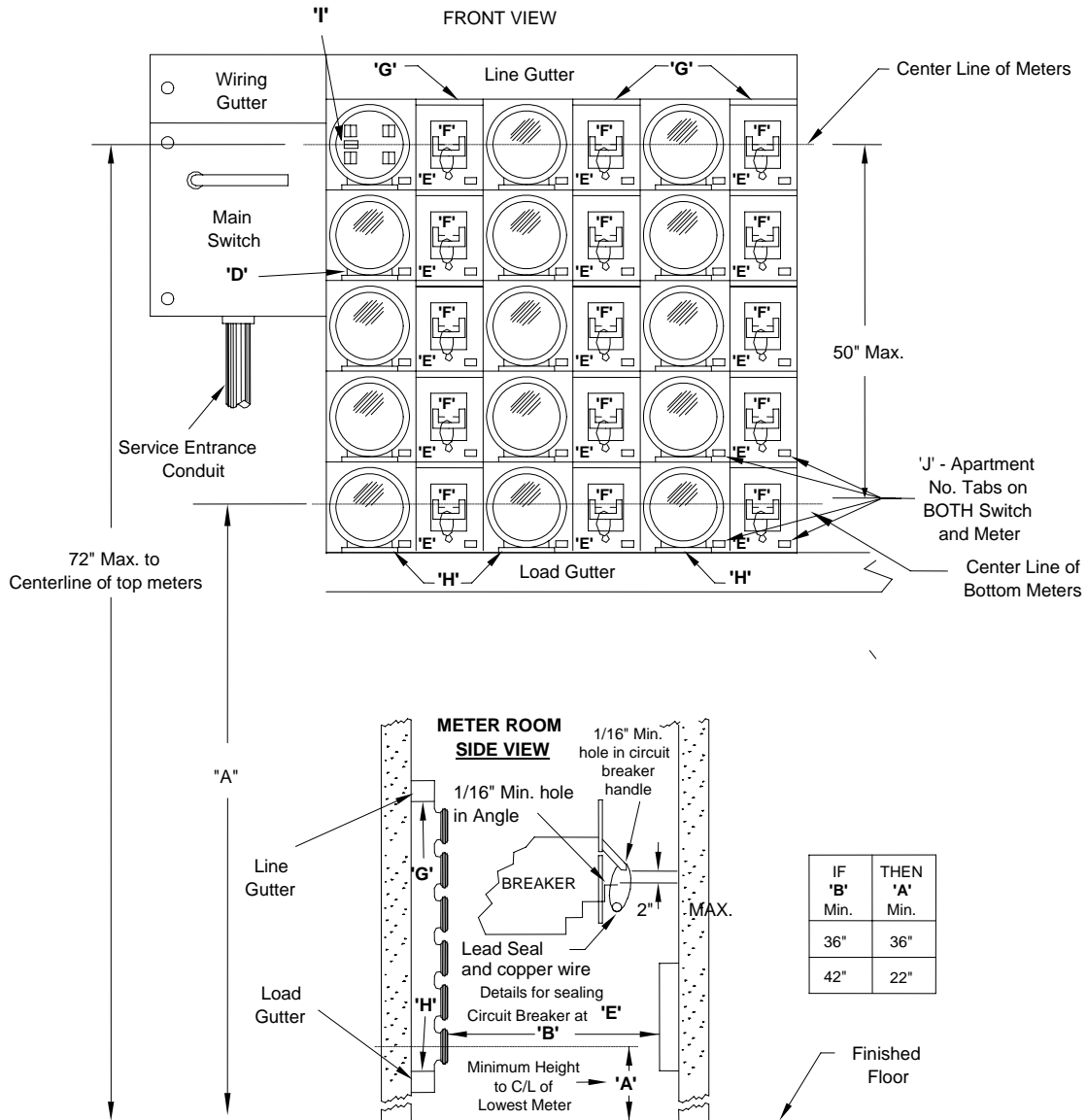

- 'B' - Horizontal clearance of meter face to opposite wall or equipment thereon.
- 'D' - Approved captive screw-type sealing ring when socket is ring type.
- 'E' - Provision for sealing each breaker 'F' in off position.
- 'F' - Common trip load breaker for each unit. Breakers are preferred on load side of meter socket.
- 'G' - Fiber or metal barrier at these points to separate line wires from metered circuits.
- 'H' - Fiber or metal barrier at these points to separate metered circuits from line busses.
- 'J' - Permanent identification tag must be placed on both meter and breaker face plates.
- 'I' - Fifth terminal to be provided when used on 120/208 volt three wire, and is acceptable only in the 9 O'clock position as shown.

* Non-residential and 3 phase applications require lever by-pass, jaw tension/release socket blocks



FIGURE IV-13a
Remote Meter Location, Typically used for Service to a Mobile Home

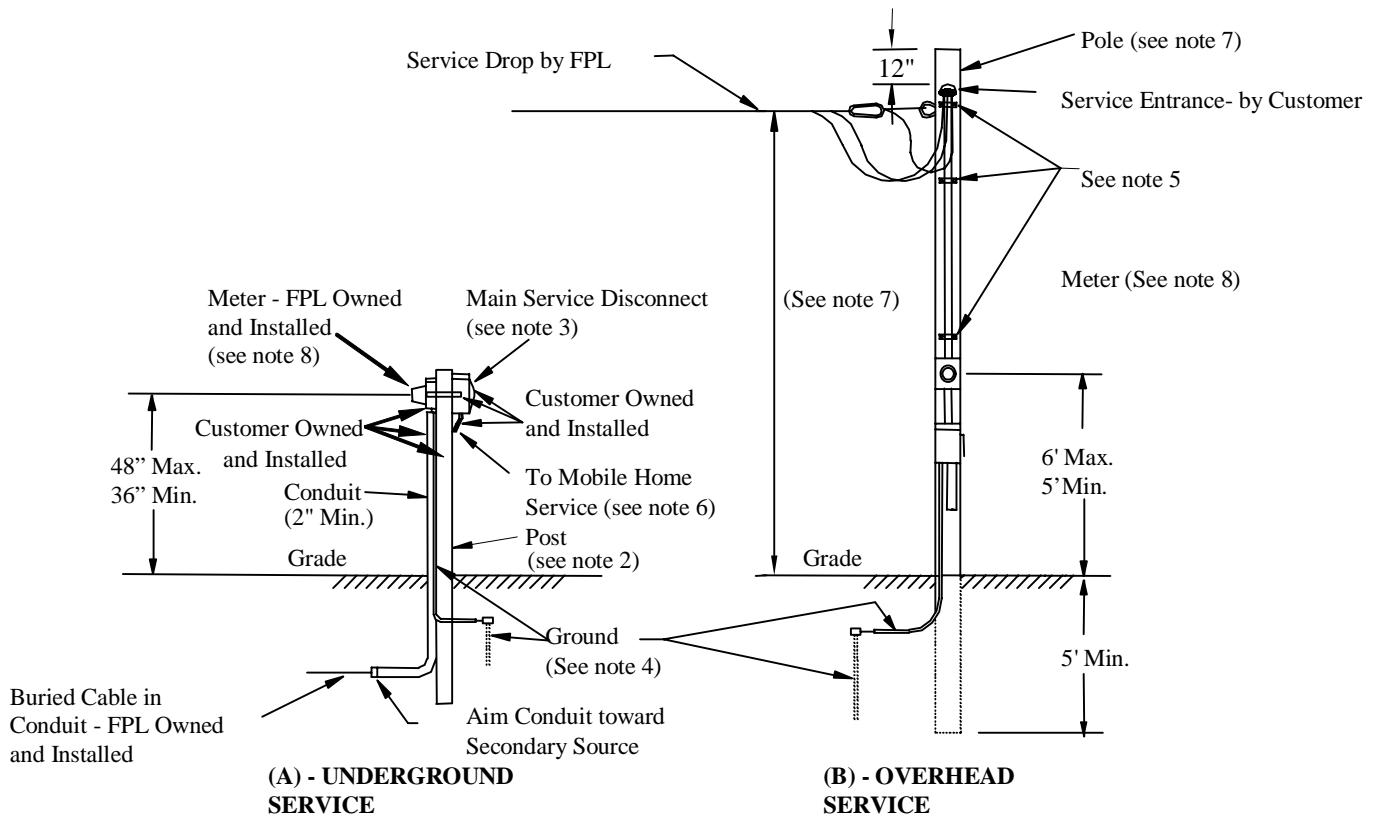

NOTES:

1. Space under meter socket on post to be reserved for conduit.
2. Post to be constructed of reinforced concrete (5"x5"), 4"x4" pressure treated wood, 2" galvanized steel pipe with 2" concrete encasement below ground level, or equivalent.
3. Circuit breaker or main service fused disconnect (outdoor type) National Electrical Code.
4. The customer must ground facilities as required by the National Electrical Code and applicable local codes (refer to section VIII of this FPL Electric Service Standards issue).
5. Customer will install a sufficient number of conduit straps to properly secure conduit to pole.
6. Customer service may be run underground in conduit from bottom of main switch.
7. Customer's class 6 or 7 pressure treated wood pole, or equivalent, set a minimum of 5' deep. Must provide minimum service drop clearances shown in [Figure IV-5](#).
8. Meter - Furnished and installed by FPL. Meter socket furnished and installed by customer.

**FIGURE IV-13b
Pedestal Service - Customer Provided Meter Pedestal (typical)**

Meter pedestal must be rigid enough to withstand force applied when meters are installed.

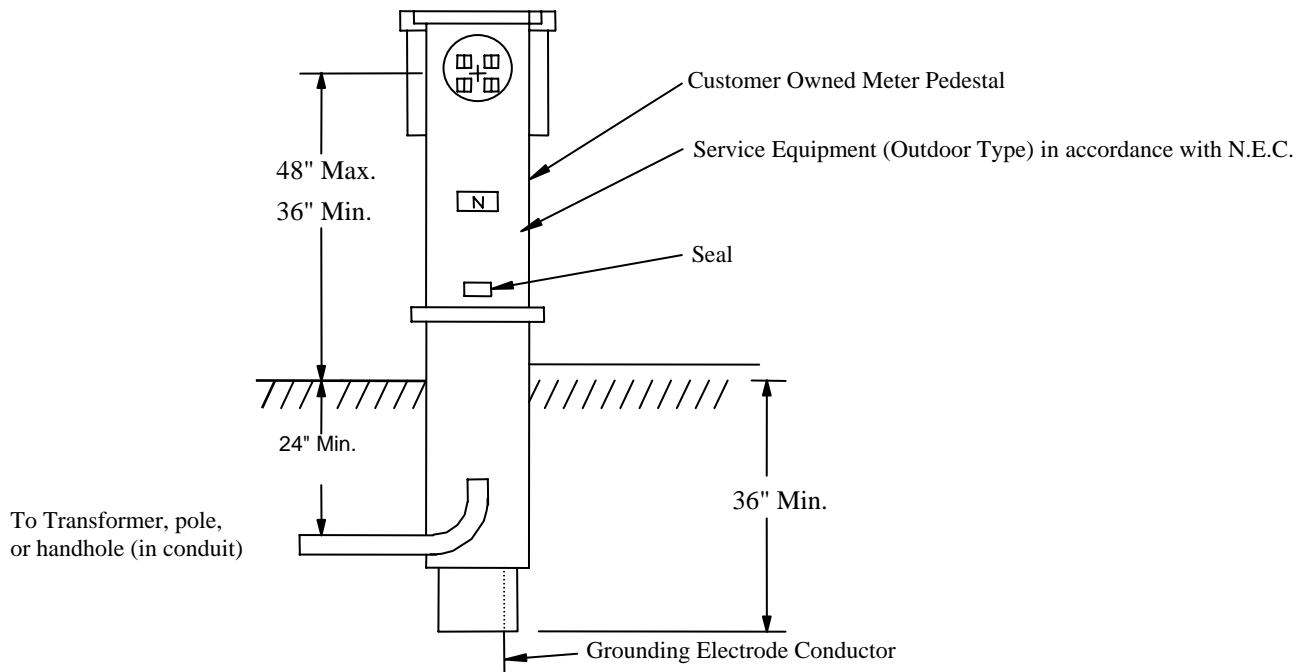

The customer must ground facilities as required by the National Electrical Code and applicable local codes. See [Section VIII](#) of this FPL Electric Service Standards.

Notes:

1. Meter pedestal must be on FPL's approved list, and equipped with standard meter socket.
2. Where FPL is providing the service lateral to the pedestal, refer to [Figure IV-11b](#) for downpipe specifications.
3. FPL Conductors may terminate in customer owned pedestal, but are not to be looped in and out of pedestal.
4. Meter pedestals may be used for residential services or for commercial installations serving non-critical loads. Refer to [IV-A.1](#) for examples.



FIGURE IV-13c
Mobile Home Service - "Grouped" Service to Mobile Homes

Main Service Fused Disconnect or Circuit Breaker (Outdoor Type) sized according to the National Electrical Code.

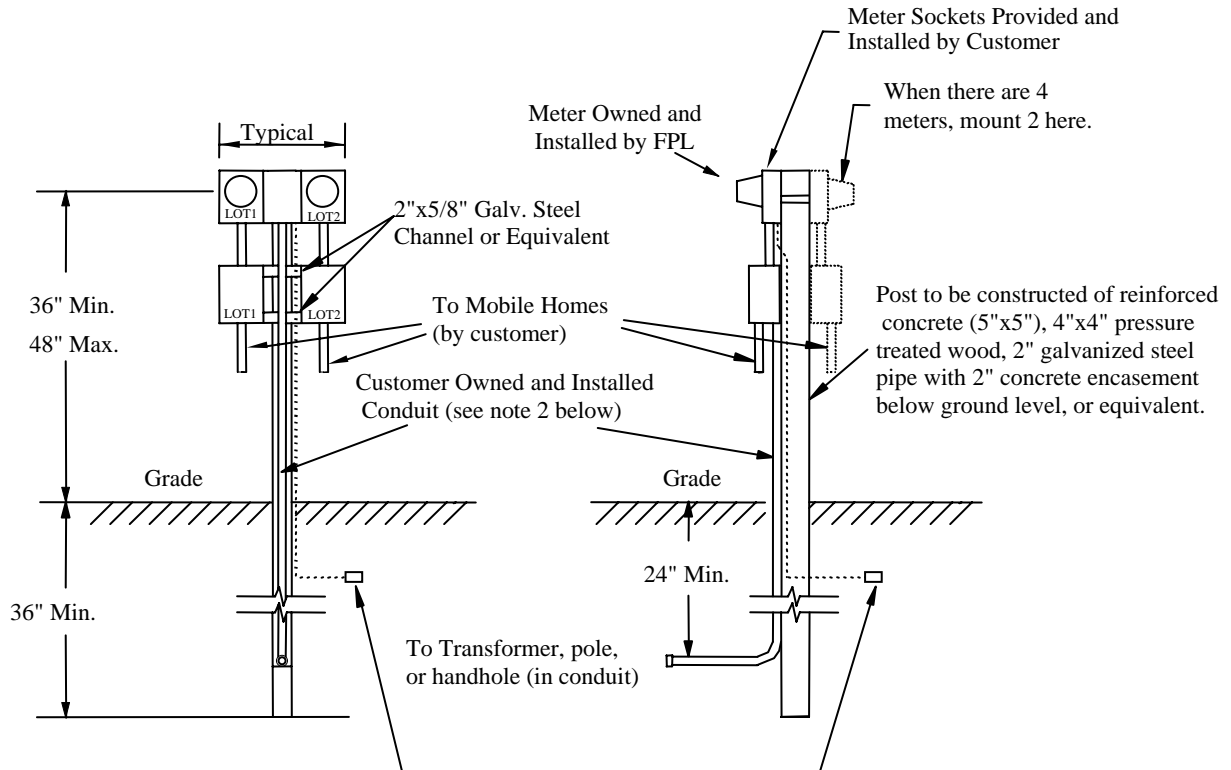

The customer must ground facilities as required by the National Electrical Code and applicable local codes. See [Section VIII](#) of this FPL Electric Service Standards.

NOTES:

1. Customer must permanently mark meter socket and switch to indicate which unit they serve.
2. Where FPL is providing the service lateral to the pedestal, refer to [Figure IV-11b](#) for downpipe specifications.
3. Where FPL is providing the service lateral to the pedestal, a maximum of 4 units is allowed per pedestal.
4. Where FPL is providing the service lateral to the pedestal, FPL conductors will terminate in customer owned pedestal (they'll not be looped in and out of pedestal).



Electric Service Standards

DATE
07-13-11

PREPARED BY

SUBJECT

SECTION: PAGE

Distribution Construction Processes

IV. SERVICE and METER CONNECTIONS

IV: 24 of 24

FIGURE IV-14

Identification of Customer Cables

DIRECT BURIED AND CABLE IN CONDUIT SYSTEMS

Use plastic tags as shown in Figure 1 for customer identification at locations that will be subjected to sunlight, such as risers, and also in URD applications for identifying services, such as padmounted transformers and handholes. Plastic tags should have a clear, UV resistant flap to reduce fading and weathering. Use indelible (permanent) marker, and allow 10 seconds drying time to prevent smearing before adhering flap. Fasten tag to cable using plastic tie wraps. Blank tags are available upon request.

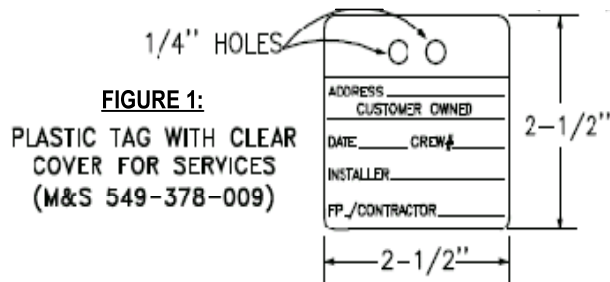

EXAMPLE OF MARKING SECONDARY CABLES

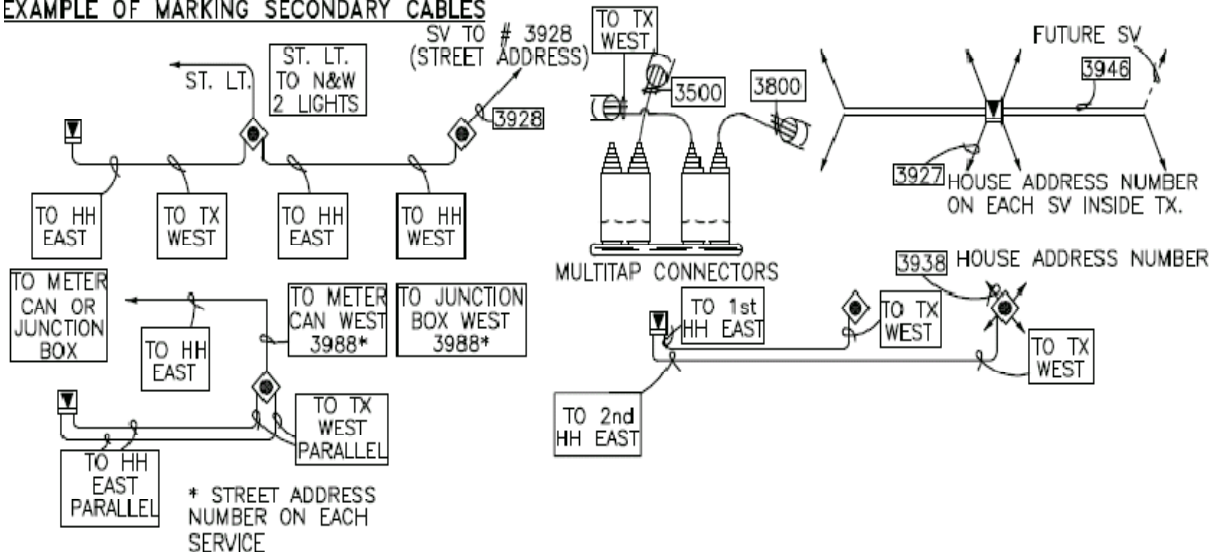



Electric Service Standards

DATE
01-28-11

PREPARED BY

Distribution Construction Processes

SUBJECT

V. REQUIREMENTS FOR TRANSFORMERS SITUATED ON CUSTOMER PROPERTY

SECTION: PAGE

V: 1 of 6

V. REQUIREMENTS FOR TRANSFORMERS SITUATED ON CUSTOMER PROPERTY

A. Padmounted Transformer Requirements

Complete requirements are contained in FPL specifications given to Customers for individual projects. Typical pad mounted transformer requirements include, but are not limited to the following:

The Customer Will:

- provide a transformer pad location per FPL specifications. For residential dwelling units, the transformer shall not be located closer than 15 feet from a door or window to the habitable portion of the dwelling unit (to minimize noise problems);
- pour and cure the concrete pad according to FPL specifications, or install the FPL supplied pre-cast pad, for transformers sized 750 KVA and larger;
- bring the service entrance conductors out to the transformer, installed in accordance with National Electrical Code requirements, leaving adequate cable, as determined by FPL, for FPL to make connections in the transformer, the number of cables limited as shown below:

Transformer KVA	Secondary Voltage	Max. Number of Conductors & Size		Max. Number of Conduits & Sizes
25 – 167 (Low Style)	120/240V	8 sets	4/0	8 – 2" Max
25 – 167 (High Style)	120/240V	8 sets	750 KCMIL	8 – 2" Max 4 – 4" Max
150 – 500	120/208V 277/480V	8 sets	750 KCMIL	8 – 4" Max
750	277/480V	8 sets	750 KCMIL	8 – 5" Max
750	120/208 V	12 sets*	750 KCMIL	12 – 5" Max
1000	277/480V	12 sets*	750 KCMIL	12 – 5" Max
1000	120/208V	12 sets*	750 KCMIL	12 – 5" Max
1500 - 2000	277/480V	12 sets*	600 – 750 KCMIL	12 – 5" Max
1500 - 2000	277/480V	14 sets*	500 KCMIL or less	14 – 5" Max
2500	277/480V	12 sets*	600 – 750 KCMIL	12 – 5" Max
2500	277/480V	16 sets*	500 KCMIL or less	16 – 5" Max

*An FPL provided secondary connection cabinet is recommended for new installations with more than 8 sets of 750 KCMIL or more than 12 sets of a smaller size conductor.

- maintain access to FPL to padmounted equipment located on the Customer's property (eight feet of clearance from the door side and three feet of clearance from other sides from items such as fences, shrubs and other obstructions are to be maintained by the Customer, as shown in **Fig. V-1**. FPL will help plan the Customer's installations of fences, shrubs, etc. near FPL facilities such that they will not obstruct access or cause damage to FPL's facilities. Where



Electric Service Standards

DATE

01-28-11

PREPARED BY

Distribution Construction
Processes

SUBJECT

V. REQUIREMENTS FOR TRANSFORMERS SITUATED ON CUSTOMER PROPERTY

SECTION: PAGE

V: 2 of 6

adequate access to FPL facilities is maintained, faster service restoration is made possible in the event of a power interruption.);

- provide suitable barriers, if specified by FPL, to protect the padmounted transformer and associated metering equipment from vehicular traffic;
- provide FPL with a suitable easement for the pad and distribution cables, including the right to install additional cables to serve other Customers, as required;
- clear trench route, have to grade, as specified in [section II.E](#);
- conform to the requirements of the National Electrical Code and applicable local codes (approval from the local inspecting authority shall be provided to FPL before FPL will connect service).

FPL Will:

- provide transformer specifications to the Customer;
- determine if a secondary connection cabinet will be required;
- provide and install the transformer, the concrete pad (if applicable), and the primary cable and conduit.

If only one, single-meter Customer is served (greater than 600 amps), and no future additional meters will be connected, current transformers may be placed in padmounted transformer before the Customer's service is tapped to its secondary. This would avoid the need for a current transformer cabinet. However, the meter socket and connecting conduit shall still be installed by the Customer. The meter socket will not be mounted on the padmounted transformer. The location of the meter socket will be specified by FPL.



Electric Service Standards

DATE

01-28-11

PREPARED BY

SUBJECT

SECTION: PAGE

Distribution Construction Processes

V. REQUIREMENTS FOR TRANSFORMERS SITUATED ON CUSTOMER PROPERTY

V: 3 of 6

FIGURE V-1

PROTECTIVE BARRIER AND PLANTING CLEARANCES FOR PADMOUNTED TRANSFORMERS AND SWITCHES

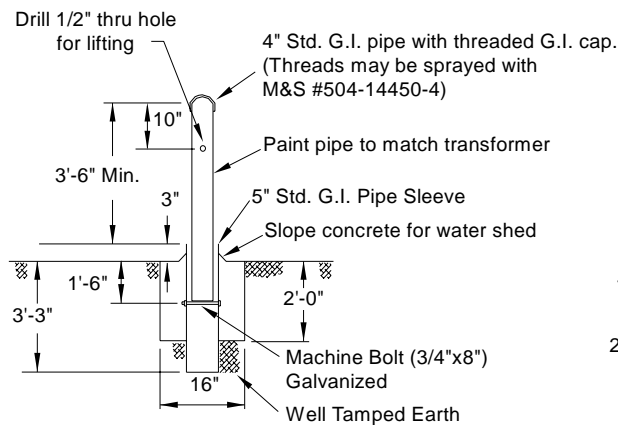
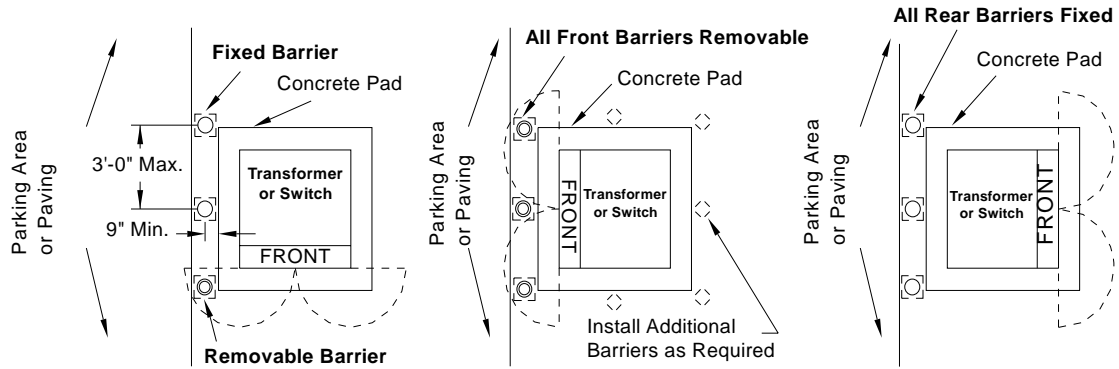

REMOVABLE BARRIER

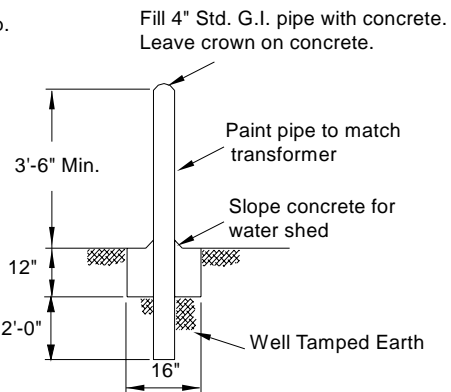

FIXED BARRIER

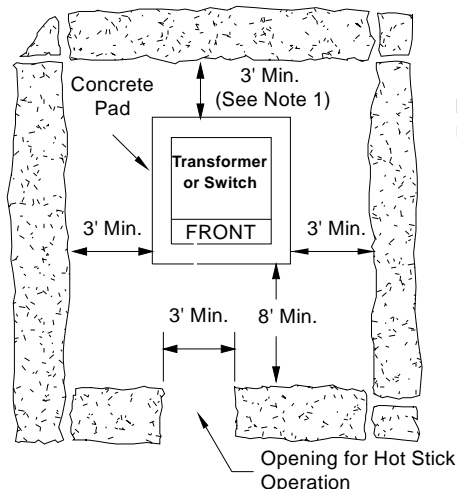

Note 1 - Padmounted switches require 8' minimum clearance in the front and the rear.



Electric Service Standards

DATE

01-28-11

PREPARED BY

Distribution Construction
Processes

SUBJECT

V. REQUIREMENTS FOR TRANSFORMERS SITUATED ON CUSTOMER PROPERTY

SECTION: PAGE

V: 4 of 6

B. Vault Requirements

Complete requirements are contained in FPL specifications given to Customers for individual projects. Typical vault requirements include, but are not limited to the following:

The Customer will:

Provide construct and maintain the transformer vault in accordance with applicable codes and FPL specifications, which specify, but are not limited to:

- necessary layout information for such vaults, including the size, location and number of conduits to be stubbed out;
- Customer to stub out ducts as specified beyond the building foundation, as shown on specifications vault drawing (fiber, plastic, or transite ducts shall be enclosed in concrete. Ells shall have a minimum radius of 36 inches);
- in grade level vaults, Customer will provide 1 1/4 inch plastic conduit sleeves at specified locations through the concrete floor for FPL's ground rods;
- provisions for adequate vault ventilation, as shown (ventilating fans, if needed, will be installed by FPL);
- doors shall open outward, and shall have a hasp for padlocking or mortised openings for FPL provided Customer installed cylinder dead lock set. Locks and latches shall be so arranged that the door may be readily and quickly opened from the inside. Doors opening into the building shall be tight fitting and of a type approved for a class A situation (see NFPA No. 80, latest edition). Customer is responsible for maintenance of walls, roof, doors and windows;
- FPL provided, Customer installed pulling eyes opposite each duct entrance. Pulling eyes shall be tied into building steel and capable of withstanding 10,000 pounds tension in direction shown in specifications;
- floors of vault to have adequate structural strength to support the vault equipment;
- drainage facilities provided and installed as required by applicable codes for "Transformer Vaults" (door sill of height as specified, minimum of four inches);
- means of direct access to vault from outside for personnel and equipment, through doors opening outward (if this cannot be done, special arrangements shall be agreed on for moving personnel and equipment into and out of the vault. These arrangements shall be included in an addendum to the standard specifications);
- if metering current transformers are located in the vault, Customer shall provide a continuous 1 1/4 inch metallic (threaded bushing on ends) or schedule 80 PVC conduit (without condulets) from the meter socket or cabinet to the inside of the vault wall (no metering equipment except instrument transformers are to be in the vault. Maximum distance of metering devices from conduit termination in vault to be ten feet, or FPL approved distance) **with a maximum of 2 – 90 degree bends;**
- special restrictions (no pipes for sanitary plumbing, water or gas supply or for any other purpose foreign to the vault installation shall pass through the transformer vault; no toilets or wash basins shall be installed in the vault; any conduit or piping required in connection with sump pumps or other necessary equipment shall be insulated electrically from the exterior of the vault; vaults shall not be used for storage, nor for any other purpose than to contain



Electric Service Standards

DATE

01-28-11

PREPARED BY

Distribution Construction
Processes

SUBJECT

V. REQUIREMENTS FOR TRANSFORMERS SITUATED ON CUSTOMER PROPERTY

SECTION: PAGE

V: 5 of 6

and protect the transformers and necessary equipment);

(Note: Customer should submit the vault specifications to the appropriate authorities for their information at time of submitting construction plans for approval.)

- provide and install his service entrance and bring his secondary service conductors into the transformer vault through designated areas only, leaving sufficient cable length in the vault for FPL to connect to its facilities. He will install meter protective equipment, in accordance with vault specifications;
- grant to FPL an easement for the FPL conduit and cables within the Customer's property.

FPL Will:

- provide vault specifications to the Customer;
- where accessible to employment of rapid and customary methods of construction, provide and install conduit from the conduit stubs at the transformer to its facilities;
- provide, install, and connect the primary cable to the transformer vault;
- provide and install the necessary transformer(s) and switching equipment;
- perform all work inside the transformer vault associated with rendering electric service (with the exception of pulling customer cables);
- maintain all of its facilities from its pole or manhole to where the Customer's secondary service conductors are connected to FPL's facilities;
- keep the vault locked (FPL will give the Customer escorted access to the vault, when necessary, upon request);
- reserve the right to install the necessary cables, conduit, and other facilities that may be required for supplying service to other Customers from the vault;
- allow only the supply transformers and associated FPL equipment in the vault (No meters or Customer secondary fuses, switches, communications or other Customer equipment are to be installed therein. Secondary devices and meters, however, are to be installed as near the transformer vault as practicable, but not in it).



Electric Service Standards

DATE

01-28-11

PREPARED BY

Distribution Construction
Processes

SUBJECT

V. REQUIREMENTS FOR TRANSFORMERS SITUATED ON CUSTOMER PROPERTY

SECTION: PAGE

V: 6 of 6

C. "Stacked Vault" Requirements

Complete requirements are contained in FPL specifications given to Customers for individual projects. Typical stacked vault requirements include, but are not limited to the following:

The Customer will:

- provide, construct and maintain the vaults in accordance with FPL's specifications, the National Electrical Code and any local building code;
- provide ducts enclosed in at least two inches of concrete, for FPL's primary cables;
- provide soundproofing necessary to contain the noise from transformers, each having a noise level of 45 Decibels. The Customer agrees to take responsibility for any noise problem;
- install non-louvered metal clad doors, with cylinder dead locks, as called for in the specifications. The locks will be provided by FPL, installed by the Customer;
- provide vault ventilation, as called for in the specifications;
- provide adequate structural strength to support 4,500 lbs. for each transformer to be installed in each vault. He will provide, where required by FPL, a 7/8" galvanized pull iron in the ceiling, as near as practical over each duct bank entrance through the floor, for pulling and supporting cables. The pulling iron shall be tied into the building steel and shall be capable of withstanding 10,000 pounds of tension;
- provide a minimum of 4 ft. wide and 7 ft. high unrestricted and unlocked passageway, with a floor capable of supporting 3,500 lbs. concentrated load, from outside the building to each "stacked" vault. Passage through the doorway may be reduced to 42 inches wide by 80 inches high;
- provide an elevator with minimum rated capacity of 3,500 lbs. and minimum clear door opening of 42" wide by 80" high, as called for in the specifications;
- provide and install single phase, 120/240 volt secondary service entrance conductors into the vaults through designated areas only, leaving sufficient cable to reach the point of connection to FPL's facilities;
- not use the vaults for storage, or for any other purpose than to protect the transformers and necessary equipment incident thereto.

FPL Will:

- provide and install all equipment and material in the vault, including lighting fixtures and wiring for this equipment;
- provide and install fans, if applicable as described under "Ventilation" in the specifications;
- provide and install all primary cable in ducts provided by the Customer, in duct runs between "main vault" and "stacked" vaults and between "stacked" vaults;
- maintain all equipment and material installed by FPL.



Electric Service Standards

DATE
10-24-11

PREPARED BY

SUBJECT

SECTION: PAGE

Distribution Construction Processes

VI. METERING EQUIPMENT

VI - 1 of 17

VI. METERING EQUIPMENT

A. Equipment Furnished and Installed by FPL

FPL provides and installs, at its expense, adequate metering instruments to measure the electric service used by the Customer. Usually, only one watthour meter per Customer is needed. However, FPL will furnish whatever metering, in its opinion, is required.

Instrument transformers are provided and installed by FPL when the voltage or current exceeds the rating of FPL's standard self-contained meter. Generally, current transformers will be used if the service is greater than 600 amperes (320 amperes for 480V, 2 wire service). Close coordination between the Customer and FPL is required to ensure these instrument transformers are installed at the most appropriate time.

B. Equipment Furnished, Installed, and Owned by the Customer

All meter sockets (meter enclosures) are to be provided and installed by the Customer and shall be listed on FPL's approved meter enclosure list.

For commercial, self-contained metering, FPL requires meter sockets with lever by-pass capability to eliminate service interruptions on meter changes.

All Instrument Transformer (IT) rated metering equipment enclosures are to be provided and installed by the Customer. These include IT rated meter sockets, wall mounted and weatherhead IT cabinets, and miscellaneous junction boxes/utility cabinets (**Fig. VI-2 thru VI-7**). Refer to FPL Specification 6.3.4 Customer Owned Instrument Transformer Cabinets, Equipment Enclosure & Junction Boxes. For padmounted primary metering, the customer has two options. FPL will provide the metering cabinet and charge the customer the cost of the cabinet, or the customer will provide a padmounted metering cabinet found in FPL's approved meter enclosure list. For primary metering in vaults, FPL will provide, install, and maintain the primary metering cabinet.

In some cases, the Customer might prefer prefabricated, combination socket and disconnect assemblies for multiple occupancy buildings (e.g. apartment or condominium buildings, shopping centers, etc.) as shown in **Fig. IV-12b**, or pedestal mounted equipment for mobile home parks as shown in **Fig. IV-13b**. Such equipment for all three phase and nonresidential installations shall contain lever by-pass, jaw tension/release socket blocks. It shall be the Customer's responsibility to obtain authorization from FPL to use this equipment for a particular installation before committing to its use. FPL maintains an approved list of equipment. Information and specifications on any such special meter equipment not on FPL's approved list shall be submitted to FPL for approval before installation. Refer to FPL Specification 6.3.1 Customer Owned Meter Enclosures for Self-Contained Watthour Meters and the Approved Metering Equipment Enclosure List found in **Section VII** in this publication.

On all self-contained, metered installations where the service voltage is 480V to ground (320 amperes or less, 2 wire), a non-automatic disconnect device shall be provided and installed by the Customer on the line side of each individual meter. For meter centers, there shall be one disconnect device on the line side of each meter. The disconnect device shall be lockable or sealable by FPL and adjacent to each meter. The Customer-owned non-automatic (no over current protection) disconnect device ampacity must meet all NEC Guidelines. A bypass equipped meter enclosure is required and shall be selected from the Approved Meter Equipment Enclosure List.



Meter socket enclosures and CT cabinets shall not be used as raceways for other conductors. Splices (straight or wye) are not allowed inside meter enclosures, conductor must be continuous. Lugs designed for multiple conductors are only allowed on the line side of the meter if the conductors must be paralleled from the FPL source (i.e. - the ampacity of a single conductor is insufficient to serve the load) and the lugs are listed for such use. These lugs shall not be used to provide a source for a second meter enclosure (i.e. - two meter enclosures served from a single service). Lugs designed for multiple conductors are allowed on the load side of the meter as long as the total load of the conductors does not exceed the rating of the meter or the service, and the lugs are listed for such use.

C. Metering Configurations & Approved Equipment

FPL specifies the metering configuration (See **Fig. VI-1**) for each service to be metered. FPL also requires that previously approved enclosures be used for each installation. The Customer is responsible for using the correct and approved enclosures. Failure to do so may result in delay of service and additional expense. The list of approved enclosures (current at the time of this publication) is provided in **Section VII**. If necessary, the most current list of approved enclosures can be obtained from your local FPL representative or online at <http://www.FPL.com/builder>, using the Electric Service Standards link.

D. Location of Metering Equipment

The metering equipment's location will be designated by an FPL representative. The Customer will provide the meter location free of cost to FPL.

1. Sequence in Service Entrance

Where permitted by Code authorities, the metering equipment will usually precede all service equipment. Customer owned stepdown transformers shall be installed on the load side of the meter. On the City of Miami Downtown Network Grid only, the service equipment should precede the meter.

2. Located Outdoors

Except where meter rooms are used, all metering installations shall be outdoors, on a vertical wall or other substantial support where the view from the ground is unobstructed. They should be readily accessible to FPL at all times so they may be read, inspected, removed or tested with a minimum of disruption of service to the Customer. The preferable height of the centerline of the meter is five feet, six inches above ground. The maximum distance shall be six feet and the minimum five feet, except meter pedestals for mobile homes may have a minimum height of 36".

The meter location should not be affected by a kitchen discharge fan or other vents, or the drain from a roof gutter or air conditioner, and should be free from vibration. Sockets shall be securely attached to the building wall, pedestal, metal rack, or other permanent structure, and aligned so that the meter is both level and plumb (**Fig. IV-7**). Attachment to temporary structures (except for temporary service) or structures subject to early deterioration is prohibited.

When the equipment is exposed to vehicular traffic, FPL may require that the metering equipment be protected by concrete filled 4" steel pipes firmly installed in the ground, similar to those shown in **Fig. V-1**.



Electric Service Standards

DATE
10-24-11

PREPARED BY

SUBJECT

SECTION: PAGE

**Distribution Construction
Processes**

VI. METERING EQUIPMENT

VI - 3 of 17

3. Located Indoors

When meters are located in a meter room, the room should have adequate lighting and contain only meters and associated equipment, and should remain unlocked so meters are readily accessible. In unusual cases where an unlocked meter room would impose a severe hardship on the Customer, arrangements can be made to furnish keys to FPL so the meters will always be accessible to meter readers. The meter room may then be locked, provided this does not violate any local code or rule. The meter room must not be used for storage. The centerline of the meters should be five feet, six inches above the floor, but when necessary because of grouping may be a maximum of 72" and a minimum of 22".

4. Flood Elevation Standards

If local ordinances require meters to be located at or above base flood elevation, the Customer is responsible for providing and maintaining a means of ready access to the meter (for maintenance and reading by FPL personnel). See [Fig. VI-9](#), page 13 of this section for details. Any additional costs incurred by FPL for providing special service to meet the Customer's flood insurance requirements shall be paid by the Customer.

E. Identification of Meters

If a building requires more than one meter, or if the meter is not directly within the boundaries of the premise served, FPL cannot render service until the meter socket or cabinet and the service equipment have been properly marked to show plainly the location served and the character of the service ([Fig. VI-8](#)). Multiple meter sockets shall be "rung out" by the electrical contractor and marked with the appropriate unit numbers before FPL will tap the service and set meters. This marking requirement includes IT rated meter sockets. These markings by the Customer should be plain and permanent, giving the street number to the door of the premise served or the symbol appearing on the entrance door when this door does not carry a street number. The name of the Customer will not suffice for identification. The meter sockets in multi-unit buildings shall be clearly and durably marked.

F. Relocation or Upgrade of Metering Equipment

Whenever it is necessary to relocate or upgrade an existing metering installation, the new installation shall be made by the Customer in accordance with these standards.

A definite schedule for the switch-over to the new meter shall be arranged in advance by the Customer so FPL can accommodate the request upon completion of the Customer's electrical work. The new service entrance shall be inspected and approved by local authorities before service can be restored. No energized service entrance shall be left unmetered, and all meters shall be re-identified as to what units they serve. Refer also to [section III.I](#).

G. Load Profile Metering Requirements

Load Profile Meters may be required when the Customer's load exceeds 500 KWD. Solid State Data Recorders (SSDR) are no longer installed for new services. Load Profile Meters in the form of Recorders-Under-Glass (RUG) or SMART meters are the correct equipment to be installed for all new services. Metering equipment enclosures and associated cabinets are provided and installed by the Customer, typically located near the point of metering at the Customer's service entrance ([Fig. VI-7](#)). Load Profile metering only requires an SJB cabinet if two or more meters are involved in the installation.

The Customer may be required to provide two (2) 3/4" PVC or metallic conduits from the FPL telephone jack cabinet to the point of access to the telephone system. Contact FPL for details.



Electric Service Standards

DATE
10-24-11

PREPARED BY

**Distribution Construction
Processes**

SUBJECT

VI. METERING EQUIPMENT

SECTION: PAGE

VI - 4 of 17

Both RUG and SMART meters provide one channel of Load Profile recording as well as collect data from up to (2) additional pulse-initiating meters. Two or more meters on a Load Profile installation are combined on one account. In addition to basic Load Profile functions, SMART meters provide Power Quality Monitoring and wireless communication capabilities. SMART Meters may require additional cabinets or junction boxes installed to facilitate the antennas required for wireless communications.

H. Installation of FPL's Metering Equipment in Customer's Switchgear

Installation of CTs in customer's switchgear is discouraged and will only be approved if no other location for the CTs is practical. If FPL's equipment is installed in the Customer's switchgear:

1. The installation must be approved by FPL prior to the purchase of the customer's equipment.
2. The customer shall sign a Hold Harmless Agreement absolving FPL of damage to the switchgear during installation or damage caused by failure of the CTs.
3. The CT compartment of the customer's switchgear must comply with FPL's Specification for Customer Owned Instrument Transformer Cabinets, Equipment Enclosures and Junction Boxes Spec. # 6.3.4 (available upon request on an "as needed" basis).
4. The meter enclosure/meter socket must be on FPL's Approved Metering Equipment Enclosure List found in Section VII.
4. The line-side of the conductors in the switchgear must be routed through secured or sealable troughs, conduits, or in such a way to prevent unauthorized taps to be made before the meter.
5. FPL will always provide and install the CTs used in metering the customer.
6. Only FPL approved metering CTs will be used in metering applications.
7. All other rules associated to a proper meter installation (e.g. - meter rings, enclosure covers and meter seals) must be observed.
8. All meter enclosures, cabinets and panels housing FPL equipment must have provisions for sealing.



Electric Service Standards

DATE
10-24-11

PREPARED BY

SUBJECT

SECTION: PAGE

**Distribution Construction
Processes**

VI. METERING EQUIPMENT

VI - 5 of 17

I. Illustrations

- FIG. VI-1:** Metering Configurations - Descriptions and Notes
- FIG. VI-2:** CT Metering Configuration 6 - CTs in Padmounted Transformer or Vault
- FIG. VI-3:** CT Metering Configuration 7, 8, 9 - CT Cabinet Mounted on Wall
- FIG. VI-4:** CT Cabinet and IT Rated Meter Socket - Installation and Bonding
- FIG. VI-5:** CT Metering Configuration 10 - CTs in Weatherhead Cabinet
- FIG. VI-6:** CT Metering Configuration 11 - CTs in Padmounted Primary Metering Cabinet
- FIG. VI-7:** CT Metering Configuration 12 – Load Profile Metering
- FIG. VI-8:** Identification of Multiple Meter Sockets
- FIG. VI-9:** Meter Enclosure Installations in Flood Zones
- FIG. VI-10:** Typical Bus Stub Terminations in Transformer Vaults



FIGURE VI-1
Metering Configurations - Descriptions and Notes

Self Contained Meter Enclosures

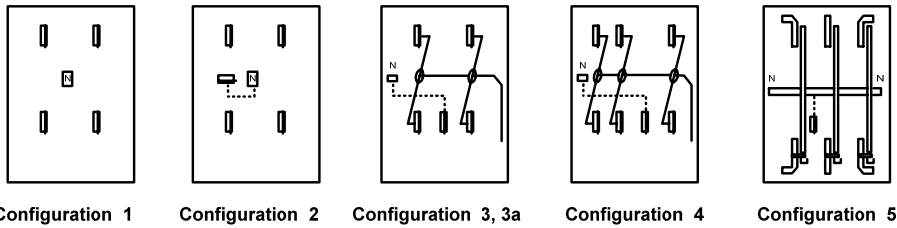

GENERAL NOTES ON SELF CONTAINED METER SOCKET BLOCK CONFIGURATIONS:

- Configuration 1** - Primarily residential applications. Limited to 320 amp demand. (see Note 1 and Note 2)
- Configuration 2** - Modification of Configuration 1 by adding a 5th terminal in the 9 o'clock position. To be used with network meters. Limited to 320 amp demand. (see Note 1 and Note 2)
- Configuration 3** - For one phase service requiring bypass device. Limited to 320 amp demand. (See Note 2)
- Configuration 3a** - Modification of Configuration 3 (5th terminal for network meters). Limited to 320 amp demand. (see Note 2)
- Configuration 4** - For three phase service. Limited to 320 amp demand. (See Note 2)
- Configuration 5** - For one or three phase service. Limited to 600 amp demand. (See Note 3)

- Note 1 - May be used for very small commercial applications, such as billboards, parking lot lights, small pumps and/or pump controllers. Limited to 60 amps for these uses. Consult FPL prior to purchase for commercial uses.
- Note 2 - All three phase and all commercial installations shall have a meter socket with the approved bypass jaw tension/release device (excluding Configuration 5 applications and very small commercial applications referred to in Note 1).
- Note 3 - Maximum wire size is 1-800 MCM or 2-500 MCM per phase. For use on the **LOAD** side, a ridged triple lug is available (Landis & Gyr part #68752-1) that will allow for 3-250 MCM per phase, on the **LOAD** side. For single phase applications leave the center phase unwired.
- Note 4 - In Residential applications where FPL service conductors are paralleled, the customer shall provide and install lugs designed for multiple conductors on the line side of the meter socket.

Current Transformer (CT) Metering

- Configuration 6** - CTs installed within a padmounted transformer or vault with an IT rated meter socket mounted on a pedestal or wall.
- Configuration 7,8** - CTs installed within a wall or pedestal mounted cabinet with an IT rated meter socket. Cabinet size is determined by number and size of conduits and conductors.
- Configuration 9** - CTs mounted within a custom designed and constructed wall mounted cabinet with an IT rated meter socket. This configuration is for conduit and wire combinations that exceed the capacity of the cabinets listed for configuration 8. Refer to FPL Specification 6.3.4 Customer Owned Instrument Transformer Cabinets, Equipment Enclosure & Junction Boxes. **Consult with an FPL representative before designing this configuration.**
- Configuration 10** - CTs mounted within a weather-head cabinet with an IT rated meter socket. This configuration is allowed only when configurations 1-9 are not possible. **Consult with an FPL representative before designing this configuration.**
- Configuration 11** - CTs mounted within a weather-head cabinet with an IT rated meter socket. This configuration is allowed only when configurations 1-9 are not possible. **Consult with an FPL representative before designing this configuration.**
- Configuration 12** - Load Profile metering (RUG & SMART Meters). **Consult with an FPL representative before designing this configuration.**



Electric Service Standards

DATE
10-24-11

PREPARED BY

SUBJECT

SECTION: PAGE

Distribution Construction Processes

VI. METERING EQUIPMENT

VI - 7 of 17

**FIGURE VI-2
CT Metering Configuration 6 - CTs in Padmounted Transformer or Vault**

1. IT rated meter socket provided and installed by customer: ___ 1ph or ___ 3ph (check one)
2. Current transformers (CTs) provided and installed in padmounted transformer by FPL.
3. 1-1/2" minimum rigid galvanized conduit with pull string installed (with bushings) or 1-1/2" minimum Schedule 80 PVC conduit with pull string installed between meter socket and padmounted transformer provided and installed by customer. Condulets are **NOT** allowed, and limited to 2 - 90 degree bends per run. **For maximum distance between transformer and socket, see table below.**
4. Restricted to one customer per padmounted transformer. Exceptions **must** be approved by FPL.
5. CT ratio determined by FPL.

CT Ratio		Max Amps	Max Distance (feet)	Max Cable length (feet)
✓	Ratio			
	300/5	600	10	20
	600/5	1200	40	50
	1200/5	2400	40	50
	2000/5	3000	40	50

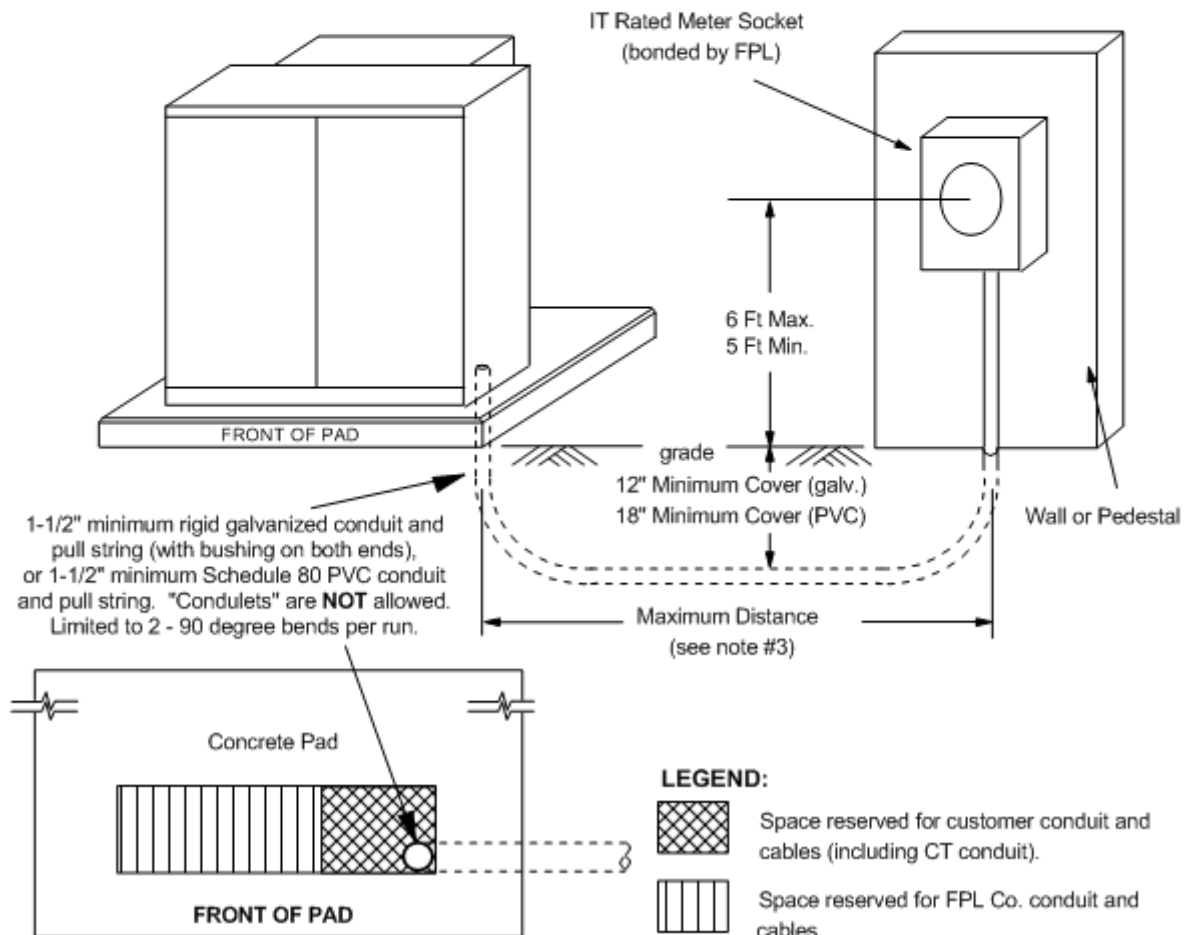
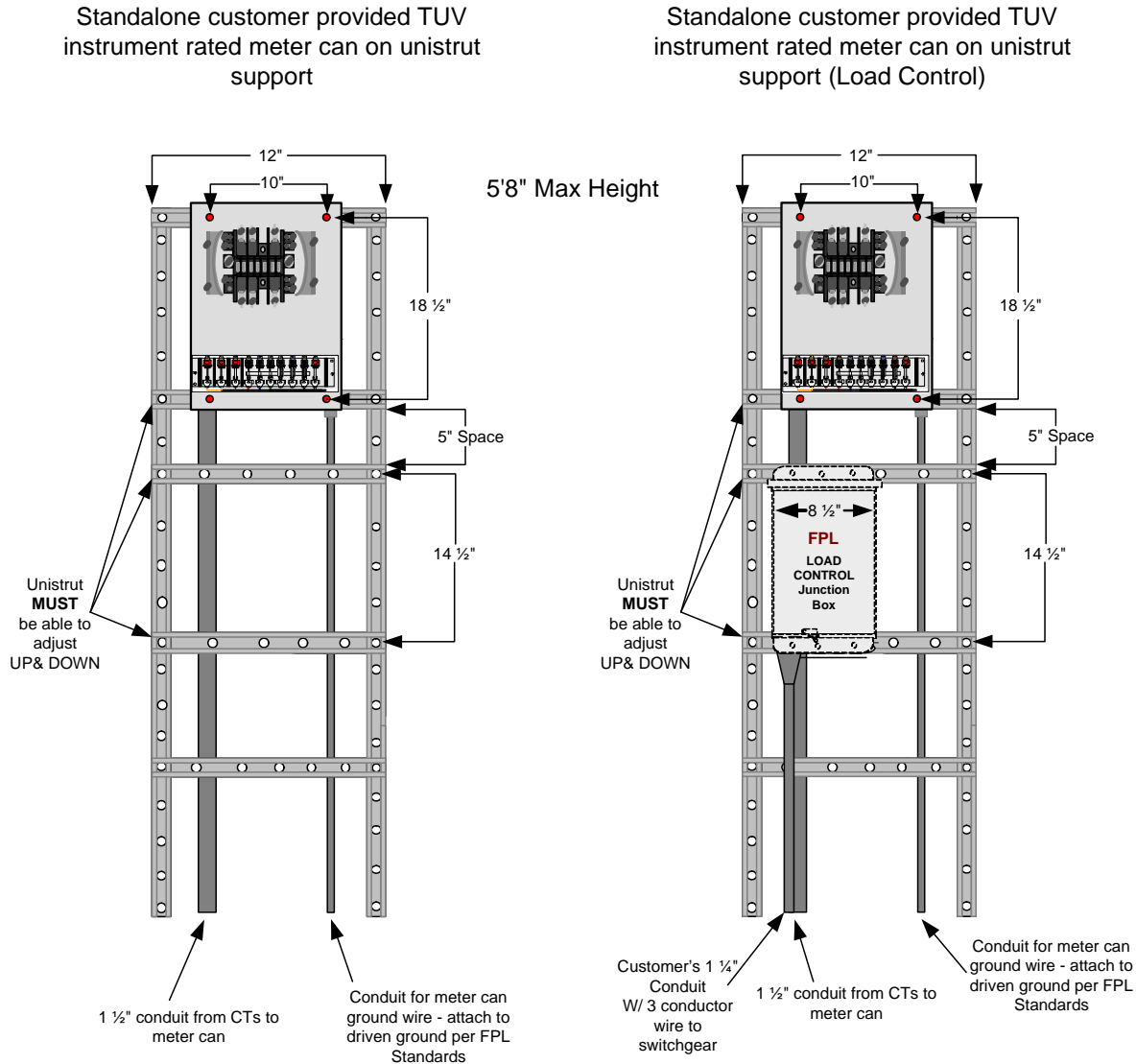

FIGURE VI-2a
Unistrut mounting for Instrument Rated TUV meter cans (CT metering)



- 1) Metercans Face Away From the TX.
- 2) Bury unistrut in ground minimum 3 feet in compacted earth, or 2 feet if encased in concrete
- 3) When applicable, FPL provides and installs the Load Control Junction Box (LCJB)
- 4) Unistrut Requirements:
 - A. Unistrut - Per ASTM Spec. A-123 or A-153, 1-5/8 x 1-5/8", 12 ga., 9/16" dia. Holes spaced 1- 7/8" apart
 - B. To connect the Unistrut Framing use:
 - 3/8 x 1-1/4" electrogalvanized bolts, per ASTM A164
 - Nut w/ spring for 3/8 dia. bolt, electrogalvanized, per ASTM A164
 - Flat Washer - 1" dia. for 3/8" bolt, electrogalvanized, per ASTM A164
 - Lock Washer - for 3/8" dia. bolt, hot-dipped galvanized, per ASTM A153
 - C. To attach cabinets and boxes use:
 - 1/4" x 20 electrogalvanized bolts, per ASTM A164
 - Nut w/ spring for 1/4" dia. bolt, electrogalvanized, per ASTM A164



Electric Service Standards

DATE
10-24-11

PREPARED BY

SUBJECT

SECTION: PAGE

Distribution Construction Processes

VI. METERING EQUIPMENT

VI - 9 of 17

**FIGURE VI-3
CT Metering Configuration 7, 8, 9 - CT Cabinet Mounted on Wall**

1. IT rated meter socket provided and installed by customer: ___ 1ph or ___ 3ph (check one)
2. Wall mounted current transformer (CT) cabinet provided and installed by customer.
3. 1-1/2" minimum rigid galvanized conduit with pull string installed (with bushings) or 1-1/2" minimum Schedule 80 PVC conduit with pull string installed between meter socket and current transformer cabinet provided and installed by customer. Maximum 2 - 90 degree bends. **Maximum allowed distance from socket to cabinet is 40 feet.**
4. Window CTs provided by FPL and installed in the CT cabinet by the customer before pulling wire. Ensure CTs are installed in the correct orientation (indicator dot toward the source).
5. Customer's conductor(s) must run continuous through the transformer cabinet.
6. Size and number of conductors entering **shall** equal the size and number of conductors exiting.
7. Conduits/Cables must enter/exit opposing corners (AA/AA or BB/BB) as indicated below within 10" of the cabinet's corner and **must** be approved by FPL **before** installation.
8. Configuration 9 is for conduit / wire combinations exceeding the limits of Configuration 8. The cabinet will be custom designed and built to FPL specifications by the customer. **Contact FPL before specifying this configuration.**
9. For general installation and bonding details, refer to **Figure VI-4 "CT Cabinet and IT Rated Meter Socket Installation and Bonding"**

MAXIMUM CONDUCTOR SIZE AND NUMBER			
Conf	Wires per phase	Size Copper MCM	Size Alum MCM
7	2	600	400
8	4	600	400
9	custom designed		

MAXIMUM CONDUIT SIZE AND NUMBER			
Conf	Conduit size	# Conduits entering	# Conduits exiting
7	4"	2	2
8	4"	4	4
9	per customer requirements		

CT RATIO	MAX AMPS
✓ 300/5	600
600/5	1200
1200/5	2400
2000/5	3000
4000/5	6000

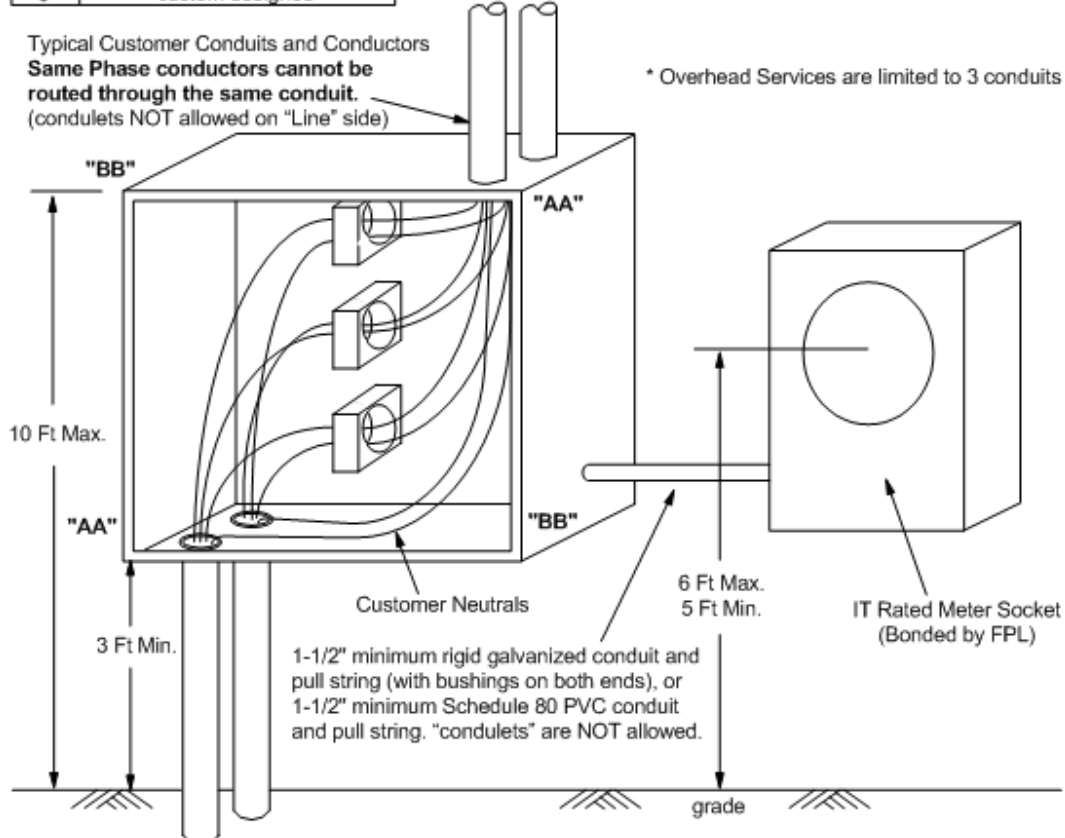

**FIGURE VI-4
CT Cabinet and IT Rated Meter Socket - Installation and Bonding**

FPL Will:

1. Furnish and install the IT rated meter socket bonding wire.
2. Furnish and install the instrument transformers, the wiring from the transformer secondary to the meter, and set the meter.

The Customer Will:

1. Furnish and install the service entrance conduit, conductors, and equipment, including grounds.
2. Furnish and install the IT rated meter socket, current transformer cabinet (when required), and equipment enclosures (when required).
3. Furnish and install any conduit necessary to connect the cabinets and sockets including a pull string.
4. Mount cabinet with sealing ears at bottom.
5. Fasten cabinet and meter socket to masonry walls with toggle screws or expansion shields (no plastic plugs or impact tools).
6. When cabinet is installed in exposed locations, install conduits entering top of cabinet with approved watertight connectors.
7. Installations must conform to local code requirements.
8. Furnish and install bonding jumpers from service disconnect equipment to current transformer cabinet.

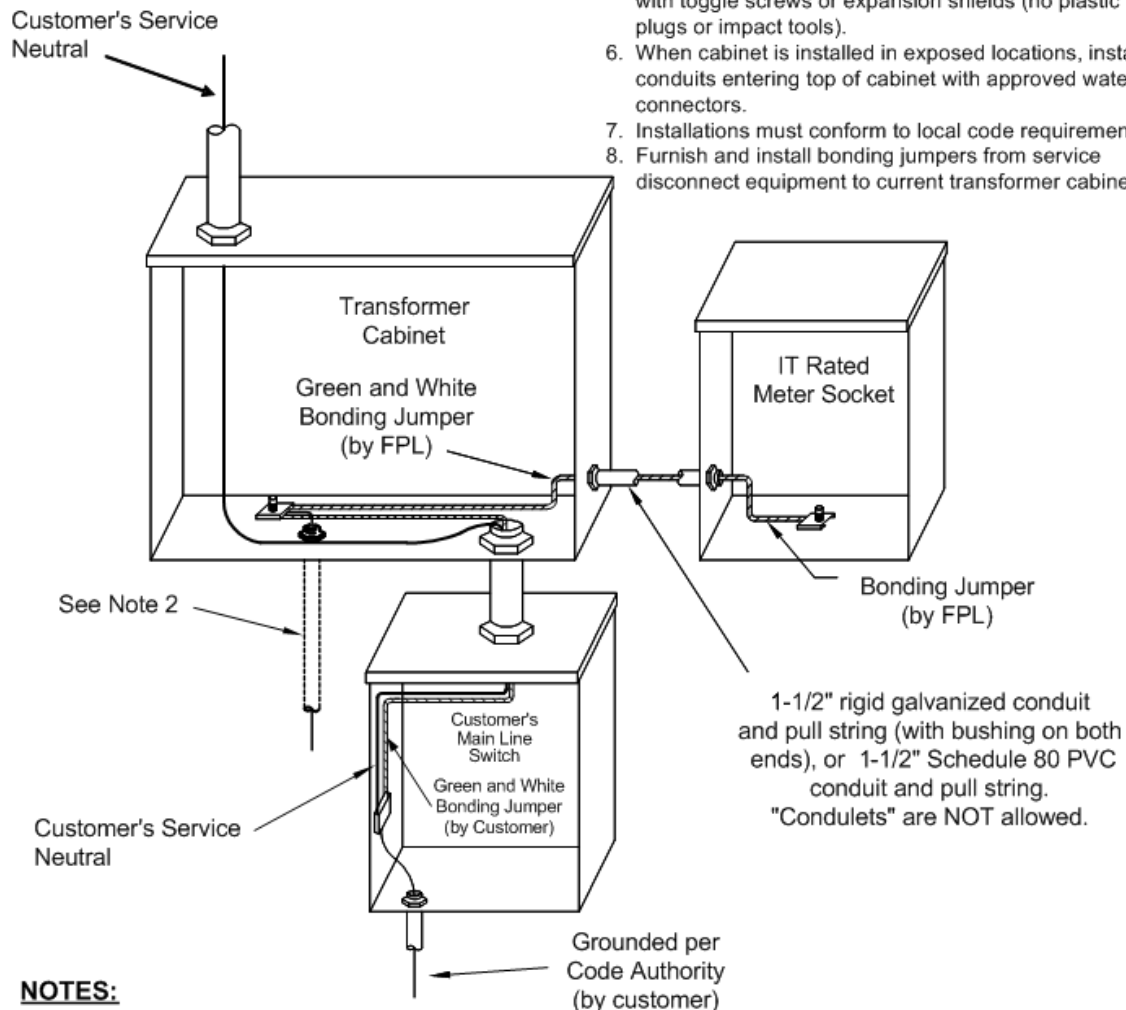

NOTES:

1. All IT rated meter sockets and current transformer cabinets to be bonded with #12C bonding jumper (green with white stripe) by FPL. Customer's service disconnect equipment to be bonded to current transformer cabinet with #12C bonding jumper (green with white stripe) by the customer.
2. If the IT rated meter socket or transformer cabinet is mounted on a utility pole, then it is to be grounded per FPL distribution standards.
3. Customer's conductor(s) must be continuous through the transformer cabinet.



Electric Service Standards

DATE
10-24-11

PREPARED BY
Distribution Construction Processes

SUBJECT
VI. METERING EQUIPMENT

SECTION: PAGE
VI - 11 of 17

**FIGURE VI-5
CT Metering Configuration 10 - CTs in Weatherhead Cabinet**

USED FOR MAINTENANCE ONLY (Not intended for new installations)

1. IT rated meter socket provided and installed by customer: ___ 1ph or ___ 3ph (check one)
2. Weatherhead transformer cabinet provided and installed by customer.
3. 1-1/2" minimum rigid galvanized conduit with pull string installed (with bushings) or 1-1/2" minimum Schedule 80 PVC conduit with pull string installed between meter socket and current transformer cabinet provided and installed by customer. **Maximum allowed distance between socket and cabinet is 40 feet.**
4. Customer to provide and install watertight "Myers type" conduit connector when conduit enters top of IT rated meter socket.
5. Window CTs provided and installed in transformer cabinet by FPL after cabinet is mounted by customer.
6. FPL service cable will pass through CTs unless otherwise approved by FPL.
7. This configuration is allowed **only** when no other configuration is possible, or practical, and **must** be approved by FPL. **Contact FPL before specifying this configuration.**
8. For general installation and bonding details, refer to FPL sheet entitled "Current Transformer Cabinet and IT Rated Meter Socket Installation and Bonding"

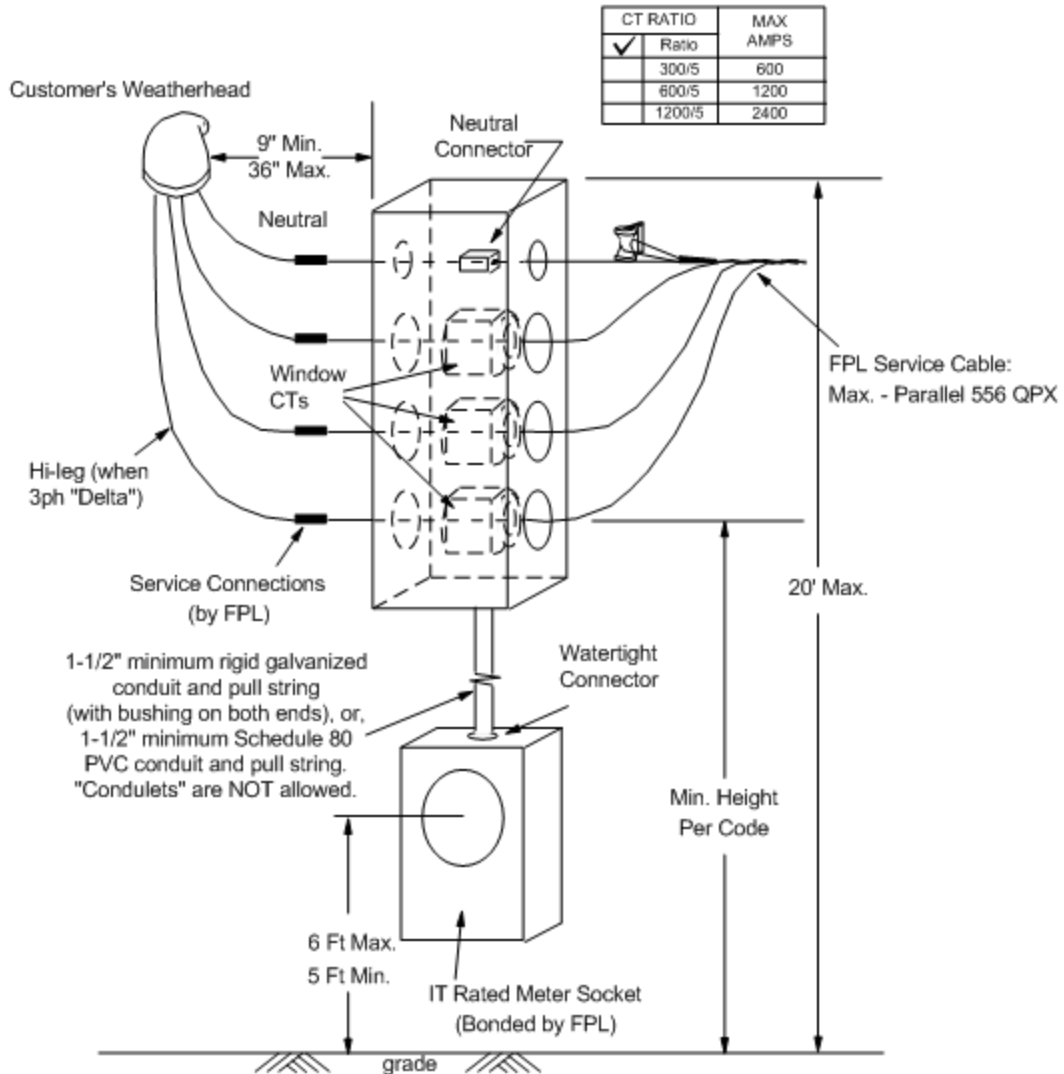
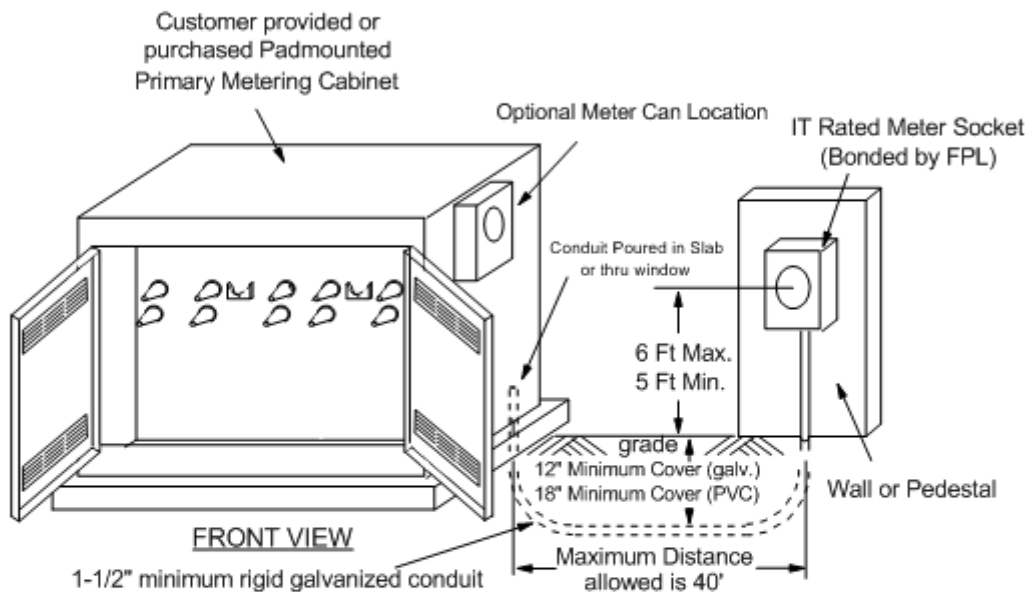



FIGURE VI-6
CT Metering Configuration 11 - CTs in Padmounted Primary Metering Cabinet

1. IT rated meter socket provided and installed by customer: ___ 1ph or ___ 3ph (check one)
2. Padmounted primary metering cabinet and concrete pad provided or purchased and installed by customer.
3. 1-1/2" minimum rigid galvanized conduit (with bushings) or 1-1/2" minimum Schedule 80 PVC conduit between meter socket and padmounted metering cabinet. Install pull string in the conduit. Maximum of 2-90 degree bends allowed. **Maximum allowed distance between padmounted metering cabinet and meter socket is 40 feet.**
4. Primary (4KV, 13KV, 23KV) current and voltage transformers provided and installed by FPL.
5. This configuration's application is limited and requires close coordination. **Consult with an FPL representative before designing this configuration.**



1-1/2" minimum rigid galvanized conduit and pull string (with bushing on both ends), or 1-1/2" minimum Schedule 80 PVC conduit and pull string. "Condulets" are NOT allowed. Maximum of 2-90 degree bends.

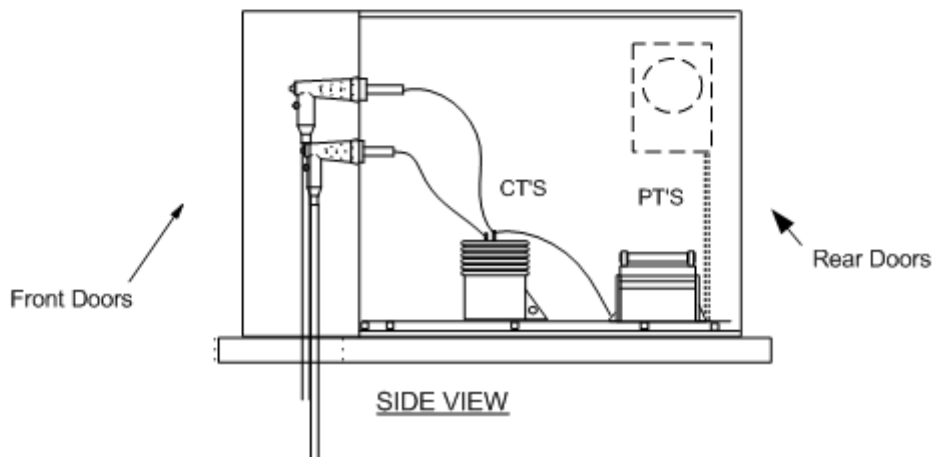
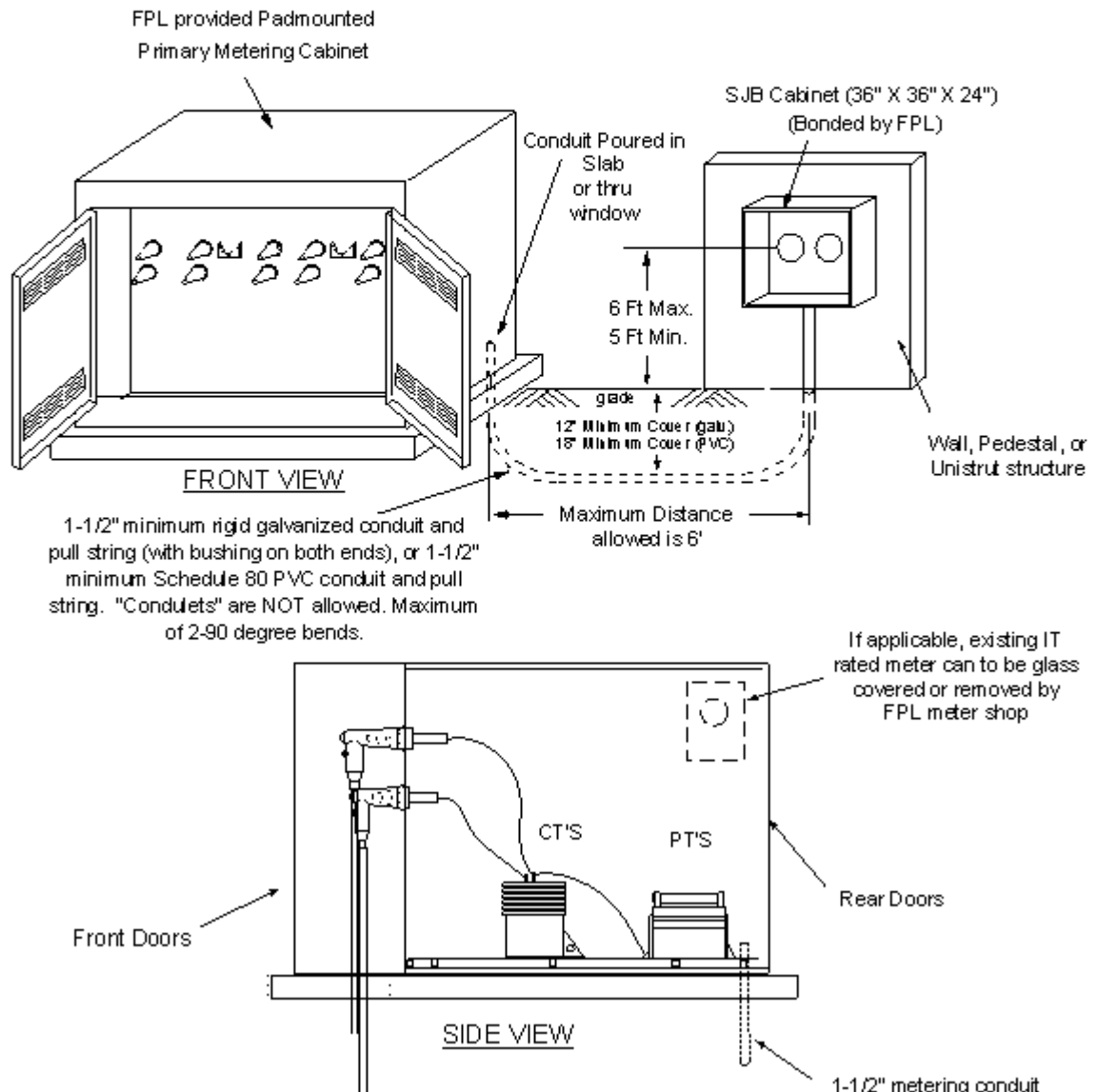



FIGURE VI-6a
CT Metering Configuration 11 – Renewable Generation ONLY

1. SJB Cabinet provided by FPL, installed by customer. Fasten cabinet to masonry walls with toggle screws or expansion shields (no plastic anchors or impact tools).
2. Padmounted primary metering cabinet and concrete pad provided by FPL and installed by customer.
3. 1-1/2" minimum rigid galvanized conduit (with bushings) or 1-1/2" minimum Schedule 80 PVC conduit between meter socket and padmounted metering cabinet. Install pull string in the conduit. Maximum of 2-90 degree bends allowed. **Maximum allowed distance between padmounted metering cabinet and meter socket is 6 feet.**
4. Primary (4KV, 13KV, 23KV) current and voltage transformers provided and installed by FPL.
5. This configuration's application is limited and requires close coordination. **Consult with an FPL representative before designing this configuration.**





**FIGURE VI-8
Identification of Multiple Meter Sockets**

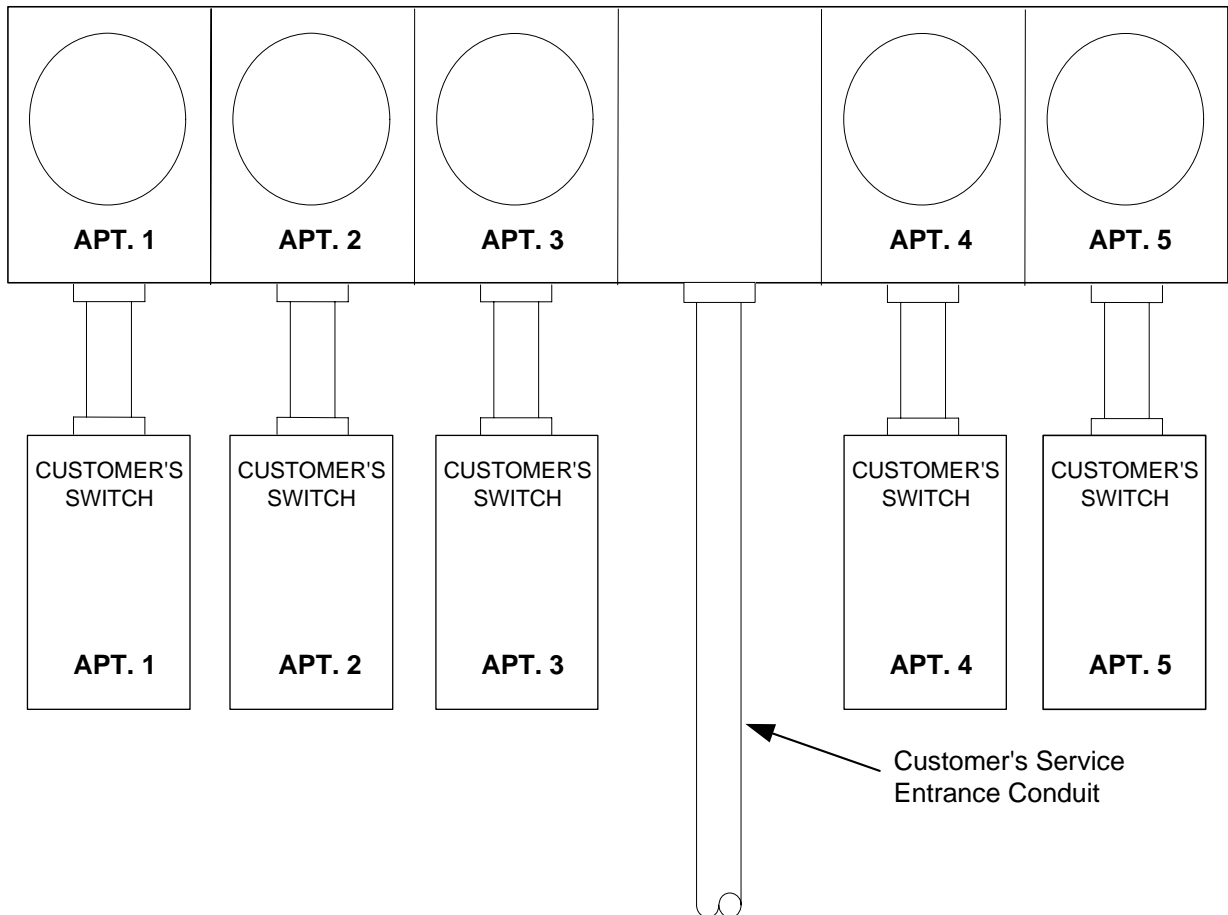

Customer to mark meter socket and switch covers with paint or other permanent durable marker to identify premises served. Markings should also be put inside meter socket (to prevent confusion if covers are interchanged before service is connected). If living units have different house numbers, these should be shown in place of apartment numbers. IT rated meter sockets (not illustrated) should be marked similarly.

The Electrical Contractor shall provide FPL a meter layout drawing.



FIGURE VI-9
Meter Enclosure Installations in Flood Zones

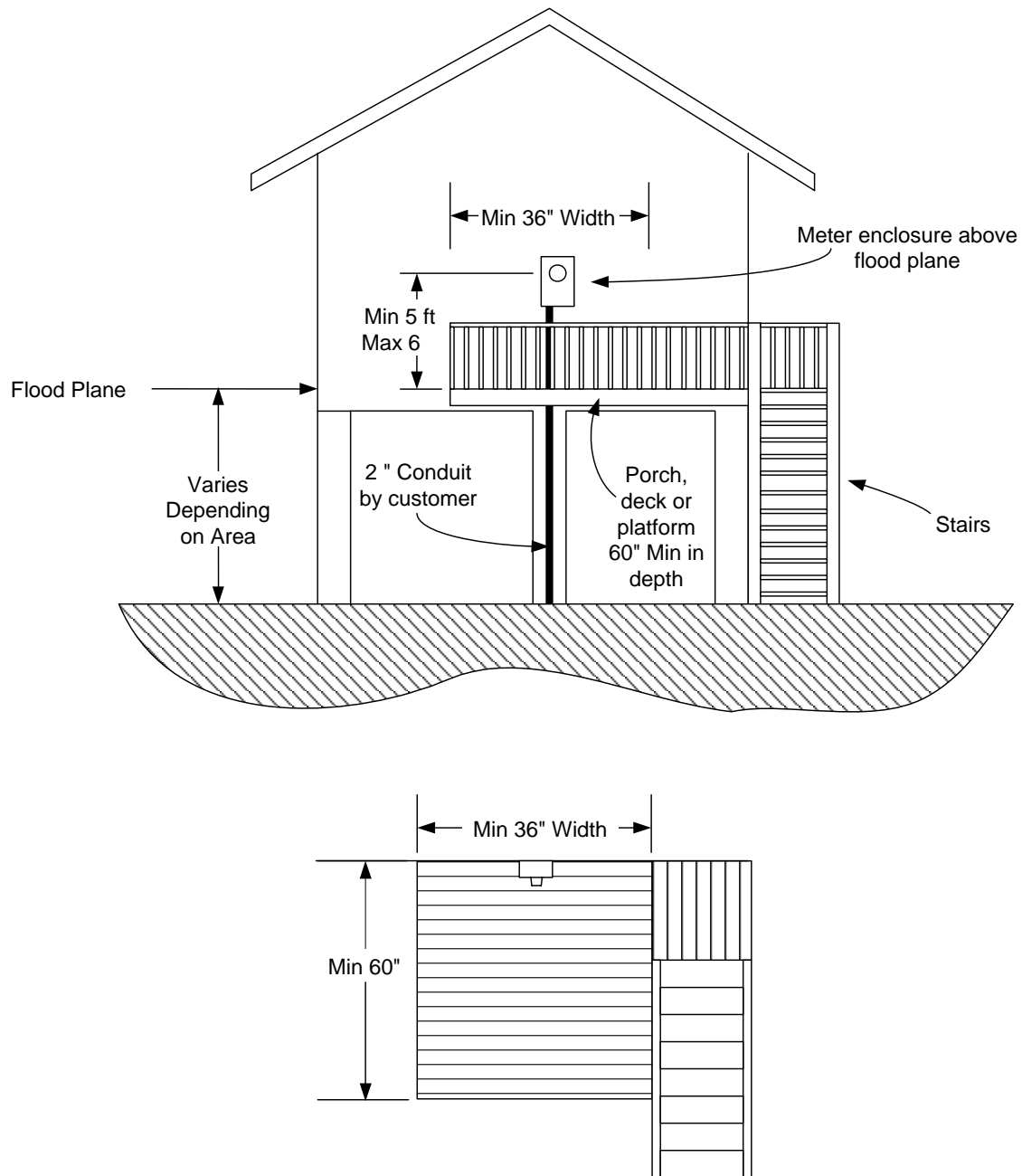

Note:

When elevation of the meter enclosure is required by the authority having jurisdiction, the permanent installation of deck/platform and stairs shall be installed and provided by customer prior to energizing the facility.

**FIGURE VI-10
Typical Bus Stub Terminations in Transformer Vaults**

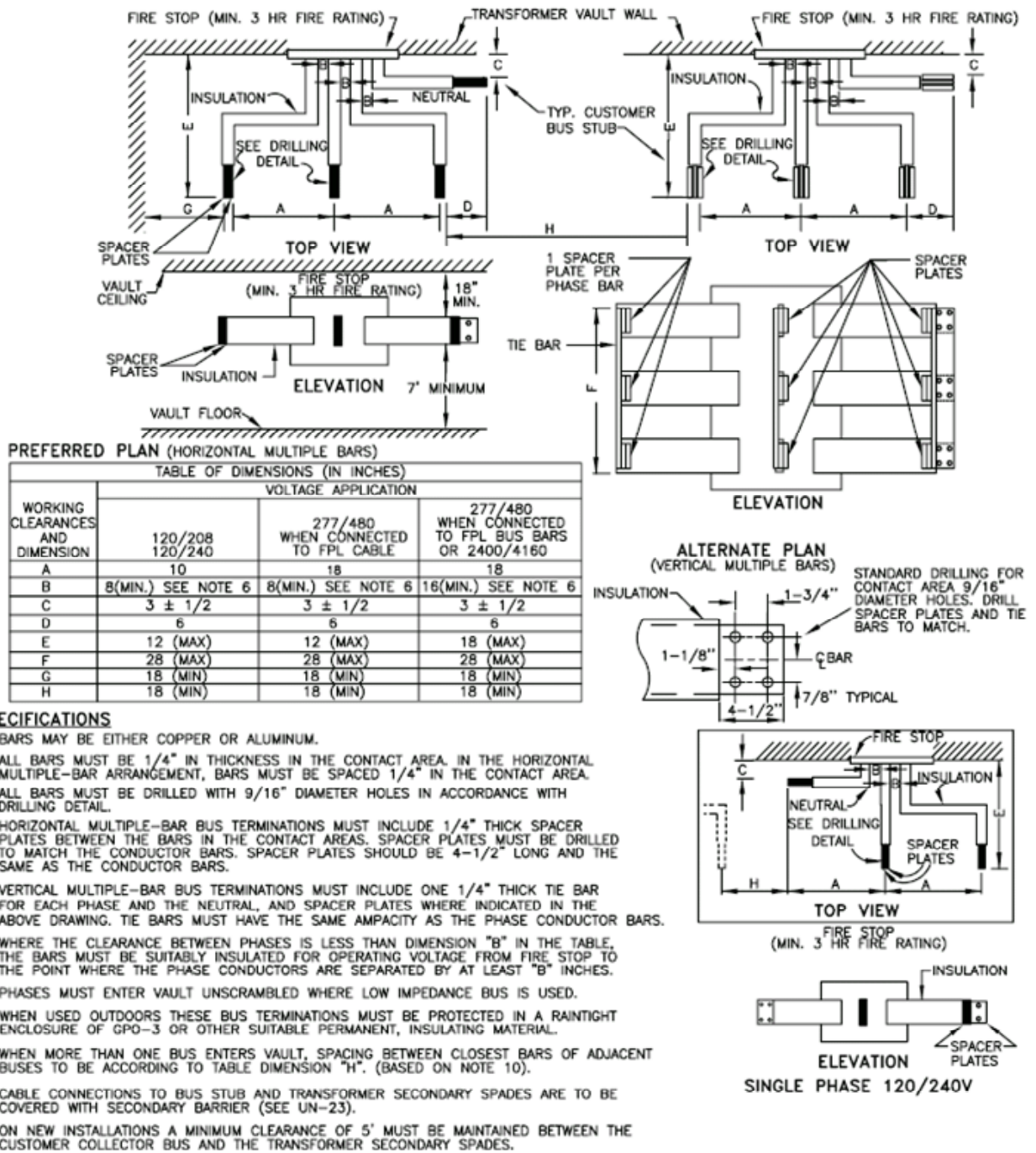

SPECIFICATIONS

1. BARS MAY BE EITHER COPPER OR ALUMINUM.
2. ALL BARS MUST BE 1/4" IN THICKNESS IN THE CONTACT AREA. IN THE HORIZONTAL MULTIPLE-BAR ARRANGEMENT, BARS MUST BE SPACED 1/4" IN THE CONTACT AREA.
3. ALL BARS MUST BE DRILLED WITH 9/16" DIAMETER HOLES IN ACCORDANCE WITH DRILLING DETAIL.
4. HORIZONTAL MULTIPLE-BAR BUS TERMINATIONS MUST INCLUDE 1/4" THICK SPACER PLATES BETWEEN THE BARS IN THE CONTACT AREAS. SPACER PLATES MUST BE DRILLED TO MATCH THE CONDUCTOR BARS. SPACER PLATES SHOULD BE 4-1/2" LONG AND THE SAME AS THE CONDUCTOR BARS.
5. VERTICAL MULTIPLE-BAR BUS TERMINATIONS MUST INCLUDE ONE 1/4" THICK TIE BAR FOR EACH PHASE AND THE NEUTRAL, AND SPACER PLATES WHERE INDICATED IN THE ABOVE DRAWING. TIE BARS MUST HAVE THE SAME AMPACITY AS THE PHASE CONDUCTOR BARS.
6. WHERE THE CLEARANCE BETWEEN PHASES IS LESS THAN DIMENSION "B" IN THE TABLE, THE BARS MUST BE SUITABLY INSULATED FOR OPERATING VOLTAGE FROM FIRE STOP TO THE POINT WHERE THE PHASE CONDUCTORS ARE SEPARATED BY AT LEAST "B" INCHES.
7. PHASES MUST ENTER VAULT UNSCRAMBLED WHERE LOW IMPEDANCE BUS IS USED.
8. WHEN USED OUTDOORS THESE BUS TERMINATIONS MUST BE PROTECTED IN A RAINIGHT ENCLOSURE OF GPO-3 OR OTHER SUITABLE PERMANENT, INSULATING MATERIAL.
9. WHEN MORE THAN ONE BUS ENTERS VAULT, SPACING BETWEEN CLOSEST BARS OF ADJACENT BUSES TO BE ACCORDING TO TABLE DIMENSION "H". (BASED ON NOTE 10).
10. CABLE CONNECTIONS TO BUS STUB AND TRANSFORMER SECONDARY SPADES ARE TO BE COVERED WITH SECONDARY BARRIER (SEE UN-23).
11. ON NEW INSTALLATIONS A MINIMUM CLEARANCE OF 5' MUST BE MAINTAINED BETWEEN THE CUSTOMER COLLECTOR BUS AND THE TRANSFORMER SECONDARY SPADES.

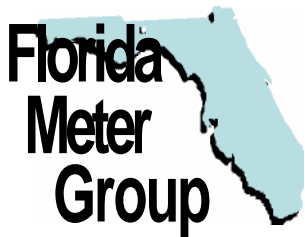

Approved Meter Equipment Enclosure List:

Revised
7/1/2011

The attached list of self-contained meter sockets and enclosures has been approved for use in the service areas served by the utilities of the Florida Meter Group. Approval is based on the unit's compliance with the FMG specifications, particularly U.L. listing, sealing requirements, bypass characteristics, and certain operational concerns. FMG makes no claims regarding nameplate ratings or load side attachments beyond the sealed portion of the meter socket. We recommend that all units be used as intended by the manufacturer. All additional data is supplied for informational purposes only.

NOTES:

- A. All commercial or three phase applications require a unit with an approved bypass device. (Configuration 3, 4 or 5)
- B. All 320/400 Amp enclosures are 400 Amp rated
- C. Aluminum enclosures are recommended in salt spray areas.
- D. Sealing rings (ring-type sockets) along with all lugs/connectors (line and load side) are considered to be part of the meter enclosure. The customer/contractor is thereby responsible for furnishing these items. Please contact your utility representative to determine the proper size lugs/connectors. The sealing ring must be a captive-screw type equivalent to ABB #01 L0028G02, Milbank MR-4, Landis & Gyr #9738-8002, or Ekstrom 10-9090.
- E. The "configuration" refers to the various meter connecting arrangements used to accommodate the utility meter. These configurations are described below:

FMG SELF CONTAINED

<u>CONFIGURATIONS</u>	<u>DESCRIPTION & TYPICAL APPLICATION</u>
1	Residential - 4 Terminal Socket, Single Phase, 3 Wire
2	Residential - 5 Terminal Socket, Network, 3 Wire
3	Residential/Commercial - 4 Terminal Socket (w/Bypass), Single Phase, 3 Wire
3a	Residential/Commercial - 5 Terminal Socket (w/Bypass), Network, 3 Wire
4	Commercial - 7 Terminal Socket (w/Bypass), Three Phase, 4 Wire
5	Residential/Commercial – K7 Base (w/Bypass), Single Phase (FPL Only), Three Phase or Network, 3 or 4 Wire
*5a	Residential/Commercial – K4 Base (w/Bypass), Single Phase (TECO Only).

FPL IT RATED

<u>CONFIGURATIONS</u>	<u>DESCRIPTION & TYPICAL APPLICATION</u>
6	CTs installed within a padmounted transformer or vault with an IT rated meter socket mounted on a pedestal or wall.
7,8	CTs installed within a wall or pedestal mounted cabinet with an IT rated meter socket. Cabinet size determined by number and size on conduits and conductors.
9	CTs mounted within a customer designed and constructed wall mounted cabinet with an IT rated meter socket. This configuration is for conduit and wire combinations that exceed the capacity of the cabinets listed for configuration 8. Consult with an FPL Representative before designing this configuration.
10	CTs mounted within a weather-head cabinet with an IT rated meter socket. This configuration is allowed only when configurations 1-9 are not possible.
11	Primary Metering within an underground area.
12	Solid State Data Receiver (SSDR) metering.
13	Utility Meter Cabinet for general metering use.



Approved Metering Equipment Enclosure List

Revised
7/1/2011

Manufacturer	Amps	Catalog Number	Phase	Service	Pos	Term	Bypass	Config
Durham	100	UTZ-6R1 13 1C-FL	1	Ov/Un	6	5	N	1,2
Durham	100	UTZ-xR1 12 1C-FL	(where x=2-5)	1	Ov/Un	2-5	4/5	N 1,2
Durham	125	UATZ-RS101C-FL	1	Ov/Un	1	4/5	N	1,2 AI
Durham	125	UTZ-RS101C-FL	1	Ov/Un	1	4/5	N	1,2
Durham	200	UAT-H4203x-FL	(where x=B or T)	1	Over	1	4	Y 1 AI
Durham	200	UAT-H4213x-FL	(where x=C or U)	1	Ov/Un	1	4	Y 1 AI
Durham	200	UAT-H5203x-FL	(where x=B or T)	1	Over	1	5	Y 3,3a AI
Durham	200	UAT-H5213x-FL	(where x=C or U)	1	Ov/Un	1	5	Y 3,3a AI
Durham	200	UAT-H7203x-FL	(where x=B or T)	3	Over	1	7	Y 4 AI
Durham	200	UAT-H7213x-FL	(where x=C or U)	3	Ov/Un	1	7	Y 4 AI
Durham	200	UAT-RS202B-FL	1	Over	1	4/5	N	1,2 AI
Durham	200	UAT-RS212C-FL	1	Ov/Un	1	4/5	N	1,2 AI
Durham	200	UAT-RS213A-FL	1	Under	1	4/5	N	1,2 AI
Durham	200	UAT-RS213C-FL	1	Ov/Un	1	4/5	N	1,2 AI
Durham	200	UAT-RS223A-FL	1	Under	1	4/5	N	1,2 AI
Durham	200	UT-4R2352U-FL	1	Ov/Un	4	4/5	N	1,2
Durham	200	UT-H4203x-FL	(where x=B or T)	1	Over	1	4	Y 1
Durham	200	UT-H4213x-FL	(where x=C or U)	1	Ov/Un	1	4	Y 1
Durham	200	UT-H5203x-FL	(where x=B or T)	1	Over	1	5	Y 3,3a
Durham	200	UT-H5213x-FL	(where x=C or U)	1	Ov/Un	1	5	Y 3,3a
Durham	200	UT-H7203x-FL	(where x=B or T)	3	Over	1	7	Y 4
Durham	200	UT-H7213x-FL	(where x=C or U)	3	Ov/Un	1	7	Y 4
Durham	200	UT-RS202B-FL	1	Over	1	4/5	N	1,2
Durham	200	UT-RS212C-FL	1	Ov/Un	1	4/5	N	1,2
Durham	200	UT-RS213A-FL	1	Under	1	4/5	N	1,2
Durham	200	UT-RS213C-FL	1	Ov/Un	1	4/5	N	1,2
Durham	200	UT-RS223A-FL	1	Under	1	4/5	N	1,2
Durham	200	UT-xR2332U-FL	(where x=2-3)	1	Ov/Un	2-3	4/5	N 1,2
Durham	200	UT-xR2392UU-FL	(where x=5-6)	1	Ov/Un	5-6	4/5	N 1,2
Durham	400	1008836	1	Ov/Un	1	4	Y	1
Durham	400	1008837	1	Ov/Un	1	4	Y	1 AI
Durham	400	UAT-H4300T-FL	1	Over	1	4	Y	1 AI
Durham	400	UAT-H5300T-FL	1	Over	1	5	Y	3,3a AI
Durham	400	UAT-H5330U-FL	1	Ov/Un	1	5	Y	3,3a AI
Durham	400	UAT-H7300T-FL	3	Over	1	7	Y	4 AI
Durham	400	UAT-H7330U-FL	3	Ov/Un	1	7	Y	4 AI
Durham	400	UT-H4300T-FL	1	Over	1	4	Y	1
Durham	400	UT-H5300T-FL	1	Over	1	5	Y	3,3a
Durham	400	UT-H5330U-FL	1	Ov/Un	1	5	Y	3,3a
Durham	400	UT-H7300T-FL	3	Over	1	7	Y	4



Participants: FPL, GULF, PEF, TECO

Approved Metering Equipment Enclosure List

Revised
7/1/2011

Manufacturer	Amps	Catalog Number	Phase	Service	Pos	Term	Bypass	Config
Durham	400	UT-H7330U-FL	3	Ov/Un	1	7	Y	4
Eaton-Cutler Hammer	100	UTZ-6R1 13 1C-FLCH	1	Ov/Un	6	4/5	N	1,2
Eaton-Cutler Hammer	100	UTZ-xR1121C-FLCH (where x=2-5)	1	Ov/Un	2-5	4/5	N	1,2
Eaton-Cutler Hammer	125	1MMx12RRL or RRLC (where x=3-6)	1	Ov/Un	3-6	4	N	1,2
Eaton-Cutler Hammer	125	1MP2122RRL or RRLC	1	Ov/Un	2	4	N	1,2
Eaton-Cutler Hammer	125	1MPx124RRL or RRLC (where x=3-4)	1	Ov/Un	3	4	N	1,2
Eaton-Cutler Hammer	125	1MPx126RRL or RRLC (where x=5-6)	1	Ov/Un	5-6	4	N	1,2
Eaton-Cutler Hammer	125	3MMx12RRL or RRLC (where x=2-6)	3	Ov/Un	2-6	4	N	1,2
Eaton-Cutler Hammer	125	CHR (POWER OUTLET PANEL)	1	Ov/Un	1	4	N	1,2
Eaton-Cutler Hammer	125	CMB24L125BTS FLCH	1	Ov/Un	1	4/5	N	1,2
Eaton-Cutler Hammer	125	MB24L125BTS FLCH	1	Ov/Un	1	4/5	N	1,2
Eaton-Cutler Hammer	125	UATZ-RS101C-FLCH	1	Ov/Un	1	4/5	N	1,2 AI
Eaton-Cutler Hammer	125	UTZ-RS101C-FLCH	1	Ov/Un	1	4/5	N	1,2
Eaton-Cutler Hammer	150	CMB88B150BTS FLCH	1	Ov/Un	1	4	N	1,2
Eaton-Cutler Hammer	150	CMBB150BTS FLCH	1	Ov/Un	1	4/5	N	1,2
Eaton-Cutler Hammer	150	MB816B150BTS FLCH	1	Ov/Un	1	4	N	1,2
Eaton-Cutler Hammer	200	1MMx20RRL or RRLC (where x=3-4)	1	Ov/Un	3-4	4/5	N	3,3a
Eaton-Cutler Hammer	200	1MP2204RRL or RRLC	1	Ov/Un	2-6	4	N	1,2
Eaton-Cutler Hammer	200	1MPx206RRL or RRLC (where x=3-6)	1	Ov/Un	2-6	4	N	1,2
Eaton-Cutler Hammer	200	3MMx20RRL or RRLC or R12RL (where x=2-4)	1	Ov/Un	2-4	5	N	3,3a
Eaton-Cutler Hammer	200	CMB1212B200BTS FLCH	1	Ov/Un	1	4/5	N	1
Eaton-Cutler Hammer	200	CMB1212L200BTS	1	Ov/Un	1	4	N	1,2
Eaton-Cutler Hammer	200	CMB1212P200BTS FLCH	1	Ov/Un	1	4	N	1,2
Eaton-Cutler Hammer	200	CMB4242B200BTS FLCH	1	Ov/Un	1	4	N	1,2
Eaton-Cutler Hammer	200	CMB88B200BTS FLCH	1	Ov/Un	1	4	N	1,2
Eaton-Cutler Hammer	200	CMBB200BTS FLCH	1	Ov/Un	1	4	N	1,2
Eaton-Cutler Hammer	200	CMBP200BTS FLCH	1	Ov/Un	1	4	N	1,2
Eaton-Cutler Hammer	200	MB1212L200BTS	1	Ov/Un	1	4/5	N	1,2
Eaton-Cutler Hammer	200	MB1212L200BTS A	1	Ov/Ln	1	4/5	N	1,2 AI
Eaton-Cutler Hammer	200	MB2040B200BTS FLCH	1	Ov/Un	1	4	N	1,2
Eaton-Cutler Hammer	200	MB2040P200BTS FLCH	1	Ov/Un	1	4/5	N	1
Eaton-Cutler Hammer	200	MB48B200BTS FLCH	1	Ov/Un	1	4	N	1,2
Eaton-Cutler Hammer	200	MB816B200BTS FLCH	1	Ov/Un	1	4	N	1,2
Eaton-Cutler Hammer	200	MB816P200BTS FLCH or BTSCU FLCH	1	Ov/Un	1	4/5	N	1
Eaton-Cutler Hammer	200	MBB150BTS FLCH	1	Ov/Un	1	4	N	1,2
Eaton-Cutler Hammer	200	MBB200BTS FLCH	1	Ov/Un	1	4	N	1,2
Eaton-Cutler Hammer	200	MBP200BTS FLCH	1	Ov/Un	1	4	N	1,2
Eaton-Cutler Hammer	200	MBT48B200BTS	1	Ov/Un	1	4/5	N	1,2
Eaton-Cutler Hammer	200	MC1212L200BTS A	1	Ov/Un	1	4/5	N	1,2 AI



Approved Metering Equipment Enclosure List

Revised
7/1/2011

P - 0 - 1 -

Manufacturer	Amps	Catalog Number		Phase	Service	Pos	Term	Bypass	Config
Eaton-Cutler Hammer	200	UAT-H4203x-FLCH	(where x=B or T)	1	Over	1	4	Y	1 AI
Eaton-Cutler Hammer	200	UAT-H5203x-FLCH	(where x=B or T)	1	Over	1	5	Y	3,3a AI
Eaton-Cutler Hammer	200	UAT-H7203x-FLCH	(where x=B or T)	3	Over	1	7	Y	4 AI
Eaton-Cutler Hammer	200	UAT-RS202B-FLCH		1	Over	1	4/5	N	1,2 AI
Eaton-Cutler Hammer	200	UAT-RS212C-FLCH		1	Ov/Un	1	4/5	N	1,2 AI
Eaton-Cutler Hammer	200	UAT-RS213A-FLCH		1	Under	1	4/5	N	1,2 AI
Eaton-Cutler Hammer	200	UAT-RS213C-FLCH		1	Ov/Un	1	4/5	N	1,2 AI
Eaton-Cutler Hammer	200	UAT-RS223A-FLCH		1	Under	1	4/5	N	1,2 AI
Eaton-Cutler Hammer	200	UAT-y4213x-FLCH	(where y=E or H, where x=C or U)	1	Ov/Un	1	4	Y	1 AI
Eaton-Cutler Hammer	200	UAT-y5213x-FLCH	(where y=E or H, where x=C or U)	1	Ov/Un	1	5	Y	3,3a AI
Eaton-Cutler Hammer	200	UAT-y7213x-FLCH	(where y=E or H, where x=C or U)	3	Ov/Un	1	7	Y	4 AI
Eaton-Cutler Hammer	200	UT-4R2352U-FLCH		1	Ov/Un	4	4/5	N	1,2
Eaton-Cutler Hammer	200	UT-Hy203x-FLCH	(where y=E or H, where x=B or T)	3	Over	1	7	Y	4
Eaton-Cutler Hammer	200	UT-RS202B-FLCH		1	Over	1	4/5	N	1,2
Eaton-Cutler Hammer	200	UT-RS212C-FLCH		1	Ov/Un	1	4/5	N	1,2
Eaton-Cutler Hammer	200	UT-RS213A-FLCH		1	Under	1	4/5	N	1,2
Eaton-Cutler Hammer	200	UT-RS213C-FLCH		1	Ov/Un	1	4/5	N	1,2
Eaton-Cutler Hammer	200	UT-RS223A-FLCH		1	Under	1	4/5	N	1,2
Eaton-Cutler Hammer	200	UT-xR2332U-FLCH	(where x=2-3)	1	Ov/Un	2-3	4/5	N	1,2
Eaton-Cutler Hammer	200	UT-xR2392UU-FLCH	(where x=5-6)	1	Ov/Un	5-6	4/5	N	1,2
Eaton-Cutler Hammer	200	UT-y4203x-FLCH	(where y=E or H, where x=B or T)	1	Over	1	4	Y	1
Eaton-Cutler Hammer	200	UT-y4213x-FLCH	(where y=E or H, where x=C or U)	1	Ov/Un	1	4	Y	1
Eaton-Cutler Hammer	200	UT-y5203x-FLCH	(where y=E or H, where x=B or T)	1	Over	1	5	Y	3,3a
Eaton-Cutler Hammer	200	UT-y5213x-FLCH	(where y=E or H, where x=C or U)	1	Ov/Un	1	5	Y	3,3a
Eaton-Cutler Hammer	200	UT-y7213x-FLCH	(where y=E or H, where x=C or U)	3	Ov/Un	1	7	Y	4
Eaton-Cutler Hammer	225	35MMx20R12	(where x=1-4)	1	Ov/Un	1-4	5	Y	3,3a
Eaton-Cutler Hammer	225	37MMx20R12	(where x=1-4)	3	Ov/Un	1	7	Y	4
Eaton-Cutler Hammer	400	1008836x	(where x = CH or ECH)	1	Ov/Un	1	4	Y	1
Eaton-Cutler Hammer	400	1008837x	(where x = CH or ECH)	1	Ov/Un	1	4	Y	1 AI
Eaton-Cutler Hammer	400	35MM140R1240		1	Under	1	5	Y	3
Eaton-Cutler Hammer	400	35MM240R1 240		1	Under	1	5	Y	3
Eaton-Cutler Hammer	400	37MM140R1240		3	Under	1	7	Y	4
Eaton-Cutler Hammer	400	37MM240R1 240		3	Under	1	7	Y	4
Eaton-Cutler Hammer	400	CG1212P400BSL		1	Under	1	4	Y	1,2
Eaton-Cutler Hammer	400	CG404242SHL		1	Under	1	4	Y	1,2
Eaton-Cutler Hammer	400	CG40SHL		1	Under	1	4	Y	1,2
Eaton-Cutler Hammer	400	HP404040SHL		1	Under	1	4	Y	1,2
Eaton-Cutler Hammer	400	HP40SHL		1	Under	1	4	Y	1,2
Eaton-Cutler Hammer	400	HP816P400BSL		1	Under	1	4	Y	1,2



Approved Metering Equipment Enclosure List

Revised
7/1/2011

Manufacturer	Amps	Catalog Number		Phase	Service	Pos	Term	Bypass	Config
Eaton-Cutler Hammer	400	UAT-y4300T-FLCH	(where y=E or H)	1	Over	1	4	Y	1 AI
Eaton-Cutler Hammer	400	UAT-y5300T-FLCH	(where y=E or H)	1	Over	1	5	Y	3,3a AI
Eaton-Cutler Hammer	400	UAT-y5330U-FLCH	(where y=E or H)	1	Ov/Un	1	5	Y	3,3a AI
Eaton-Cutler Hammer	400	UAT-y7300T-FLCH	(where y=E or H)	3	Over	1	7	Y	4 AI
Eaton-Cutler Hammer	400	UAT-y7330U-FLCH	(where y=E or H)	3	Ov/Un	1	7	Y	4 AI
Eaton-Cutler Hammer	400	UT-y4300T-FLCH	(where y=E or H)	1	Over	1	4	Y	1
Eaton-Cutler Hammer	400	UT-y5300T-FLCH	(where y=E or H)	1	Over	1	5	Y	3,3a
Eaton-Cutler Hammer	400	UT-y5330U-FLCH	(where y=E or H)	1	Ov/Un	1	5	Y	3,3a
Eaton-Cutler Hammer	400	UT-y7300T-FLCH	(where y=E or H)	3	Over	1	7	Y	4
Eaton-Cutler Hammer	400	UT-y7330U-FLCH	(where y=E or H)	3	Ov/Un	1	7	Y	4
Eaton-Cutler Hammer	600	CH9507K4 (Requires Ridget Lugs)	TECO ONLY	1	Ov/Un	1	4	Y	5a
Eaton-Cutler Hammer	600	CH9526K7 (Requires Ridged Lugs)	FPL & TECO ONLY	3	Ov/Un	1	7	Y	5
Eaton-Cutler Hammer	600	CH9527K7 (Requires Ridged Lugs)	FPL & TECO ONLY	3	Ov/Un	1	7	Y	5 AI
Elec.Prod.	100	RVPD-xxxx-FPL		1	Under	2	4	N	1
Elec.Prod.	100	RVP-xxxx-FPL		1	Under	1	4	N	1
Elec.Prod.	200	MHPD-xxxx-FPL		1	Under	2	4	N	1
Elec.Prod.	200	MHP-xxxx-FPL		1	Under	1	4	N	1
Emerson	125	MESBGFXLW11FBZ1		1	Under	1	5	Y	3a
Emerson	125	MESBGFXLW11FBZ1P		1	Under	1	5	Y	3a
Emerson	125	MESBGFXLW11KBZ1		1	Under	1	5	Y	3a
Emerson	125	MESBGFXLW11KBZ1P		1	Under	1	5	Y	3a
Emerson	200	MESBAATLW11FBZ1		1	Under	1	5	Y	3a
Emerson	200	MESBAATLW11FBZ1P		1	Under	1	5	Y	3a
Emerson	200	MESBAATLW11KBZ1		1	Under	1	5	Y	3a
Emerson	200	MESBAATLW11KBZ1P		1	Under	1	5	Y	3a
General Electric	125	TMMR2212R		1	Under	2	4/5	N	1,2
General Electric	125	TMMR4x12R	(where x=3-4)	1	Under	3-4	4/5	N	1,2
General Electric	125	TMMR6x12R	(where x=5-6)	1	Under	5-6	4/5	N	1,2
General Electric	125	TMPR8x12R	(where x=2-6)	1	Under	2-6	4/5	N	1,2
General Electric	150	TSMF415CSFL		1	Ov/Un	1	4/5	N	1,2
General Electric	150	TSMF815CSFL		1	Ov/Un	1	4/5	N	1,2
General Electric	200	TMMR4x20R	(where x=2-6)	1	Ov/Un	2-6	4	N	1,2
General Electric	200	TMMR6x20R	(where x=3-6)	1	Under	3-6	4/5	N	1,2
General Electric	200	TMPR312x22R	(where x=1-4)	3	Ov/Un	1-4	7	Y	4
General Electric	200	TMPR8x20R	(where x=2-4)	1	Under	2-4	4/5	N	1,2
General Electric	200	TSMF420CSFL		1	Ov/Un	1	4/5	N	1,2
General Electric	200	TSMF820CSFL		1	Ov/Un	1	4/5	N	1,2
General Electric	225	TMPR12x22R	(where x=1-4)	1	Ov/Un	1-4	5	Y	3,3a
General Electric	400	TMPR1240RB		1	Ov/Un	1	5	Y	3,3a



Approved Metering Equipment Enclosure List

Revised
7/1/2011

Manufacturer	Amps	Catalog Number	Phase	Service	Pos	Term	Bypass	Config	
General Electric	400	TMPR31240RB	3	Ov/Un	1	7	Y	4	
General Electric	400	TSDR840UFCU	1	Under	1	4/5	Y	1,2	
Landis & Gyr	100	UAT111-XGF	1	Over	1	4/5	N	1	
Landis & Gyr	100	UAT131-XGF	1	Over	1	4/5	N	1 AI	
Landis & Gyr	200	40005-01F	1	Over	1	5	Y	3,3a	
Landis & Gyr	200	40007-01F	3	Over	1	7	Y	4	
Landis & Gyr	200	40405-025F	1	Ov/Un	1	5	Y	3,3a	
Landis & Gyr	200	40407-025F	3	Ov/Un	1	7	Y	4	
Landis & Gyr	200	41005-01F	1	Over	1	5	Y	3,3a	
Landis & Gyr	200	41007-01F	3	Over	1	7	Y	4 AI	
Landis & Gyr	200	41405-025F	1	Ov/Un	1	5	Y	3,3a AI	
Landis & Gyr	200	41407-025F	3	Ov/Un	1	7	Y	4 AI	
Landis & Gyr	200	LG0408B1200RT	1	Ov/Un	1	4	N	1	
Landis & Gyr	200	LG0606L1200R or RA	1	Ov/Un	1	4/5	N	1, 1 AI	
Landis & Gyr	200	UA27x6-ZGF	(where x=1 or 3)	1	Ov/Un	2	1	N	1, 1 AI
Landis & Gyr	200	UA37x7-ZGF	(where x=1 or 3)	1	Ov/Un	3	1	N	1, 1 AI
Landis & Gyr	200	UA47x9-ZGF	(where x=1 or 3)	1	Ov/Un	4	1	N	1, 1 AI
Landis & Gyr	200	UA57x9-MGF	(where x=1 or 3)	1	Ov/Un	5	1	N	1, 1 AI
Landis & Gyr	200	UA67x9-MGF	(where x=1 or 3)	1	Ov/Un	6	1	N	1, 1 AI
Landis & Gyr	200	UAT3 17-0GF	1	Over	1	4/5	N	1	
Landis & Gyr	200	UAT337-0GF	1	Over	1	4/5	N	1 AI	
Landis & Gyr	200	UAT417-PGF	1	Under	1	4/5	N	1,2	
Landis & Gyr	200	UAT417-XGF	1	Ov/Un	1	4/5	N	1,2	
Landis & Gyr	200	UAT437-PGF	1	Under	1	4/5	N	1 AI	
Landis & Gyr	200	UAT437-XGF	1	Ov/Un	1	4/5	N	1 AI	
Landis & Gyr	400	41105-02FL	1	Ov/Un	1	5	Y	3,3a AI	
Landis & Gyr	400	44707-02FL	3	Ov/Un	1	7	Y	4	
Landis & Gyr	400	47705-02FL	1	Ov/Un	1	5	Y	3,3a	
Landis & Gyr	400	49005-02FL	1	Ov/Un	1	5	Y	3,3a	
Landis & Gyr	400	49007-02FL	3	Ov/Un	1	7	Y	4	
Landis & Gyr	400	49105-02FL	1	Ov/Un	1	5	Y	3,3a AI	
Landis & Gyr	400	49107-02FL	3	Ov/Un	1	7	Y	4 AI	
Landis & Gyr	600	98 10-9507 (Requires Ridged Lugs) TECO ONLY	1	Ov/Un	1	4	Y	5a	
Landis & Gyr	600	98 17-9526 (Requires Ridged Lugs) FPL & TECO ONLY	3	Ov/Un	1	7	Y	5	
Landis & Gyr	600	98 17-9527 (Requires Ridged Lugs) FPL & TECO ONLY	3	Ov/Un	1	7	Y	5 AI	
Midwest	100	M0xxC010-FMG (where xx=32,36,38,41,51,55,76)	1	Ov-ped	1	4/5	N	1,2	
Midwest	100	M0xxC010U-FMG (where xx=32,36,38,41,51,55,76)	1	Un-ped	1	4/5	N	1,2	
Midwest	100	M0xxC033-FMG (where xx=32,36,38,41,51,55,76)	1	Ov-ped	1	4/5	N	1,2	
Midwest	100	M0xxC033U-FMG (where xx=32,36,38,41,51,55,76)	1	Un-ped	1	4/5	N	1,2	



Approved Metering Equipment Enclosure List

Revised
7/1/2011

Manufacture	Amps	Catalog Number	Phase	Service	Pos	Term	Bypass	Config
Midwest	100	UTZ-6R1 13 1C-FLMEP	1	Ov/Un	6	4/5	N	1,2
Midwest	100	UTZ-xR1 121C-FLMEP (where x=2-5)	1	Ov/Un	2-5	4/5	N	1,2
Midwest	125	UATZ-RS101C-FLMEP	1	Ov/Un	1	4/5	N	1,2 AI
Midwest	125	UTZ-RS101C-FLMEP	1	Ov/Un	1	4/5	N	1,2
Midwest	200	MPx00S0FMG (where x=1-4)	1	Under	1-4	4/5	N	1,2 AI
Midwest	200	MPx00S1FMG (where x=1-4)	1	Under	1-4	4/5	N	1,2 AI
Midwest	200	MPx20B0FMG (where x=1-4)	1	Under	1-4	4/5	N	1,2 AI
Midwest	200	MPx20B1FMG (where x=1-4)	1	Under	1-4	4/5	N	1,2 AI
Midwest	200	PM5x220B0FMG (where x=1-4)	1	Under	1-4	4/5	N	1,2 AI
Midwest	200	UAT-H4203x-FLMEP (where x=B or T)	1	Over	1	4	Y	1 AI
Midwest	200	UAT-H4213x-FLMEP (where x=C or U)	1	Ov/Un	1	4	Y	1 AI
Midwest	200	UAT-H5203x-FLMEP (where x=B or T)	1	Over	1	5	Y	3,3a AI
Midwest	200	UAT-H5213x-FLMEP (where x=C or U)	1	Ov/Un	1	5	Y	3,3a AI
Midwest	200	UAT-H7203x-FLMEP (where x=B or T)	3	Over	1	7	Y	4 AI
Midwest	200	UAT-H7213x-FLMEP (where x=C or U)	3	Ov/Un	1	7	Y	4 AI
Midwest	200	UAT-RS202B-FLMEP	1	Over	1	4/5	N	1,2 AI
Midwest	200	UAT-RS212C-FLMEP	1	Ov/Un	1	4/5	N	1,2 AI
Midwest	200	UAT-RS213A-FLMEP	1	Under	1	4/5	N	1,2 AI
Midwest	200	UAT-RS213C-FLMEP	1	Ov/Un	1	4/5	N	1,2 AI
Midwest	200	UAT-RS223A-FLMEP	1	Under	1	4/5	N	1,2 AI
Midwest	200	UT-4R2352U-FLMEP	1	Ov/Un	4	4/5	N	1,2
Midwest	200	UT-H4203x-FLMEP (where x=B or T)	1	Over	1	4	Y	1
Midwest	200	UT-H4213x-FLMEP (where x=C or U)	1	Ov/Un	1	4	Y	1
Midwest	200	UT-H5203x-FLMEP (where x=B or T)	1	Over	1	5	Y	3,3a
Midwest	200	UT-H5213x-FLMEP (where x=C or U)	1	Ov/Un	1	5	Y	3,3a
Midwest	200	UT-H7203x-FLMEP (where x=B or T)	3	Over	1	7	Y	4
Midwest	200	UT-H7213x-FLMEP (where x=C or U)	3	Ov/Un	1	7	Y	4
Midwest	200	UT-RS202B-FLMEP	1	Over	1	4/5	N	1,2
Midwest	200	UT-RS212C-FLMEP	1	Ov/Un	1	4/5	N	1,2
Midwest	200	UT-RS213A-FLMEP	1	Under	1	4/5	N	1,2
Midwest	200	UT-RS213C-FLMEP	1	Ov/Un	1	4/5	N	1,2
Midwest	200	UT-RS223A-FLMEP	1	Under	1	4/5	N	1,2
Midwest	200	UT-xR2332U-FLMEP (where x=2-3)	1	Ov/Un	2-3	4/5	N	1,2
Midwest	200	UT-xR2392UU-FLMEP (where x=5-6)	1	Ov/Un	5-6	4/5	N	1,2
Midwest	400	1008836MEP	1	Ov/Un	1	4	Y	1
Midwest	400	1008837MEP	1	Ov/Un	1	4	Y	1 AI
Midwest	400	RS455***FMG	1	Under	1	4/5	Y	1,2
Midwest	400	UAT-H4300T-FLMEP	1	Over	1	4	Y	1 AI
Midwest	400	UAT-H5300T-FLMEP	1	Over	1	5	Y	3,3a AI



Approved Metering Equipment Enclosure List

Revised
7/1/2011

Manufacture	Amps	Catalog Number	Phase	Service	Pos	Term	Bypass	Config
Midwest	400	UAT-H5330U-FLMEP	1	Ov/Un	1	5	Y	3,3a AI
Midwest	400	UAT-H7300T-FLMEP	3	Over	1	7	Y	4 AI
Midwest	400	UAT-H7330U-FLMEP	3	Ov/Un	1	7	Y	4 AI
Midwest	400	UT-H4300T-FLMEP	1	Over	1	4	Y	1
Midwest	400	UT-H5300T-FLMEP	1	Over	1	5	Y	3,3a
Midwest	400	UT-H5330U-FLMEP	1	Ov/Un	1	5	Y	3,3a
Midwest	400	UT-H7300T-FLMEP	3	Over	1	7	Y	4
Midwest	400	UT-H7330U-FLMEP	3	Ov/Un	1	7	Y	4
Milbank	100	U349y-XL-HSP (where y=2-6)	1	Ov/Un	2-6	4/5	N	1,2
Milbank	100	U513y-O-100P-FMG (where y=6-7)	1	Under	1-2	4/5	N	1,2
Milbank	100	U513y-O-100S-FMG (where y=6-7)	1	Under	1-2	4/5	N	1,2
Milbank	100	UAP349y-XL-HSP (where y=2-6)	1	Ov/Un	2-6	4/5	N	1,2 AI
Milbank	125	U285y-X-HSP (where y=2-6)	1	Ov/Un	2-6	4/5	N	1,2
Milbank	125	U3505-XL-HSP	1	Ov/Un	1	5	Y	3,3a
Milbank	125	U3505-XL-TG-HSP	1	Ov/Un	1	5	Y	3,3a
Milbank	125	U3506-XL-TG-HSP	3	Ov/Un	1	7	Y	4
Milbank	125	U513y-O-125P-FMG (where y=6-7)	1	Under	1-2	4/5	N	1,2
Milbank	125	U513y-O-125S-FMG (where y=6-7)	1	Under	1-2	4/5	N	1,2
Milbank	125	U8435-XL-TG-HSP	1	Over	1	4/5	N	1,2
Milbank	125	UAP3505-XL-TG-HSP	1	Ov/Un	1	5	Y	3,3a AI
Milbank	125	UAP3506-XL-TG-HSP	3	Ov/Un	1	7	Y	4 AI
Milbank	125	UAP8435-XL-TG-HSP	1	Ov/Un	1	4/5	N	1,2 AI
Milbank	150	U123y-X-HSP (where y=2-6)	1	Ov/Un	2-6	4/5	N	1,2
Milbank	150	U3312-XL-TG-HSP	1	Ov/Un	1	4/5	N	1,2
Milbank	150	U513y-O-150P-FMG (where y=6-7)	1	Under	1-2	4/5	N	1,2
Milbank	150	U513y-O-150S-FMG (where y=6-7)	1	Under	1-2	4/5	N	1,2
Milbank	150	UAP123y-X-HSP (where y=2-3)	1	Ov/Un	2-3	4/5	N	1,2 AI
Milbank	200	U125Y-X-HSP (where y=2-6)	1	Ov/Un	2-6	4/5	N	1,2
Milbank	200	U1980-O-HSP	1	Under	1	4/5	N	1,2
Milbank	200	U273y-XT-HSP (where y=2-6)	3	Ov/Un	2-6	7	Y	4
Milbank	200	U286y-X-HSP (where y=2-6)	1	Ov/Un	2-6	4/5	N	1,2
Milbank	200	U287y-XT-HSP (where y=2-6)	1	Ov/Un	2-6	5	Y	3,3a
Milbank	200	U3296-X-HSP	1	Ov/Un	1	5	Y	3,3a
Milbank	200	U3306-X-HSP	3	Ov/Un	1	7	Y	4
Milbank	200	U3850-XL-TG-HSP-PL	1	Ov/Un	1	4/5	N	1,2
Milbank	200	U5136-O-yyy-FMG (where yyy=41,55,75,332,552)	1	Under	1	4/5	N	1,2
Milbank	200	U5137-O-yyy-FMG (where yyy=41,55,75,332,552)	1	Under	2	4/5	N	1,2
Milbank	200	U513y-O-200P-FMG (where y=6-7)	1	Under	1-2	4/5	N	1,2
Milbank	200	U513y-O-200S-FMG (where y=6-7)	1	Under	1-2	4/5	N	1,2



Participants: FPL, GULF, PEF, TECO

Approved Metering Equipment Enclosure List

Revised
7/1/2011

Manufacturer	Amps	Catalog Number		Phase	Service	Pos	Term	Bypass	Config
Milbank	200	U513y-O-FMG	(where y=6-7)	1	Under	1-2	4/5	N	1,2
Milbank	200	U7021-RL-TG-HSP		1	Over	1	4/5	N	1,2
Milbank	200	U7040-O-TG-HSP		1	Under	1	4	N	1,2
Milbank	200	U7040-XL-TG-HSP		1	Ov/Un	1	4/5	N	1,2
Milbank	200	U7043-XL-TG		1	Ov/Un	1	4/5	N	1,2
Milbank	200	U9550-RRL-QG-HSP		1	Over	1	5	Y	3,3a
Milbank	200	U9551-X-QG-HSP		1	Ov/Un	1	5	Y	3,3a
Milbank	200	U9700-RRL-QG-HSP		3	Over	1	7	Y	4
Milbank	200	U9701-X-QG-HSP		3	Ov/Un	1	7	Y	4
Milbank	200	U9801-X-QG -HSP		1	Ov/Un	1	4	Y	1,2
Milbank	200	UAP125y-X-HSP	(where y=2-6)	1	Ov/Un	2-6	4/5	Y	1,2 AI
Milbank	200	UAP1980-O-HSP		1	Under	1	4/5	N	1,2 AI
Milbank	200	UAP3296-X-HSP		1	Ov/Un	1	5	Y	3,3a AI
Milbank	200	UAP3306-X-HSP		3	Ov/Un	1	7	Y	4 AI
Milbank	200	UAP5024-XL		1	Ov/Un	1	4	N	1
Milbank	200	UAP5024-XL-FMG		1	Ov/Un	1	4	N	1
Milbank	200	UAP7021-RL-TG-HSP		1	Over	1	4/5	N	1,2 AI
Milbank	200	UAP7040-O-TG-HSP		1	Under	1	4/5	N	1,2 AI
Milbank	200	UAP7040-XL-TG-HSP		1	Ov/Un	1	4/5	N	1,2 AI
Milbank	200	UAP9550-RRL-QG-HSP		1	Over	1	5	Y	3,3a AI
Milbank	200	UAP9551-X-QG-HSP		1	Ov/Un	1	5	Y	3,3a AI
Milbank	200	UAP9700-RRL-QG-HSP		3	Over	1	7	Y	4 AI
Milbank	200	UAP9701-X-QG-HSP		3	Ov/Un	1	7	Y	4 AI
Milbank	400	U2120-O-HSP		3	Under	1	7	Y	4
Milbank	400	U2124-O-HSP		1	Under	1	4/5	Y	4
Milbank	400	U3313-X-HSP		1	Ov/Un	1	5	Y	3,3a
Milbank	400	U3566-X-HSP		3	Ov/Un	1	7	Y	4
Milbank	400	U3949-X-HSP		1	Over	1	5	Y	3,3a
Milbank	400	UAP2124-O-HSP		1	Under	1	4/5	Y	4 AI
Milbank	400	UAP3313-X-HSP		1	Ov/Un	1	5	Y	3,3a AI
Milbank	400	UAP3566-X-HSP		3	Ov/Un	1	7	Y	4 AI
Milbank	400	UAP3949-X-HSP		1	Over	1	5	Y	3,3a AI
Milbank	400	UAP5864-X-HSP		1	Ov/Un	1	5	Y	3, 3a AI
Milbank	600	U4664-XT-9507 (Ridged Lugs)	TECO ONLY	1	Ov/Un	1	4/5	Y	5a
Milbank	600	U4667-X-8528 (Req. Ridged Lugs)	FPL & TECO ONLY	3	Ov/Un	1	7	Y	5
Milbank	600	U4667-XT-9526(Requires Ridged Lugs)	FPL & TECO ONLY	3	Ov/Un	1	7	Y	5
Milbank	600	UA4667-X-8529 (Req. Ridged Lugs)	FPL & TECO ONLY	3	Ov/Un	1	7	Y	5 AI
Milbank	600	UA4667-XT-9527(Requires Ridged Lugs)	FPL & TECO ONLY	3	Ov/Un	1	7	Y	5 AI
Murray	100	RJ103AXF		1	Over	1	4	N	1



Approved Metering Equipment Enclosure List

Revised
7/1/2011

Manufacturer	Amps	Catalog Number	Phase	Service	Pos	Term	Bypass	Config
Murray	125	JA1224B1125	1	Ov/Un	1	4/5	N	1,2
Murray	150	JA0408B1150T or RT	1	Ov/Un	1	4	N	1
Murray	150	JA0816B1150CT or RCT	1	Ov/Un	1	4	N	1
Murray	150	JA0816B1150TH	1	Ov/Un	1	4/5	N	1,2
Murray	150	JA2040B1150	1	Ov/Un	1	4/5	N	1,2
Murray	150	JA2040B1150RC	1	Ov/Un	1	4	N	1
Murray	150	JA204LS	1	Ov/Un	1	4/5	N	1,2
Murray	150	JC0202B1150	1	Ov/Un	1	4/5	N	1,2
Murray	200	JA0408B1200T or RT	1	Ov/Un	1	4	N	1
Murray	200	JA0606L1200R or RA	1	Ov/Un	1	4/5	N	1, 1 AI
Murray	200	JA0816B1200CT or RCT	1	Ov/Un	1	4	N	1
Murray	200	JA0816B1200TH	1	Ov/Un	1	4/5	N	1,2
Murray	200	JA2040B1200	1	Ov/Un	1	4/5	N	1,2
Murray	200	JA2040B1200RC	1	Ov/Un	1	4	N	1
Murray	200	JA204TS	1	Ov/Un	1	4/5	N	1,2
Murray	200	JC0202B1200	1	Ov/Un	1	4/5	N	1,2
Murray	200	JC0406L1200H	1	Ov/Un	1	4/5	N	1,2
Murray	200	RB103AR	1	Ov/Un	1	4/5	N	1,2
Murray	200	RH173CRF	1	Ov/Un	1	5	Y	3,3a
Murray	200	RH173GRF	3	Ov/Un	1	7	Y	4
Murray	200	RS103AVF	1	Under	1	4/5	N	1,2
Murray	200	RS103AXF	1	Over	1	4	N	1
Murray	400	JA0816B1350RLTM	1	Ov/Un	1	4/5	Y	1,2
Murray	400	JA0816B1400RLTM	1	Ov/Un	1	4/5	Y	1,2
Murray	400	JC0404L1400RLM	1	Ov/Un	1	4/5	Y	1,2
Murray	400	JC0408B1400RLTM	1	Ov/Un	1	4/5	Y	1,2
Siemens	100	WMLx3100RJ (where x=1-4)	3	Under	1-4	7	Y	4
Siemens	125	MC1224B1125	1	Ov/Un	1	4/5	N	1,2
Siemens	125	SPxx11RJ (where xx=22, 33, 44, 45, 46, 65, 66)	1	Ov/Un	2-6	4/5	N	1,2
Siemens	125	SUAT111-0GF	1	Over	1	4	N	1
Siemens	125	W3MMx (where x=1-4)	3	Under	1-4	7	Y	4
Siemens	125	WMMx1 125R (where x=2-6)	1	Under	2-6	4	N	1,2
Siemens	125	WMMx2125RJ (where x=2-6)	3	Under	2-6	5	N	2
Siemens	150	MC0408B1150T or RT	1	Ov/Un	1	4	N	1
Siemens	150	MC0408MB1150T	1	Ov/Un	1	4/5	N	1,2
Siemens	150	MC0816B1150CT or RCT	1	Ov/Un	1	4	N	1
Siemens	150	MC0816B1150TH	1	Ov/Un	1	4/5	N	1,2
Siemens	150	MC2040B1150	1	Ov/Un	1	4/5	N	1,2
Siemens	150	MC2040B1150RC	1	Ov/Un	1	4	N	1



Approved Metering Equipment Enclosure List

Revised
7/1/2011

Manufacturer	Amps	Catalog Number	Phase	Service	Pos	Term	Bypass	Config	
Siemens	150	MM0202B1150	1	Ov/Un	1	4/5	N	1,2 St	
Siemens	200	MC0408B1200T or RT	1	Ov/Un	1	4	N	1	
Siemens	200	MC0408MB1200T	1	Ov/Un	1	4/5	N	1,2	
Siemens	200	MC0606L1200R or RA	1	Ov/Un	1	4/5	N	1,1 Al	
Siemens	200	MC0816B1200CT or RCT	1	Ov/Un	1	4	N	1	
Siemens	200	MC0816B1200TH	1	Ov/Un	1	4/5	N	1,2	
Siemens	200	MC2040B1200	1	Ov/Un	1	4/5	N	1,2	
Siemens	200	MC2040B1200RC	1	Ov/Un	1	4	N	1	
Siemens	200	MM0202B1200	1	Ov/Un	1	4/5	N	1,2 St	
Siemens	200	MM0406L1200H	1	Ov/Un	1	4/5	N	1,2	
Siemens	200	S40405-015F	1	Ov/Un	1	5	Y	3,3a	
Siemens	200	S40407-015F	3	Ov/Un	1	7	Y	4	
Siemens	200	SPxx12RJ	(where xx=42, 43, 44, 65, 66)	1	Ov/Un	2-6	4/5	N	1,2
Siemens	200	SUAT3 17-OGF	1	Over	1	4	N	1	
Siemens	200	SUAT417-PGF	1	Under	1	4/5	N	1,2	
Siemens	200	SUAT417-XGF	1	Ov/Un	1	4/5	N	1,2	
Siemens	200	WMMx1225R	(where x=2-6)	1	Under	2-6	4	N	3
Siemens	200	WMMx1225R	(where x=2-6)	1	Under	2-6	4	N	3
Siemens	200	WMMx2225RJ	(where x=2-6)	3	Under	2-6	5	N	3a
Siemens	200	WMMx1225R	(where x=2-6)	1	Under	2-6	4	N	3
Siemens	200	WMMx2225RJ	(where x=2-6)	3	Under	2-6	5	N	3a
Siemens	225	WML1x225RJ	(where x=1-4)	1	Ov/Un	1-4	4	Y	3,3a
Siemens	225	WMLx1225RJ	(where x=2-6)	1	Ov/Un	2-6	4	Y	3,3a
Siemens	225	WMLx2yz225RJ	(where x=2 or 4, yz=AB, BC or CA)	1	Ov/Un	2or4	5	Y	3,3a
Siemens	400	MC0408B1400RLTM	1	Ov/Un	1	4/5	Y	1,2	
Siemens	400	MC0816B1350RLTM	1	Ov/Un	1	4/5	Y	1,2	
Siemens	400	MC0816B1400RLTM	1	Ov/Un	1	4/5	Y	1,2	
Siemens	400	MM0404L1400RLM	1	Ov/Un	1	4/5	Y	1,2	
Siemens	400	W1MM1400	1	Under	1	4	Y	1	
Siemens	400	WMKxy400z	where (x=1 or 2)(y=1 -3)(z=R or RJ)	1	Under	1	4	Y	1
Siemens	400	WMLxy400RJ	where (x=1 or 2) (y=1-3)	1	Under	1	4	Y	1
Siemens	400	S9817-8061	Bolt-in	3	Under	3	7	Y	4
Siemens	400	S9817-8062	Bolt-in	3	Under	3	7	Y	4
Siemens	600	WMKxy600z	where (x=1 or 2)(y=1-3)(z=R or RJ)	1	Under	1	4	N	1
Square D	100	UTZ-6R1 13 1C-FLSQD	1	Ov/Un	6	4/5	N	1,2	
Square D	100	UTZ-xR1 121C-FLSQD	(where x=2-5)	1	Ov/Un	2-5	4/5	N	1,2
Square D	125	EZMR11y125	(where y=3-6)	1	Mtr Ctr	3-6	5	N	1,2
Square D	125	EZMR11y125CU	(where y=3-6)	1	Mtr Ctr	3-6	5	N	1,2
Square D	125	EZMR11y125X	(where y=3-6)	1	Mtr Ctr	3-6	5	N	1,2



Approved Metering Equipment Enclosure List

Revised
7/1/2011

Manufacturer	Amps	Catalog Number	Phase	Service	Pos	Term	Bypass	Config
Square D	125	EZMR31y125	1	Mtr Ctr	3-5	5	N	1,2
Square D	125	EZMR31y125CU (where y=3-5)	1	Mtr Ctr	3-5	5	N	1,2
Square D	125	EZMR31y125X (where y=3-5)	1	Mtr Ctr	3	5	N	1,2
Square D	125	MPRyy125 (where yy=22,33,44,55,66)	1	Ov/Un	2-6	5	N	1,2
Square D	125	UATZ-RS101C-FLSQD	1	Ov/Un	1	4/5	N	1,2 AI
Square D	125	UTZ-RS101C-FLSQD	1	Ov/Un	1	4/5	N	1,2
Square D	150	QC816F150C	1	Ov/Un	1	4/5	N	1,2
Square D	150	RC816F150C	1	Ov/Un	1	4/5	N	1,2
Square D	200	EZML1 1y200 z (where y=1-4)	1	Mtr Ctr	1-4	5	Y	1,2
Square D	200	EZML31y200 (where y=2-4)	1	Mtr Ctr	2-4	5	Y	3a
Square D	200	EZML33y200 (where y=1-4)	3	Mtr Ctr	1	7	Y	4
Square D	200	EZMR11y200 (where y=2-4)	1	Mtr Ctr	2-4	5	N	1,2
Square D	200	EZMR1 1y200CU (where y=2-4)	1	Mtr Ctr	2	5	N	1,2
Square D	200	EZMR1 1y200X (where y=2-4)	1	Mtr Ctr	2	5	N	1,2
Square D	200	MPLyy200 (where yy=32, 43,64)	1	Ov/Un	2-4	5	Y	3
Square D	200	MPR4y200 (where y=2-3)	1	Ov/Un	2-3	5	N	1,2
Square D	200	MPR64200 (where y=5-6)	1	Ov/Un	4	5	N	1,2
Square D	200	MPR8y200	1	Ov/Un	5-6	5	N	1,2
Square D	200	QC12L200C	1	Ov/Un	1	4/5	N	1,2
Square D	200	QC2442M200C	1	Ov/Un	1	4/5	Y/N	1,2
Square D	200	QC816F200C	1	Ov/Un	1	4/5	N	1,2
Square D	200	RC12L200C	1	Ov/Un	1	4/5	N	1,2
Square D	200	RC2040M200C	1	Ov/Un	1	4/5	N	1,2
Square D	200	RC816F200C	1	Ov/Un	1	4/5	N	1,2
Square D	200	UAT-H4203x-FLSQD (where x=B or T)	1	Over	1	4	Y	1 AI
Square D	200	UAT-H4213x-FLSQD (where x= C or U)	1	Ov/Un	1	4	Y	1 AI
Square D	200	UAT-H5203x-FLSQD (where x= B or T)	1	Over	1	5	Y	3,3a AI
Square D	200	UAT-H5213x-FLSQD (where x= C or U)	1	Ov/Un	1	5	Y	3,3a AI
Square D	200	UAT-H7203x-FLSQD (where x=B or T)	3	Over	1	7	Y	4 AI
Square D	200	UAT-H7213x-FLSQD (where x=C or U)	3	Ov/Un	1	7	Y	4 AI
Square D	200	UAT-RS202B-FLSQD	1	Over	1	4/5	N	1,2 AI
Square D	200	UAT-RS212C-FLSQD	1	Ov/Un	1	4/5	N	1,2 AI
Square D	200	UAT-RS213A-FLSQD	1	Under	1	4/5	N	1,2 AI
Square D	200	UAT-RS213C-FLSQD	1	Ov/Un	1	4/5	N	1,2 AI
Square D	125	UTZ-RS101C-FLSQD	1	Ov/Un	1	4/5	N	1,2
Square D	150	QC816F150C	1	Ov/Un	1	4/5	N	1,2
Square D	150	RC816F150C	1	Ov/Un	1	4/5	N	1,2
Square D	200	EZML1 1y200 (where y=1-4)	1	Mtr Ctr	1-4	5	Y	1,2
Square D	200	EZML31y200 (where y=2-4)	1	Mtr Ctr	2-4	5	Y	3a



Approved Metering Equipment Enclosure List

Revised
7/1/2011

Manufacture	Amps	Catalog Number		Phase	Service	Pos	Term	Bypass	Config
Square D	200	EZML33y200	(where y=1-4)	3	Mtr Ctr	1	7	Y	4
Square D	200	EZMR11y200	(where y=2-4)	1	Mtr Ctr	2-4	5	N	1,2
Square D	200	EZMR1 1y200CU	(where y=2-4)	1	Mtr Ctr	2	5	N	1,2
Square D	200	EZMR1 1y200X	(where y=2-4)	1	Mtr Ctr	2	5	N	1,2
Square D	200	MPLyy200	(where yy=32,43,64)	1	Ov/Un	2-4	5	Y	3
Square D	200	MPR4y200	(where y=2-3)	1	Ov/Un	2-3	5	N	1,2
Square D	200	MPR64200		1	Ov/Un	4	5	N	1,2
Square D	200	MPR8y200	(where y=5-6)	1	Ov/Un	5-6	5	N	1,2
Square D	200	QC12L200C		1	Ov/Un	1	4/5	N	1,2
Square D	200	QC2442M200C		1	Ov/Un	1	4/5	Y/N	1,2
Square D	200	QC816F200C		1	Ov/Un	1	4/5	N	1,2
Square D	200	RC12L200C		1	Ov/Un	1	4/5	N	1,2
Square D	200	RC2040M200C		1	Ov/Un	1	4/5	N	1,2
Square D	200	RC816F200C		1	Ov/Un	1	4/5	N	1,2
Square D	200	UAT-H4203x-FLSQD	(where x=B or T)	1	Over	1	4	Y	1 AI
Square D	200	UAT-H4213x-FLSQD	(where x=C or U)	1	Ov/Un	1	4	Y	1 AI
Square D	200	UAT-H5203x-FLSQD	(where x=B or T)	1	Over	1	5	Y	3,3a AI
Square D	200	UAT-H5213x-FLSQD	(where x=C or U)	1	Ov/Un	1	5	Y	3,3a AI
Square D	200	UAT-H7203x-FLSQD	(where x=B or T)	3	Over	1	7	Y	4 AI
Square D	200	UAT-H7213x-FLSQD	(where x=C or U)	3	Ov/Un	1	7	Y	4 AI
Square D	200	UAT-RS202B-FLSQD		1	Over	1	4/5	N	1,2 AI
Square D	200	UAT-RS212C-FLSQD		1	Ov/Un	1	4/5	N	1,2 AI
Square D	200	UAT-RS213A-FLSQD		1	Under	1	4/5	N	1,2 AI
Square D	200	UAT-RS213C-FLSQD		1	Ov/Un	1	4/5	N	1,2 AI
Square D	200	UAT-RS223A-FLSQD		1	Under	1	4/5	N	1,2 AI
Square D	200	UT-4R2352U-FLSQD		1	Ov/Un	4	4/5	N	1,2
Square D	200	UT-H4203x-FLSQD	(where x=B or T)	1	Over	1	4	Y	1
Square D	200	UT-H4213x-FLSQD	(where x=C or U)	1	Ov/Un	1	4	Y	1
Square D	200	UT-H5203x-FLSQD	(where x=B or T)	1	Over	1	5	Y	3,3a
Square D	200	UT-H5213x-FLSQD	(where x=C or U)	1	Ov/Un	1	5	Y	3,3a
Square D	200	UT-H7203x-FLSQD	(where x=B or T)	3	Over	1	7	Y	4
Square D	200	UT-H7213x-FLSQD	(where x=C or U)	3	Ov/Un	1	7	Y	4
Square D	200	UT-RS202B-FLSQD		1	Over	1	4/5	N	1,2
Square D	200	UT-RS212C-FLSQD		1	Ov/Un	1	4/5	N	1,2
Square D	200	UT-RS213A-FLSQD		1	Under	1	4/5	N	1,2
Square D	200	UT-RS213C-FLSQD		1	Ov/Un	1	4/5	N	1,2
Square D	200	UT-RS223A-FLSQD		1	Under	1	4/5	N	1,2
Square D	200	UT-xR2332U-FLSQD	(where x=2-3)	1	Ov/Un	2-3	4/5	N	1,2
Square D	200	UT-xR2392UU-FLSQD	(where x=5-6)	1	Ov/Un	5-6	4/5	N	1,2



Approved Metering Equipment Enclosure List

Revised
7/1/2011

Manufacture	Amps	Catalog Number		Phase	Service	Pos	Term	Bypass	Config
Square D	225	EZML11x225	(where x=1-4)	1	Mtr Ctr	1-4	5	Y	1,2
Square D	225	EZML31x225	(where x=2-4)	1	Mtr Ctr	2-4	5	Y	3a
Square D	225	EZML33x225	(where x=1-4)	3	Mtr Ctr	1	7	Y	4
Square D	225	EZMR1 1x200X	(where x=2-4)	1	Mtr Ctr	2	5	N	1,2
Square D	225	EZMR11x225	(where x=2-5)	1	Mtr Ctr	2-5	5	N	1,2
Square D	225	EZMR11x225CU	(where x=2-5)	1	Mtr Ctr	2-5	5	N	1,2
Square D	225	EZMR31x225	(where x=2-5)	1	Mtr Ctr	2-5	5	N	1,2
Square D	300	SU3040D300L	(with Red Dot retrofit label)	1	Under	1	4/5	Y	3
Square D	400	1008836SQD		1	Ov/Un	1	4	Y	1
Square D	400	1008837SQD		1	Ov/Un	1	4	Y	1 AI
Square D	400	CU12L400L	(with Red Dot retrofit label)	1	Under	1	4/5	Y	3
Square D	400	EZML31y400	(where y=1-2)	1	Mtr Ctr	1-2	5	Y	3a
Square D	400	EZML33y400	(where y=1-2)	3	Mtr Ctr	1-2	7	Y	4
Square D	400	QU12L400xL	(where x = C or S)	1	Under	1	4/5	Y	3
Square D	400	QU816D400SL		1	Under	1	4/5	Y	3
Square D	400	SU3040D400L	(with Red Dot retrofit label)	1	Under	1	4/5	Y	3
Square D	400	UAT-H4300T-FLSQD		1	Over	1	4	Y	1 AI
Square D	400	UAT-H5300T-FLSQD		1	Over	1	5	Y	3,3a AI
Square D	400	UAT-H5330U-FLSQD		1	Ov/Un	1	5	Y	3,3a AI
Square D	400	UAT-H7300T-FLSQD		3	Over	1	7	Y	4 AI
Square D	400	UAT-H7330U-FLSQD		3	Ov/Un	1	7	Y	4 AI
Square D	400	UT-H4300T-FLSQD		1	Over	1	4	Y	1
Square D	400	UT-H5300T-FLSQD		1	Over	1	5	Y	3,3a
Square D	400	UT-H5330U-FLSQD		1	Ov/Un	1	5	Y	3,3a
Square D	400	UT-H7300T-FLSQD		3	Over	1	7	Y	4
Square D	400	UT-H7330U-FLSQD		3	Ov/Un	1	7	Y	4

PREPARED BY

SUBJECT

Jim DeMars
FPL

FPL APPROVED IT METERING EQUIPMENT ENCLOSURE LIST

VII: 15 of 18

Instrument Transformer (IT) Rated Units - Before Purchase, Please Contact your FPL Representative

NOTE: Instrument Transformer Metering must be approved by FPL.

INSTRUMENT TRANSFORMER RATED METER SOCKETS

MANUFACTURER	CATALOG NUMBER	STYLE & MATERIAL	PHASE	APPROX SIZE (H" X W" X D")	CONFIGURATION
Anchor	RTSS6-73-FP&L	RTSS-6 Steel	1	20 x 12 x 4-1/2	6 - 12
	RTSA6-73-FP&L	RTSA-6 Alum	1	20 x 12 x 4-1/2	6 - 12
	RTSS13-13-FP&L	RTSS-13 Steel	3	20 x 12 x 4-1/2	6 - 12
	RTSA13-13-FP&L	RTSA-13 Alum	3	20 x 12 x 4-1/2	6 - 12
Cooper B-Line	ST02063N1GR1F	Q6 Steel	1	20 x 12 x 4-1/2	6 - 12
	ST02063N1AL1F	Q6 Alum	1	20 x 12 x 4-1/2	6 - 12
	ST02133N1GR1F	TUV Steel	3	20 x 12 x 4-1/2	6 - 12
	ST02133N1AL1F	TUV Alum	3	20 x 12 x 4-1/2	6 - 12
Landis & Gyr	9837-0422	PTS-6 Aluminum	1	20 x 12 x 4-1/2	6 - 12
	9837-0423	PTS-6 Steel	1	20 x 12 x 4-1/2	6 - 12
	9837-0424	PTS-13 Aluminum	3	20 x 12 x 4-1/2	6 - 12
	9837-0425	PTS-13 Steel	3	20 x 12 x 4-1/2	6 - 12
Meter Devices Co.	602U3010C6-388	Q6 Steel	1	20 x 12 x 4-1/2	6 - 12
	652U3010C6-388	Q6 Alum	1	20 x 12 x 4-1/2	6 - 12
	602U3010C13-387	TUV Steel	3	20 x 12 x 4-1/2	6 - 12
	605U8010C13-934	TUV/Steel Snap 2	3	20 x 12 x 4-1/2	6 - 12
	652U3010C13-387	TUV Alum	3	20 x 12 x 4-1/2	6 - 12
	655U8010C13-934	TUV/Alum Snap 2	3	20 x 12 x 4-1/2	6 - 12
Milbank	UC4511	Q6 Steel	1	20 x 12 x 4-1/8	6-12
	UAPC4511	Q6 Alum	1	20 x 12 x 4-1/8	6-12
	UC4512	TUV Steel	3	20 x 12 x 4-1/8	6-12
	UAPC4512	TUV Alum	3	20 x 12 x 4-1/8	6-12

PREPARED BY

SUBJECT

Jim DeMars
FPL

FPL APPROVED IT METERING EQUIPMENT ENCLOSURE LIST

VII: 16 of 18

Instrument Transformer (IT) Rated Units - Before Purchase, Please Contact your FPL Representative

NOTE: Instrument Transformer Metering must be approved by FPL.

WALL MOUNTED TRANSFORMER CABINETS

MANF.	CATALOG NUMBER	STYLE & MATERIAL	PHASE	MAX # OF CONDUITS (Total # In and Out)	MAX # * AND SIZE OF CONDUCTORS	APPROX SIZE (H" x W" x D")	CONFIG
Austin Co.	FPL-S-TC3	TC-3 Alum	1,3	4 - 4"	8 - 600C or 8 - 400A	34 x 32 x 10	7
	FPL-S-TC3-GRAY	TC-3 Galv	1,3	4 - 4"	8 - 600C or 8 - 400A	34 x 32 x 10	7
	FPL-S-TC3 SS	TC-3 SS	1,3	4 - 4"	8 - 600C or 8 - 400A	34 x 32 x 10	7
	FPL-S-TC5	TC-5X Alum	3	8 - 4"	16-600C or 16-400A	46 x 30 x 14.5	8
	FPL-S-TC5-GRAY	TC-5X Galv	3	8 - 4"	16-600C or 16-400A	46 x 30 x 14.5	8
	FPL-S-TC5 SS	TC-5X SS	3	8 - 4"	16-600C or 16-400A	46 x 30 x 14.5	8
	FPL-C-TC1	Custom Alum	3	As Req.	As Required	As Required	9
	FPL-C-TC1-SS	Custom Stainless	3	As Req.	As Required	As Required	9
	FPL-C-TC1-GRAY	Custom Steel	3	As Req.	As Required	As Required	9
C&I	C-343212FPLA-TC3	TC-3 Alum	1,3	4 - 4"	8 - 600C or 8 - 400A	34 x 32 x 10	7
	C-343212FPLHG-TC3*	TC-3 Alum	1,3	4 - 4"	8 - 600C or 8 - 400A	34 x 32 x 10	7
	C-463014.50FPLA-TC5	TC-5 Alum	3	8 - 4"	16-600C or 16-400A	46 x 30 x 14.5	8
	C-463014.50FPLHG-TC5*	TC-5 Alum	3	8 - 4"	16-600C or 16-400A	46 x 30 x 14.5	8
	*HG – Hinged Cover						
Cooper/ B-Line	323410 RTCT1F AL	TC-3 Alum	1,3	4 - 4"	8 - 600C or 8 - 400A	34 x 32 x 10	7
	323410 RTCT1F	TC-3 Steel	1,3	4 - 4"	8 - 600C or 8 - 400A	34 x 32 x 10	7
	323412 RTCT1F AL	TC-3 Alum	1,3	4 - 4"	8 - 600C or 8 - 400A	34 x 32 x 12	7
	323412 RTCT1F	TC-3 Steel	1,3	4 - 4"	8 - 600C or 8 - 400A	34 x 32 x 12	7
	304614.5 RTCT1F AL	TC-5X Alum	3	8 - 4"	16-600C or 16-400A	46 x 30 x 14.5	8
	304614.5 RTCT1F	TC-5X Steel	3	8 - 4"	16-600C or 16-400A	46 x 30 x 14.5	8
EBox	A343212RB/FPLTC3	TC-3 Alum	1,3	4 - 4"	8 - 600C or 8 - 400A	34 x 32 x 12	7
	343212REPL/FPL*	TC-3 Steel	1,3	4 - 4"	8 - 600C or 8 - 400A	34 x 32 x 12	7
	* Left-hand hinged						
	343212REPL/RH/FPL	Right-hand hinged					
	A463014.50RB/FPLTC5	TC-5 Alum	3	8 - 4"	16 - 600C or 16 - 400A	46 x 30 x 14.5	8
	A463014.50REPL/FPL*	TC-5 Steel	3	8 - 4"	16 - 600C or 16 - 400A	46 x 30 x 14.5	8
	* Left-hand hinged						
	463014.50REPLRH/FPL Right-hand hinged						
Hoffman	TC3AL	TC-3 Alum	1,3	4 - 4"	8 - 600C or 8 - 400A	34 x 32 x 10	7
	TC3SS	TC-3 Stainless	1,3	4 - 4"	8 - 600C or 8 - 400A	34 x 32 x 10	7
	TC3	TC-3 Steel	1,3	4 - 4"	8 - 600C or 8 - 400A	34 x 32 x 10	7
	TC5AL	TC-5 Alum	3	8 - 4"	16-600C or 16-400A	46 x 30 x 14-1/2	8
	TC5SS	TC-5 Stainless	3	8 - 4"	16-600C or 16-400A	46 x 30 x 14-1/2	8
	TC5	TC-5 Steel	3	8 - 4"	16-600C or 16-400A	46 x 30 x 14-1/2	8

PREPARED BY

SUBJECT

SECTION:PAGE

Jim DeMars
FPL

FPL APPROVED IT METERING EQUIPMENT ENCLOSURE LIST

VII: 17 of 18

Instrument Transformer (IT) Rated Units - Before Purchase, Please Contact your FPL Representative

NOTE: Instrument Transformer Metering must be approved by FPL.

MANF.	CATALOG NUMBER	STYLE & MATERIAL	PHASE	MAX # OF CONDUITS (Total # In and Out)	MAX # * AND SIZE OF CONDUCTORS	APPROX SIZE (H" x W" x D")	CONFIG
	TC5XAL	TC-5X Alum	3	As Req.	As Required	46 x 30 x 16	9
	TC5XSS	TC-5X Stainless	3	As Req.	As Required	46 x 30 x 16	9
	TC5X	TC-5X Steel	3	As Req.	As Required	46 x 30 x 16	9
Meter Devices Co.	561U3801	TC-3 Alum	1,3	4 - 4"	8 - 600C or 8 - 400A	34 x 32 x 10	7
	561U3815G	TC-3 Alum	1,3	4 - 4"	8 - 600C or 8 - 400A	34 x 32 x 12	7
	561U3802	TC-5X Alum	3	8 - 4"	16-600C or 16-400A	46 x 30 x 14.5	8
Milbank	323412-SC3RA-SP	TC-3 Alum	1,3	4 - 4"	8 - 600C or 8 - 400A	28 x 30 x 12	7
	304614-SC3RA-SP	TC-5 Alum	1,3	4 - 4"	16-600C or 16-400A	46 x 30 x 14.5	8

FPL will no longer accept Steel or Stainless TC-3 and TC-5 Cabinets with pull-off covers. Only Aluminum pull-off covers are allowed. All Steel and Stainless TC-3 and TC-5 Cabinets must have hinged doors. Contact Meter Engineering for correct part number and approval.

*Max Number of Conductors is the TOTAL number of conductors ENTERING the cabinet plus the number EXITING the cabinet.

WEATHERHEAD MOUNTED TRANSFORMER CABINETS

MANUFACTURER	CATALOG NUMBER	STYLE & MATERIAL	PHASE	APPROX SIZE (H" X W" X D")	CONFIGURATION
Meter Devices Co.	558-5127**	TCWM Alum	1,3	27-1/2 x 6-1/2 x 6-1/2	10
	508-5127**	TCWM Steel	1,3	27-1/2 x 6-1/2 x 6-1/2	10

Note: These cabinets are **not UL Listed and may not be utilized in jurisdictions where listing is a requirement.

PRIMARY PADMOUNTED TRANSFORMER CABINETS

MANUFACTURER	CATALOG NUMBER	MATERIAL	PHASE	VOLTAGE	MAX AMPS	APPROX SIZE (H" x W" x D")	CONFIG
Meter Devices	SKA270192-1AL	Aluminum	3	25kV	1 x 200	54 x 72 x 54	11
Shallbetter	SPMD-32522-22-SS-FPL	Stainless Steel	3	25 kV	2 x 200	54 x 72 x 72	11
	SPMD-32522-66-SS-FPL	Stainless Steel	3	25 kV	2 x 600	54 x 72 x 72	11
	SPMD-32522-22-AL-FPL	Aluminum	3	25 kV	2 x 200	54 x 72 x 72	11
	SPMD-32522-66-AL-FPL	Aluminum	3	25 kV	2 x 600	54 x 72 x 72	11
SPS	DFPM -3252266-SS-FPL	Stainless Steel	3	25 kV	2 x 200	54 x 72 x 72	11
	DFPM -3252222-SS-FPL	Stainless Steel	3	25 kV	2 x 600	54 x 72 x 72	11
	DFPM -3252266-AL-FPL	Aluminum	3	25 kV	2 x 200	54 x 72 x 72	11
	DFPM -3252222-AL-FPL	Aluminum	3	25 kV	2 x 600	54 x 72 x 72	11

Instrument Transformer (IT) Rated Units - Before Purchase, Please Contact your FPL Representative

NOTE: Instrument Transformer Metering must be approved by FPL.

PREPARED BY		SUBJECT		REVISED
Jim DeMars FPL		FPL APPROVED IT METERING EQUIPMENT ENCLOSURE LIST		07-01-11 SECTION:PAGE
				VII: 18 of 18

Instrument Transformer (IT) Rated Units - Before Purchase, Please Contact your FPL Representative
NOTE: Instrument Transformer Metering must be approved by FPL.

METERING EQUIPMENT CABINETS

MANUFACTURER	CATALOG NUMBER	STYLE & MATERIAL	USEAGE	TYPE	APPROX SIZE (H" x W" x D")	CONFIG	
Austin Co.	FPL-EE-M	SJB-28 Alum	UTILITY	MED	28 x 30 x 14	12	
	FPL-EE-M-SS	SJB-28 Stainless	UTILITY	MED	28 x 30 x 14	12	
	FPL-EE-M-GRAY	SJB-28 Steel	UTILITY	MED	28 x 30 x 14	12	
	FPL-EE-L	SJB-C Alum	UTILITY	LARGE	36 x 36 x 14	12	
	FPL-EE-L-SS	SJB-C Stainless	UTILITY	LARGE	36 x 36 x 14	12	
	FPL-EE-L-GRAY	SJB-C Steel	UTILITY	LARGE	36 x 36 x 14	12	
	FPL-EE-X	SJB-CX Alum	UTILITY	X-LARGE	46 x 36 x 14	12	
	FPL-EE-X-SS	SJB-CX Stainless	UTILITY	X-LARGE	46 x 36 x 14	12	
	FPL-EE-X-GRAY	SJB-CX Steel	UTILITY	X-LARGE	46 x 36 x 14	12	
	FPL-UTB-A	UTB Alum	UTILITY	-	12 x 8 x 3-3/4	12	
	FPL-UTB-A-SS	UTB Stainless	UTILITY	-	12 x 8 x 3-3/4	12	
	FPL-UTB-A-GRAY	UTB Steel	UTILITY	-	12 x 8 x 3-3/4	12	
	Meter Devices Co.	557U3807 or 574U3807	SJB-28 Alum		MED	30 x 28 x 14	12
		507U3807 or 524U3807	SJB-28 Steel		MED	30 x 28 x 14	12
		557U3805 or 574U3805	SJB-C Alum		LARGE	36 x 36 x 14	12
507U3805 or 524U3805		SJB-C Steel		LARGE	36 x 36 x 14	12	
557U3806 or 574U3806		SJB-CS Alum		X-LARGE	46 x 36 x 14	12	
507U3806 or 524U3806		SJB-CS Steel		X-LARGE	46 x 36 x 14	12	
561U3811		UTB Alum	UTILITY	-	12 x 8 x 3-3/4	12	
511U3811		UTB Steel	UTILITY	-	12 x 8 x 3-3/4	12	
566U5183-FPL		UMC	UTILITY	-	20 x 16 x 6	13	
Milbank		302814-CT3RA-SP	SJB-28 Alum	UTILITY	MED	30 x 28 x 14	12
	302814-CT3RS-SP	SJB-28 Stainless	UTILITY	MED	30 x 28 x 14	12	
	302814-CT3R-SP	SJB-28 Steel	UTILITY	MED	30 x 28 x 14	12	
	363614-CT3RA-SP	SJB-C Alum	UTILITY	LARGE	36 x 36 x 14	12	
	363614-CT3RS-SP	SJB-C Stainless	UTILITY	LARGE	36 x 36 x 14	12	
	363614-CT3R-SP	SJB-C Steel	UTILITY	LARGE	36 x 36 x 14	12	

Instrument Transformer (IT) Rated Units - Before Purchase, Please Contact your FPL Representative
NOTE: Instrument Transformer Metering must be approved by FPL.



Electric Service Standards

DATE

01-02-04

PREPARED BY

Distribution Construction Processes

SUBJECT

VIII. GROUNDING

SECTION: PAGE

VIII: 1 of 2

VIII. GROUNDING

A. General

The Customer's service entrance installation shall satisfy all grounding requirements of the National Electrical Code (NEC) and any applicable building codes, and is subject to acceptance of local inspecting authorities.

FPL's service drop or service lateral includes a grounded conductor. This conductor is grounded at the source transformer location and generally interconnected with other grounded conductors. This grounded conductor will normally be attached to a grounding connector in the meter socket and also to one in the service equipment and to the neutral or ground bus in the service equipment. When meter sockets with Customer owned isolated neutrals are required by local codes, a separate Customer owned grounding conductor shall be run by the Customer from the service equipment to the grounding connection of the meter socket.

The NEC allows several methods of supplying a grounding electrode. A ground rod is not the only means of supplying the grounding electrode. A brief discussion of the NEC requirements is provided in the following notes and is not intended to be all-inclusive. The NEC and your local inspecting authorities should be consulted for additional details and for those that may have changed since the time of this printing. FPL accepts any method which satisfies the NEC and the local inspecting authorities.

Local inspecting authorities may have more stringent requirements than the NEC. For example, some inspecting authorities require the use of a concrete-encased electrode as described in Section 250. This electrode would consist of at least 20 feet of one or more bare or zinc galvanized or other electrically conductive coated steel reinforcing bars or rods of not less than 1/2 inch in diameter or of at least 20 feet of bare copper conductor not smaller than No. 4. The electrode would be encased in at least 2 inches of concrete and located within or near the bottom of a concrete foundation or footing that is in direct contact with the earth.

B. Notes on Grounding Customer's Service Entrance:

1. FPL's point of delivery includes a grounded conductor. The point of delivery is normally at the weatherhead (in the case of an FPL overhead service lateral), the meter can (in the case of an FPL underground service lateral), a padmounted transformer or a vault.
2. The customer shall connect this FPL grounded conductor to the service equipment by extending a customer-owned grounded conductor along with the other conductors of the customer's service entrance which attach to FPL at the point of delivery. This grounded conductor shall be extended even though it may not be required as a circuit conductor by the NEC and shall be sized according to NEC 250.
3. The customer's service entrance wiring shall be grounded as required by the NEC, Article 250, and any local code in effect.
4. The grounded wiring system to each premise shall have a grounding electrode conductor connected to a grounding electrode meeting the requirements of the NEC. This grounded conductor shall be connected to the grounded service conductor at any accessible point on the load side of the service drop or lateral to and including the service equipment terminals provided to connect the grounded service conductor.



Electric Service Standards

DATE
01-02-04

PREPARED BY
Distribution Construction Processes

SUBJECT
VIII. GROUNDING

SECTION: PAGE
VIII: 2 of 2

5. The equipment grounding conductor and the service equipment enclosure shall be connected to the grounded conductor of the system within the service equipment or within the service conductor enclosure.
6. The grounding electrode system is discussed in section 250 of the NEC. Section 250 states that, if available on the premises, each of the following along with any "made" electrodes shall be bonded together to form the grounding electrode system, (a) metal underground water pipe, (b) metal frame of building, (c) concrete encased electrode, and (d) ground ring. The metallic water pipe shall be supplemented by an additional electrode of type specified in Section 250. The "made" electrode of Section 250 may be a local metal underground system or structure other than gas piping systems, a rod or pipe electrode, or a plate electrode. The rod or pipe electrode may be a listed 1/2" x 8' stainless steel or nonferrous rod, a 5/8" x 8' steel or iron rod, or a 3/4" x 8' galvanized pipe, all driven 8' into the earth. A plate electrode shall expose not less than two square feet of surface to exterior soil. Iron or steel plates shall be at least 1/4 inch thick and nonferrous plates shall be at least .06 inch thick. Aluminum "made" electrodes ARE NOT PERMITTED. A metal underground gas piping system SHALL NOT BE USED AS A GROUNDING ELECTRODE.
7. For additional grounding information, see the National Electrical Code, Article 250, and local building codes in effect in the area. If local building code requirements exceed those of the National Electrical Code, installations shall comply with the local codes.



Electric Service Standards

DATE
02-02-12

PREPARED BY

**Delivery Assurance –
Design Support**

SUBJECT

**IX. MOTORS, CONTROLLERS and AIR
CONDITIONERS**

SECTION: PAGE

IX: 1 of 5

IX. MOTORS, CONTROLLERS AND AIR CONDITIONERS

A. General

Before ordering or installing any large polyphase or single phase motor, FPL should be consulted to determine the character and adequacy of the available service and the allowable starting current at the premises to be served. This information should be passed on to the suppliers of the proposed motorized equipment. This will assist suppliers in providing equipment and protective devices to obtain satisfactory operation at minimum cost, considering both initial installation and future maintenance.

Motors less than 7.5 horse power can be served with single phase service, unless three phase service is already being supplied. Motors 7.5 to 20 horsepower require open delta service (or wye if already being supplied), and motors larger than 20 horsepower require wye service. Availability of three phase service should be discussed in advance with FPL.

Single phase motors larger than one-half horsepower fed from 120/240 volt circuits should be connected for 240 volt operation. Smaller motors may be connected for 240 volts, where practicable, at the Customer's option.

The current required to start a motor is much greater than that required to operate it at full load after it has reached rated speed. If not controlled, this starting current may cause severe voltage fluctuations, not only on the wiring of the Customer using the motor, but also on other Customers' wiring. The more frequently the motor is started, the more objectionable these voltage fluctuations become.

The National Electrical Code, in Article 430, provides a table (430.7(B)) which classifies motors by their "locked-rotor" (starting) input requirements. A code letter is assigned to each requirement bracket. The brackets are given in "kilovolt-amperes" per horsepower which can be easily converted to amperes for a given motor. The starting current increases as the code letter increases. The appropriate letter is stamped on the motor nameplate.

Using this information, FPL has prepared **Table IX-1** for single phase motors, five horsepower and below. This table lists code letters and starting currents which will be acceptable at most locations on FPL's system. The value given is for one motor which does not start more than four times per hour. **Table IX-2** provides similar data for single phase air conditioners, but is based on the unit's rated output rather than horsepower.

B. FPL Approval of Starting Means for Large Motors

For motors larger than those listed in **Table IX-1**, or which start more frequently, the Customer may be required to provide reduced voltage or incremental starting equipment, to reduce each step of starting current to the value shown. FPL shall be consulted and will advise the Customer of its requirements.

In the case of three phase motors, because of the variety of service conditions and the large number of motor sizes available, FPL shall be contacted in each case to determine if reduced voltage or incremental starting will be required. If two or more motors are started simultaneously, the starting limitations apply to the total current of the group.



Electric Service Standards

DATE
02-02-12

PREPARED BY
**Delivery Assurance –
Design Support**

SUBJECT
**IX. MOTORS, CONTROLLERS and AIR
CONDITIONERS**

SECTION: PAGE
IX: 2 of 4

Table IX-1

**Single Phase Motors Acceptable for Across the Line
Starting at Most Locations on FPL System
Horsepower Ratings by NEC Letters
No more than Four Starts Per Hour**

ACCEPTABLE CODE LETTERS

HORSEPOWER	115 VOLTS(50 AMPS)	230 VOLTS	MAXIMUM STEP IN STARTING CURRENT
1/4	A THRU V	A THRU V	50 AMPS
1/3	A THRU S	A THRU V	50 AMPS
1/2	A THRU N	A THRU V	50 AMPS
3/4	A THRU J*	A THRU S	50 AMPS
1	A THRU G*	A THRU P	50 AMPS
1 1/2	A THRU C*	A THRU K	50 AMPS
2		A THRU H	60 AMPS
3		A THRU G	80 AMPS
5		A THRU F	120 AMPS

*These motors should be connected for 230 volt operation if feasible.

TABLE IX-2

Acceptable Air Conditioning Equipment, One Phase, 240 Volts

SIZE IN TONS (NOTE 1)	SIZE IN BTU	*MAXIMUM ALLOWABLE STEP IN STARTING CURRENT AT 240V
1	12,000	40 AMPS
1 1/2	18,000	60 AMPS
2	24,000	80 AMPS
3	36,000	120 AMPS
4	48,000	160 AMPS
5 (NOTE 2)	60,000	200 AMPS

Note 1: Table based on units being sized and maintained so that there will be a maximum of four starts per hour.

Note 2: Better performance may sometimes be obtained by using two smaller units.

* This is the maximum allowed coincident starting current of any, or all of the system's components (compressor, condenser fan motor, and air handler blower motor). If the System Starting Current exceeds the values shown, the customer should investigate the installation of either a "hard start" kit or "stage" starting (or other method recommended by the manufacturer) to reduce the starting current to the level for which FPL's distribution system was designed.



Electric Service Standards

DATE
02-02-12

PREPARED BY

Delivery Assurance –
Design Support

SUBJECT

IX. MOTORS, CONTROLLERS and AIR
CONDITIONERS

SECTION: PAGE

IX: 3 of 5

C. Motor Protection and Power Factor

It is the customer's responsibility to ensure that all motor circuits include protection which at a minimum meets the National Electrical Code and any applicable local codes. Note: such protection is designed to protect personnel from electrical and fire hazard, it is not intended to protect the motor from damage. For this reason, FPL recommends that the customer add the following to motor circuits to reduce the risk of equipment damage.

The use of automatic time delay circuit breakers or time delay fuses is strongly recommended when protecting motors against damage from excessive currents. The time delay feature will eliminate unnecessary operation of the breakers or blowing of fuses during motor starting or temporary overloads.

AURORA Protection - "AURORA" is the term given to a type of attack (typically cyber but can also be manual) in which there is a deliberate and fast (5 to 15 cycles) turning off and on of the electrical power, multiple times. The primary focus of potential offenders is to damage electrical apparatus such as generators, motors, and transformers but, it can also damage breakers, conductors and adjustable frequency drives. Motors which cannot be safely subjected to full voltage starting, or processes which may create a safety hazard upon an uncontrolled re-start, should be designed to require manual or time delay re-start upon the interruption of the supply voltage.

Under Voltage Protection - A low-voltage release is designed to disconnect the motor automatically and return the starting device to the "off" position upon partial or total failure of the supply voltage. It is used, where applicable, for motors that cannot safely be subjected to full voltage at starting, or where low voltage would result in injury or damage to equipment. This release should be of the time delay type, capable of adjustment to a maximum of at least two seconds and set at the lowest value suitable for proper protection. FPL will be glad to advise the Customer on the proper interval for coordination with FPL's circuit breakers. This will prevent unnecessary disconnection of the motor on momentary voltage fluctuations or loss of voltage.

Single Phase Protection - When installing three phase motors, the Customer should consider the possibility of the loss of one phase, either in his own installation or in FPL's supply lines. This "single phasing" may happen regardless of the precautions taken to avoid it, and FPL therefore strongly recommends that devices be installed to protect the equipment against the damage that may result.

Phase Reversal Protection - Three phase motors for applications to elevators, cranes, hoists, well pumps or other installations where reversal of rotation might cause damage to equipment or constitute a hazard to personnel **should have phase rotation protection.**

Phase Imbalance Protection – Imbalanced three phase voltages may cause unequal phase currents. Heating caused by the imbalanced currents can shorten the life of a motor. Because of this, the American National Standards Institute, ANSI C84.1-2006 Standard for Power Systems and Equipment, recommends that "electric supply systems be designed and operated to limit the maximum voltage imbalance to 3 percent when measured at the electric-utility revenue meter under no-load conditions".

ANSI uses the formula:

Percent Imbalance = Maximum deviation from the average divided by the average



Electric Service Standards

DATE
02-02-12

PREPARED BY
**Delivery Assurance –
Design Support**

SUBJECT
**IX. MOTORS, CONTROLLERS and AIR
CONDITIONERS**

SECTION: PAGE
IX: 4 of 4

To protect motors from damage due to amperage imbalance, imbalance protection should be installed at the motor to limit full load operation if the voltage imbalance exceeds 3%, or the amperage imbalance exceeds 30%.

Note: Some brands of protection on the market for chillers and other motors use the formula:

Percent Imbalance = (Highest phase – lowest phase) divided by the average

Devices using this formula should be set at 4% voltage and 40% amperage to provide the same protection as the ANSI formula.

Under voltage, single phase, phase reversal and imbalance protection are all available through the installation of an electronic phase loss protector in the motor control circuit. Such protective devices are supplied and installed by the Customer. FPL is not responsible for damage to motors from power abnormalities.

Surge protection should also be considered for installation at the motor breaker panel. Surge protection can help reduce damage to a motor's windings from external spikes, as well as reduce damage to customer equipment from power spikes generated by large motors starting and stopping.

Power Factor

Power factor is a calculation representing the relationship of "real" power (kw) which performs useful work in turning a motor, to "apparent" power (kva) which magnetizes motor and transformer coils. Motor loads frequently adversely affect the power factor of a circuit, usually from oversized or lightly loaded motors. Certain other types of loads can reduce power factor. A low power factor also reduces the capacity of circuit conductors to deliver "real" power and can increase wiring costs as well as electric demand on the utility system. FPL reserves the right to adjust meter reading kw for billing where power factor is less than 85%.

Capacitors are sometimes connected on the load side of a motor controller to improve the power factor of the circuit. When this is done, the total kvar connected should not exceed the value required to raise the power factor of the motor to unity when it is running unloaded.

D. Air Conditioners that require excessive starting currents

A number of single phase 240 volt air conditioning units currently on the market require starting currents that exceed the 40 amps per ton allowed by FPL design practices. This will cause voltage flicker (momentary voltage dips) to exceed the limits to which FPL's distribution systems have been designed, and in many cases, flicker conditions quite objectionable to homeowners having these units.

Air conditioning units causing the majority of complaints seem to be those with the "scroll" type compressor, that are 3 tons or greater. Unlike their predecessor reciprocating compressor types, these systems do not require a starting capacitor system to start, so the manufacturers are no longer installing them. Without starting capacitors, the starting currents drawn on the electrical distribution system and "seen" by the customer as flicker have increased dramatically.

We strongly suggest you verify, before purchasing, that the units you obtain require starting currents of 40 amps or less per ton. If these limits are exceeded, "hard start kits" should be installed. If further reductions are necessary, "delay start" mechanisms might be considered so all the units components (compressor, air handler, condensing fan) do not start simultaneously. Installing this equipment at the factory can be done for minimal cost (far less than retrofits in



Electric Service Standards

DATE

02-02-12

PREPARED BY

**Delivery Assurance –
Design Support**

SUBJECT

**IX. MOTORS, CONTROLLERS and AIR
CONDITIONERS**

SECTION: PAGE

IX: 5 of 5

the field) and will prevent customer complaints. If FPL has to oversize new facilities or upgrade existing facilities due to starting currents exceeding the 40 amp per ton threshold, CIAC charges would apply.

Air conditioning manufacturers do not routinely publish starting current values. For units without starting capacitors a “rough” approximation of the starting current can be obtained by adding the Locked Rotor Amp (LRA) values for the compressor, condenser fan and air handler, and multiplying this total by 1.10. For further information on this subject contact your local FPL construction representative.



Electric Service Standards

DATE
07-11-07

PREPARED BY

SUBJECT

SECTION: PAGE

Distribution Construction Processes

X. ELECTRICAL DISTURBANCES

X: 1 of 1

X. ELECTRICAL DISTURBANCES

Electric welders, furnaces, electric draglines, electric dredges, large, frequently started, motorized equipment, variable speed drives, SCR converters, and tankless water heaters are **examples** of equipment that have operating characteristics which may require rapidly fluctuating amounts of current. If the device is large, significant voltage fluctuations may result, even on a system which is adequate for normal service. ***These voltage fluctuations may affect the operation and life of other equipment in the customer's facility as well as the equipment of other customers in the vicinity.***

Section IX covers FPL's requirements when frequent starting of large motors is involved.

When service is required for any of the other devices mentioned, or similar devices, FPL shall be consulted. It may be found that the device cannot be served at the specific location unless special facilities and control equipment are provided both by FPL and the Customer.

The cost for any additional or upgraded facilities that are required to be installed by FPL in order to serve these devices will be borne by the customer as CIAC. If the adverse effects cannot be mitigated by the installation of additional or upgraded facilities, or if these devices cause objectionable flicker to other customers' service, FPL may require the device to be disconnected from the electrical system.

There are other devices, such as silicon controlled rectifier (SCR) devices, or any device which suddenly interrupts current at other than a natural zero point, which may cause high frequency voltage oscillations or transients in the circuit. This may be detrimental to the Customer's service or to that of an adjacent Customer. It may be necessary for the Customer to install filters or other corrective devices if he wishes to continue the use of such equipment.

If the Customer uses carrier current or any other system that superimposes a voltage with a frequency other than the normal 60 hertz voltage on his wiring, he shall provide filters or other equipment, as required, to prevent it from appearing on FPL's distribution system.



FPL

Electric Service Standards

DATE

01-02-04

PREPARED BY

Distribution Construction Processes

SUBJECT

XI. RADIO, TELEVISION AND MISCELLANEOUS ANTENNAS

SECTION: PAGE

XI: 1 of 1

XI. RADIO, TELEVISION AND MISCELLANEOUS ANTENNAS

Radio and television antennas, their lead-in cables, guy wires and metallic supports shall be kept well clear of electric powerlines. They should be installed in accordance with Article 810 of the National Electrical Code, and any applicable local building code.

The shortest distance between the power conductor and the antenna mast should exceed the height of the antenna mast from the ground.

The antenna or lead in conductors should not cross over electric light or power circuits. These items should be kept well away from such circuits, but where this is impossible, they shall have a clearance of at least 2 feet to circuits of less than 250 volts between conductors. Where practicable, these items should not cross under electric light and power circuits or be closer than 10 feet to power circuits of more than 250 volts between conductors.

Most contacts between antennas and power lines occur either during antenna installation or subsequent maintenance. The homeowner installing an antenna should be sure it is well away from any exposed electric wires. He should be certain that neither the antenna and mast nor the lead-in nor guy wires could possibly contact the power wires if the installer loses control of any component of the assembly.



Electric Service Standards

DATE
09-01-11

PREPARED BY

Distribution Construction Processes

SUBJECT

XII. STREET & OUTDOOR SECURITY LIGHTING

SECTION: PAGE

XII: 1 of 4

XII. STREET & OUTDOOR SECURITY LIGHTING

A. Street Lighting

Application - The application of FPL's Street Lighting Rate schedule (SL-1), as defined in FPL Tariff Sheet 8.715 is for the lighting of streets and roadways, whether public or private, which are thoroughfares for normal flow of vehicular traffic. Lighting for other applications such as: municipally and privately owned parking lots; parks and recreational areas; or any other area not expressly defined above, is not permitted under this schedule.

For Customer owned street lighting systems, where the street light facilities are installed, owned, and maintained by the Customer, FPL will specify the service location, connect to the customer's system, and provide energy and relamping services (if applicable) in accordance with rate schedule SL-1. Customer owned systems shall be of a standard type and design, permitting service and lamp replacement (if applicable) at no abnormal cost to FPL. The placement of customer owned streetlights on FPL poles is prohibited.

If FPL is requested to install, own, and maintain its street lighting facilities, service is subject to the terms and conditions of rate schedule SL-1 together with FPL's Street Lighting Agreement, which must be properly executed prior to the installation or modification of any FPL owned street lighting facility.

For FPL owned street lighting facilities, A CIAC will be required from the customer for:

a. the estimated differential cost between employing rapid construction techniques in trenching, backfilling, and pole installation work where no obstructions exist, and the added cost to overcome obstructions such as sprinkler systems, paved surfaces (such as sidewalks, curbs, gutters, and roadways), landscaping, sodding and other obstructions encountered along the Street Lighting System installation route, including repair and replacement. As an alternative to paying FPL for these added costs, the customer can elect to perform the trenching work and restoration himself. If that work involves trench (and installation of conduit provided by FPL), the Customer will be reimbursed by FPL for the value, as determined by FPL, of that trench (based on rapid construction, no obstructions) and conduit installation.

b. the installation cost of any new overhead distribution facilities and/or the cost of alterations to existing distribution facilities which are required in order to serve the Street Lighting System less four (4) times the additional annual non-fuel energy revenue generated by the installation or alteration of the Street Lighting System, plus where underground facilities are installed, the differential installation cost between underground and overhead distribution facilities.

These costs, if any, shall be paid by the Customer before the commencement of any construction work by FPL. The Customer shall also pay any additional costs associated with design modifications requested after the original estimate has been made. **FPL does not design to or guarantee minimum street lighting levels based on any IES standards.**

If FPL street lighting facilities must be removed for any reason (Customer request, relocation, upgrade, modification, termination or breach of the Agreement, etc.) the Customer shall pay FPL an amount equal to the original installed cost of the removed facilities less any salvage value and depreciation (based on current depreciation rates as approved by the Florida Public Service Commission) plus removal cost. In the event of relocated facilities, all relocation costs will be borne by the Customer.

If these terms and conditions are unacceptable to the Customer, or if the poles and fixtures offered by FPL are not those desired by the Customer, the Customer may wish to consider installing his own street lighting facilities.



B. Outdoor Security Lighting

Application - The application of FPL's Outdoor Lighting Rate schedule, as defined in FPL Tariff Sheet 8.725 is for year-round outdoor security lighting of yards, walkways, and other areas on property owned by individuals or organizations. This rate schedule is **not** available for Street Lighting applications (public or private roadway lighting). Lights to be served hereunder shall be at locations which are easily and economically accessible to FPL equipment and personnel for construction and maintenance.

It is intended that FPL-owned security lights be installed on existing FPL-owned facilities (distribution poles with secondary conductor), or "short extensions." Short extensions are limited to the installation of a single pole and span of secondary. There is no defined limit to the number of outdoor security lights available to one customer.

Where more extensive lighting systems are required, such as parking lots or other "engineered lighting level" applications where more than a single pole extension, or more than FPL lights installed on existing distribution facilities is required, the Customer can elect to provide the fixtures, supports & circuit wiring. FPL will specify the service location, connect to the customers system, and provide energy and relamping services, if applicable, in accordance with rate schedule OL-1.

If the Customer requests, or, if the energy provided through the Customer's metered service under a GS Rate is to the Customer's advantage, the service for the lighting can be provided under the appropriate GS rate schedule.

The number of OLs allowed is limited to four (4) lights per pole on those poles entirely devoted to the support of OLs, and two lights on all other poles. These limits are to be reduced wherever FPL engineering opinion or construction forces recommend.

Luminaires installed on poles along an adjacent roadway **must** be faced towards private property. The bracket length for conventional luminaires is 2-1/2 feet. Longer brackets will be considered only at locations accessible to FPL equipment and personnel.

Standard installations requiring installation of **only** outdoor lighting facilities covered by a monthly charge (e.g. luminaire, bracket, single span of secondary per light, pole, down guy, UG conductors, etc.) generally require no CIAC.

However, when installation or modification of distribution facilities is required for which there is no monthly charge (e.g. transformers, additional spans of secondary beyond the allowed single span per light, change in height of existing poles, installation of midspan poles, etc.) a CIAC will be required equal to the total estimated cost of those facilities not included in the schedule of monthly charges. EAR is **not** a factor in determining this CIAC amount.

For outdoor lighting applications requiring UG conductors, the customer **must** provide the trench, backfill, and restoration. If mutually agreed by the customer and FPL, FPL will provide the trench, but at the customer's expense.



Electric Service Standards

DATE
09-01-11

PREPARED BY

Distribution Construction Processes

SUBJECT

XII. STREET & OUTDOOR SECURITY LIGHTING

SECTION: PAGE

XII: 3 of 4

C. Disconnect Devices for Customer-Owned Street/Outdoor Security Lighting

When a customer-owned street/outdoor lighting circuit (a circuit being one or more lights served from one service point) is to be installed under the street/outdoor lighting rate schedules (SL-1, OL-1), the customer **shall** install a fused disconnect device for each circuit. Installation of the disconnect device **is required** whether the circuit is individual or group control. The disconnect device is required to isolate the customer's circuit during maintenance, isolate FPL's system from malfunctioning customer equipment, and comply with any applicable building code requirements.

Location of Customer's Disconnect Device:

Overhead FPL Service Point:

Customer disconnect device can be mounted on the customer's street/outdoor light pole provided that the distance to FPL's overhead service point allows for the provision of an FPL overhead service and that the attachment height allows for proper clearances.

Customer's disconnect device can be installed in customer handhole adjacent to the utility pole. FPL will terminate its underground cable (from the overhead source) in the customer handhole if this arrangement is acceptable to the customer. Otherwise, FPL will provide its own handhole at the base of the pole and terminate the customer's cable therein. In either case, a Contribution In Aid of Construction (CIAC) may be required.

Customer's disconnect device can be installed on a pedestal adjacent to the pole. FPL will extend its underground cable (from the overhead source) to its handhole adjacent to the utility pole and terminate the customer's cable therein. CIAC may be required. If sufficient attachment height is made available by the customer, FPL may provide an overhead service.

No customer equipment is to be installed on the utility-owned pole. Customer-owned secondary risers will be allowed only for those governmental agencies that have executed a Public Body Joint Use Pole Agreement.

Underground FPL Service Point:

Customer disconnect device shall be installed adjacent to FPL's service point on customer's pedestal or in customer's handhole. FPL will terminate the customer's cable at the service point.

Both the fusing and the cable from the FPL service point to customer's disconnect device shall be installed by the customer in accordance with applicable building codes.

Customer-owned disconnect devices are not to be installed to control FPL-owned street lighting facilities.

Group Control Photoelectric Relays

Overhead FPL Service Point:

The customer shall install, own, and maintain the photoelectric relay. For these installations, FPL will continue to provide transformation, as necessary, and connect the electric service as before. The remainder of the equipment (together with the photoelectric relay) will be installed and maintained by the customer, but cannot be installed on the utility pole.

This information and wiring diagram should appear on the preliminary streetlight plans for each project to allow FPL the opportunity to review and provide comments prior to final acceptance for each project.



Electric Service Standards

DATE
09-01-11

PREPARED BY

SUBJECT

SECTION: PAGE

**Distribution Construction
Processes**

XII. STREET & OUTDOOR SECURITY LIGHTING

XII: 4 of 4

Should the customer owned photoelectric relay fail for any reason, FPL asks the customer's cooperation in making timely repairs to avoid the 24 hour burning of street lights. Should timely repairs not be made, FPL may exercise its option of billing the maintaining agency for the increased energy consumption until the repairs are made.

Underground FPL Service Point:

The customer shall install, own, and maintain the photoelectric relay to group controlled customer owned streetlight circuits fed from handholes or padmounted transformers.

Should the customer owned photoelectric relay fail for any reason, FPL asks the customer's cooperation in making timely repairs to avoid the 24 hour burning of street lights. Should timely repairs not be made, FPL may exercise its option of billing the maintaining agency for the increased energy consumption until the repairs are made.



PREPARED BY

Distribution Construction Processes

SUBJECT

XIII. SAFETY

SECTION: PAGE

XIII: 1 of 5

XIII. Safety Six

According to the Bureau of Labor Statistics, workplace accidents kill more than 5,000 U.S. workers every year. We urge our customers and employees to practice safe work habits to prevent serious injuries and save lives! Always follow the Safety 6 rules to prevent the most common mistakes around power lines.

Rule 1: Work a safe distance

This is the most important rule: Work at a safe distance from all power lines. The Occupational Safety and Health Administration (OSHA) requires that equipment be kept at least 10 feet away from power lines from 0-50 kV. For higher voltage lines, the required distance is even greater (see table below). When uncertain of a power line's voltage, stay 20 feet away for voltages up 350 kV and 50 feet away for voltages greater than 350 kV. Cranes and derricks are required to take additional steps before beginning work (see OSHA Standards 29 CFR 1926.1400 effective Nov. 8, 2010). Call FPL at 1-800-375-4375 or your local utility to identify the voltage of power lines before you begin working.

If you witness a violation of the rules, stay away from the equipment and warn the operator to move away from the power line.

FPL Power Line Voltages	OSHA Mimimum Approach Distance (OSHA 1926.1408 Table A)
0 – 50 kV	10 feet
Over 50 kV to 200 kV	15 feet
Over 200 kV to 350 kV	20 feet
Over 350 kV to 500 kV	25 feet
Over 500 kV to 750 kV	35 feet

Rule 2: Stay calm - stay away

When operating a piece of equipment that contacts a power line	You should
You are <u>not</u> in danger from a fire or from being struck by a power line	<ul style="list-style-type: none"> Stay where you are. Move the equipment away from the power line, if possible. Warn others not to approach the equipment. Call FPL at 1-800-4OUTAGE (1-800-468-8243) or call 911 to contact FPL or your local utility for assistance.
You are in danger and must get off the equipment	<ul style="list-style-type: none"> Jump as far away from the equipment as you can and land with both feet together. (No part of your body should touch the equipment and the ground at the same time.) Hop or shuffle away from the equipment with your feet together to reduce the risk of electric shock. Once clear, do not return to the equipment until FPL declares it safe. Call 911 and/or call FPL at 1-800-4OUTAGE (1-800-468-8243) or your local utility.



PREPARED BY

SUBJECT

SECTION: PAGE

Distribution Construction Processes

XIII. SAFETY

XIII: 2 of 5

When operating a piece of equipment that contacts a power line	You should
If a fellow worker is in danger	<ul style="list-style-type: none"> • Stay away. • Warn fellow workers to stay away. • Call 911 and/or call FPL at 1-800-4OUTAGE (1-800-468-8243) or your local utility.

Rule 3: Ladders and lines don't mix

Before you begin working, look up and note the location of power lines. You can be seriously hurt or killed if the object you are holding or standing on contacts a power line.

- Before raising or extending any equipment capable of reaching a power line, check in all directions for power lines.
- Keep a safe distance from any power line, measuring from the end or tip of your own extended reach and including the end or tip of any object you are holding or carrying. Remember to allow even greater distance for safety near higher voltage lines such as transmission lines.
- Even nonmetallic ladders and equipment can conduct electricity.

Rule 4: Call before you dig

- One easy call to 811 starts the process of getting underground utility lines marked for free.
- Utility company locators will mark the approximate location and type of underground utilities with paint and flags.
- To avoid costly repairs and construction delays, be sure to contact Sunshine State One Call of Florida at 811 or 1-800-432-4770 at least two full business days in advance of any excavation work.* Visit www.CallSunshine.com for more information.

** In accordance with the Underground Facility Damage Prevention and Safety Act, Chapter 556, Florida Statutes*

Rule 5: Look up and live

Look up when working around overhead power lines, especially when trees are nearby. Branches can hide power lines from view.

- Look up for power lines when using tools of any kind. Even nonmetallic tools can conduct electricity.
- Cranes and derricks that approach working distance within 20 feet of power lines with operating voltages up to 350 kV, or within 50 feet of power lines with voltages greater than 350 kV, are mandated to take "encroachment prevention measures." See OSHA Standards 29 CFR 1926.1400.
- Look up for power lines when putting up scaffolding, framing a building, painting, pruning trees or picking fruit.
- Before moving a tree under a power line, look up and determine the maximum height to lift the tree. Keep a safe distance away as required by OSHA. Trees can conduct electricity.
- Look up for power lines when working on top of buildings.



FPL

Electric Service Standards

DATE

01-09-12

PREPARED BY

Distribution Construction Processes

SUBJECT

XIII. SAFETY

SECTION: PAGE

XIII: 3 of 5

- Before transporting large boats or large objects, please identify a safe route that avoids power lines. If you cannot avoid power lines, please call 1-800-375-4375 to coordinate transport and temporary removal* or de-energizing of FPL power lines.

** Charges may apply for temporary removal or relocation of power lines. You may need to coordinate transportation of oversized objects with local authorities.*

Rule 6: Downed lines can be deadly

Always assume that any downed power line is energized, and stay away.

- Do not touch or attempt to move any power line.
- Call 911 and 1-800-4OUTAGE (1-800-468-8243) or your local utility immediately.
- If a fellow worker touches a downed line or is handling equipment that contacts a power line, remember that any rescue attempt places you in danger.
- If you must rescue a person in contact with a power line, never use your hands. Use a dry, nonconductive object to move the person to safety.

Important contact information

Call 911 for any emergency.

**Call 1-800-4OUTAGE
(1-800-468-8243)**

to report contact with power lines,
downed power lines or an outage.

Call 811 before you dig.

Call 1-800-375-4375 for identification of
power line voltage or help with safe
transportation of large boats or large objects.



Electric Service Standards

DATE

01-09-12

PREPARED BY

SUBJECT

SECTION: PAGE

Distribution Construction Processes

XIII. SAFETY

XIII: 4 of 5

NOTIFICATION OF FPL FACILITIES

Customer/Agency _____ Date of Meeting/Contact: _____
 Developer/Contractor Name _____ Project Number/Name: _____
 Location of Project _____ City: _____
 FPL Representative _____ Phone: _____
 Developer/Contractor Representative _____ FPL Work Request #/Work Order #: _____

FPL calls your attention to the fact that there may be energized, high voltage electric lines, both overhead and underground, located in the area of this project. It is imperative that you visually survey the area and that you also take the necessary steps to identify all overhead and underground facilities prior to commencing construction to determine whether the construction of any proposed improvements will bring any person, tool, machinery, equipment or object closer to FPL's power lines than the OSHA-prescribed limits. If it will, you must either re-design your project to allow it to be built safely given the pre-existing power line location, or make arrangements with FPL to either deenergize and ground our facilities, or relocate them, possibly at your expense. **You must do this before allowing any construction near the power lines.** It is impossible for FPL to know or predict whether or not the contractors or subcontractors, and their employees, will operate or use cranes, digging apparatus or other mobile equipment, or handle materials or tools, in dangerous proximity to such power lines during the course of construction, and, if so, when and where. Therefore, if it becomes necessary for any contractor or subcontractor, or their employees, to operate or handle cranes, digging apparatus, draglines, mobile equipment, or any other equipment, tools or materials in such a manner that they might come closer to underground or overhead power lines than is permitted by local, state or federal regulations, you and any such contractor or subcontractor must notify FPL in writing of such planned operation prior to the commencement thereof and make all necessary arrangements with FPL in order to carry out the work in a safe manner. **Any work in the vicinity of the electric lines should be suspended until these arrangements are finalized and implemented.**

The National Electrical Safety Code ("NESC") prescribes minimum clearances that must be maintained. If you build your structure so that those clearances cannot be maintained, you may be required to compensate FPL for the relocation of our facilities to comply with those clearances. As such, you should contact FPL prior to commencing construction near pre-existing underground or overhead power lines to make sure that your proposed improvement does not impinge upon the NESC clearances.

It is your responsibility and the responsibility of your contractors and subcontractors on this project to diligently fulfill the following obligations:

1. Make absolutely certain that all persons responsible for operating or handling cranes, digging apparatus, draglines, mobile equipment or any equipment, tool, or material capable of contacting a power line, are in compliance with all applicable state and federal regulations, including but not limited to U.S. Department of Labor OSHA Regulations, while performing their work.
2. Make sure that all cranes, digging apparatus, draglines, mobile equipment, and all other equipment or materials capable of contacting a power line have attached to them any warning signs required by U.S. Department of Labor OSHA Regulations.
3. Post and maintain proper warning signs and advise all employees, new and old alike, of their obligation to keep themselves, their tools, materials and equipment away from power lines per the following OSHA minimum approach distances (refer to OSHA regulations for restrictions):

<u>*Power Line Voltages</u>	<u>**Personnel and Equipment</u> (29 CFR 1910.333 and 1926.600)	<u>Cranes and Derricks</u> (29 CFR 1926.1407, 1408)	<u>Travel under or near Power Lines (on construction sites, no load)</u>	
			<u>(29 CFR 1926.600 – Equipment)</u>	<u>(1926.1411 – Cranes and Derricks)</u>
0 - 750 volts	10 Feet	10 Feet	4 Feet	4 Feet
751 - 50,000 volts	10 Feet	10 Feet	4 Feet	6 Feet
69,000 volts	11 Feet	15 Feet	10 Feet	10 Feet
115,000 volts	13 Feet	15 Feet	10 Feet	10 Feet
138,000 volts	13 Feet	15 Feet	10 Feet	10 Feet
230,000 volts	16 Feet	20 Feet	10 Feet	10 Feet
500,000 volts	25 Feet	25 Feet	16 Feet	16 Feet

***When uncertain of the voltage, maintain a distance of 20 feet for voltages up to 350,000 volts and 50 feet for voltages greater than 350,000 volts.**

****For personnel approaching insulated secondary conductors less than 750 volts, avoid contact (Maintain 10 Feet to bare energized conductors less than 750 volts). For qualified personnel and insulated aerial lift equipment meeting requirements of 29 CFR 1910.333, distances may be reduced to those shown in 29 CFR 1910.333 Table S-5.**

4. All excavators are required to contact the Sunshine State One Call of Florida, phone number 1-800-432-4770 or 811 a minimum of two working days (excluding weekends) in advance of commencement of excavation to ensure facilities are located accurately.
5. Conduct all locations and excavations in accordance with the Florida Statute 556 of the Underground Facilities Damage Prevention & Safety Act and all local city and county ordinances that may apply.
6. When an excavation is to take place within a tolerance zone, an excavator shall use increased caution to protect underground facilities. The protection requires hand digging, pot holing, soft digging, vacuum methods, or similar procedures to identify underground facilities.

A copy of this notification must be provided by you to each contractor and subcontractor on this project, to be shared with their supervision and employees prior to commencing work on this project.

Means by which this notification was provided to customer and/or contractor

Address

FPL Representative Signature

Date

Customer/Developer/Contractor Representative Signature

Date









FIGURE XIII - 3

XIII. UNDERGROUND UTILITY LOCATING INFORMATION

CALL 2 BUSINESS DAYS BEFORE YOU DIG, IT'S THE LAW, CALL SUNSHINE 1-800-432-4770 (or simply dial 811)

Or visit www.callsunshine.com

- A. Information needed when you call:
 - Company Name & Address
 - Contact Person's Name
 - Phone Number
 - Call-Back Hours
- B. Dig site location information:
 - County & City
 - Location Address (or from where to where)
 - Nearest Cross Street
- C. Other:
 - Machinery to be Used
 - Permit Needed
 - Work Done For
 - Type of Work
- D. Color Codes for Marking Underground Utility Lines:

	ELECTRIC
	GAS - OIL - STEAM
	COMMUNICATION CATV
	WATER
	SEWER
	TEMPORARY SURVEY MARKINGS
	PROPOSED EXCAVATION